



**NANYANG
TECHNOLOGICAL
UNIVERSITY**

School of Mechanical & Aerospace Engineering

Design, Machine, Control, Intelligence



MA4822

Measurement and Sensing Systems

Xie Ming, PhD (France)

mmxie@ntu.edu.sg

<http://personal.ntu.edu.sg/mmxie>

Outline

- ▶ Module 1: Foundation of AI Sensors
- ▶ Module 2: Sensors for Electrical Systems
- ▶ Module 3: Sensors for Mechanical Systems
- ▶ Module 4: Sensors for All Environments
- ▶ Module 5: Sensors for All Industries

Remember your mission as MAE undergraduates ...

- ▶ You are here to grow your knowledge and skills so as to be able to design machines with **controllable behaviors** and hopefully in some **intelligent ways**.

How to fulfill your mission?

- ▶ To apply learnt knowledge and skills into the implementation of the following universal blueprint underlying all the intelligent machines or systems.

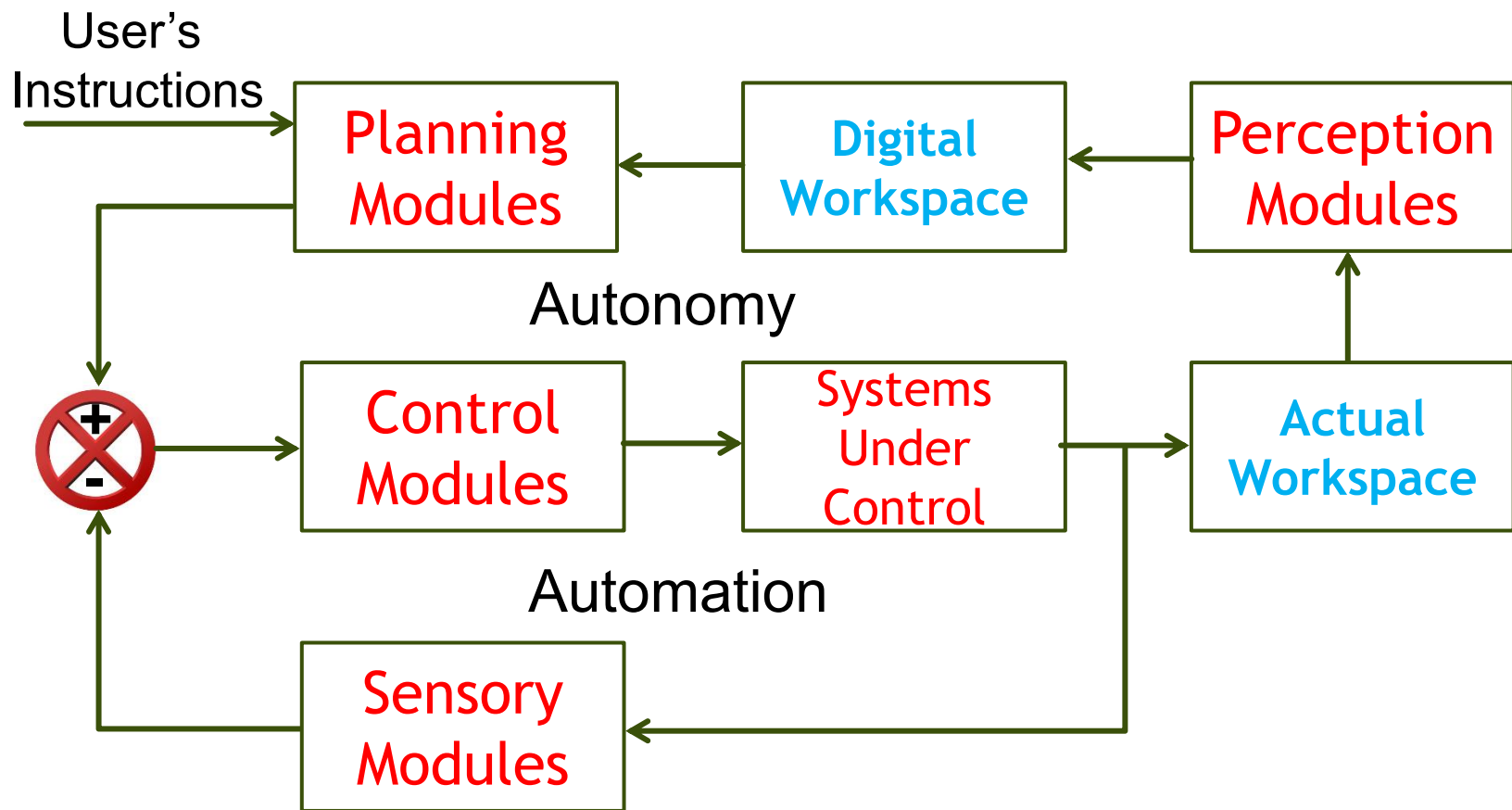

Why to study this course?



We are living inside an ocean of signals

(Learning, Teaching) <o> (Research, Innovation) <o> (Leadership, Service)

How to study this course?

- ▶ To put yourselves into the mindset of designers of networked sensors as products:
 - ▶ Who are the users?
 - ▶ What are the needs of users?
 - ▶ What are your Internet of Sensors, which could meet the needs of your users or buyers?
 - ▶ What are the solutions behind the design of your Internet of Sensors?

Practice with MATLAB

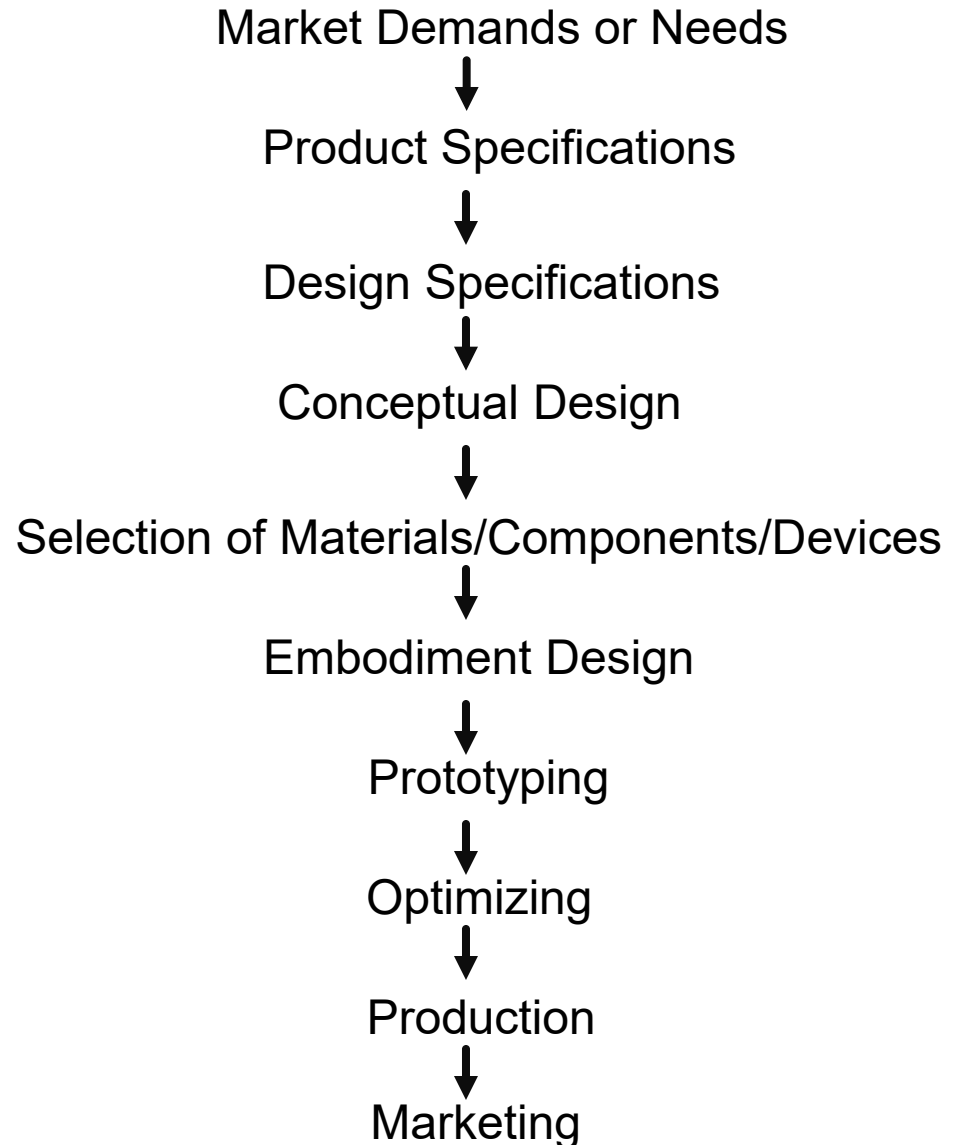

What are you going to study in this course?

- Module 1: Foundation of AI Sensors
- Basics of Physical World
 - Randomness of Physical World
 - Basics of Conceptual Worlds
 - Fuzziness of Conceptual Worlds

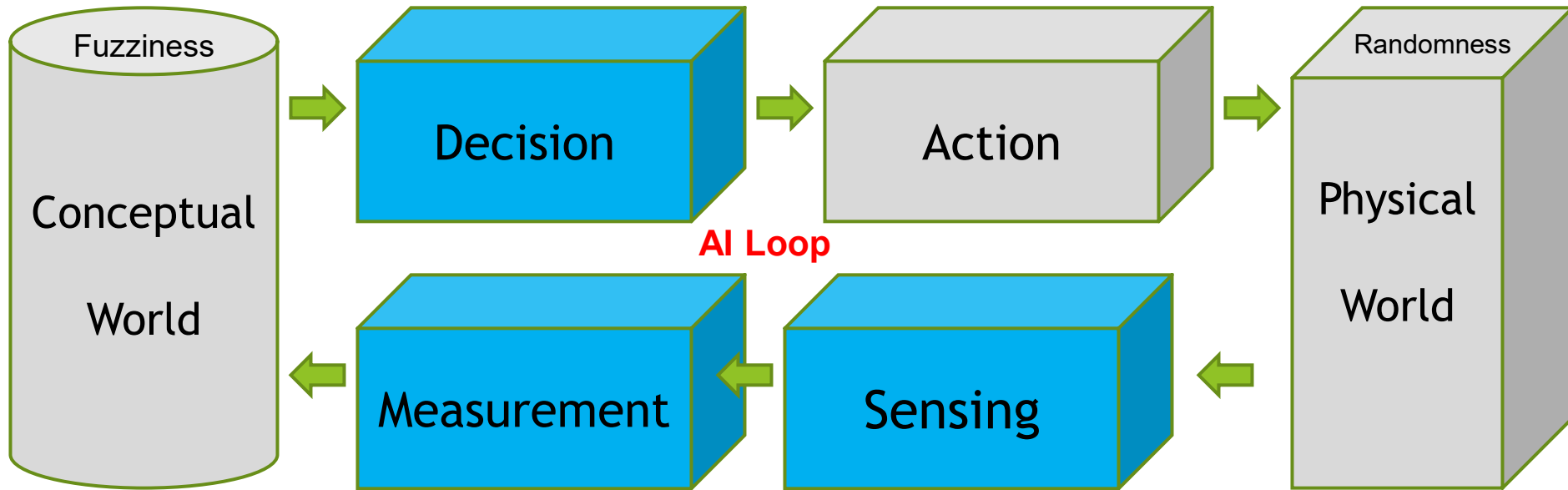

Module 2: For Electrical Systems

- Measurement of Voltage
- Measurement of Current
- Measurement of Resistance
- Measurement of Capacitance
- Measurement of Inductance

Module 3: For Mechanical Systems

- Measurement of Position
- Measurement of Velocity
- Measurement of Acceleration
- Measurement of Force
- Measurement of Torque

Module 4: For All Environments

- Measurement of Pressure
- Measurement of Temperature
- Measurement of Humidity
- Measurement of Vibration
- Measurement of Air Quality

Module 5: For All Industries

- Measurement of Fluid Level
- Measurement of Flow Rate
- Measurement of Sound/Voice
- Measurement of Photometry
- Measurement of Geometry

How to apply?

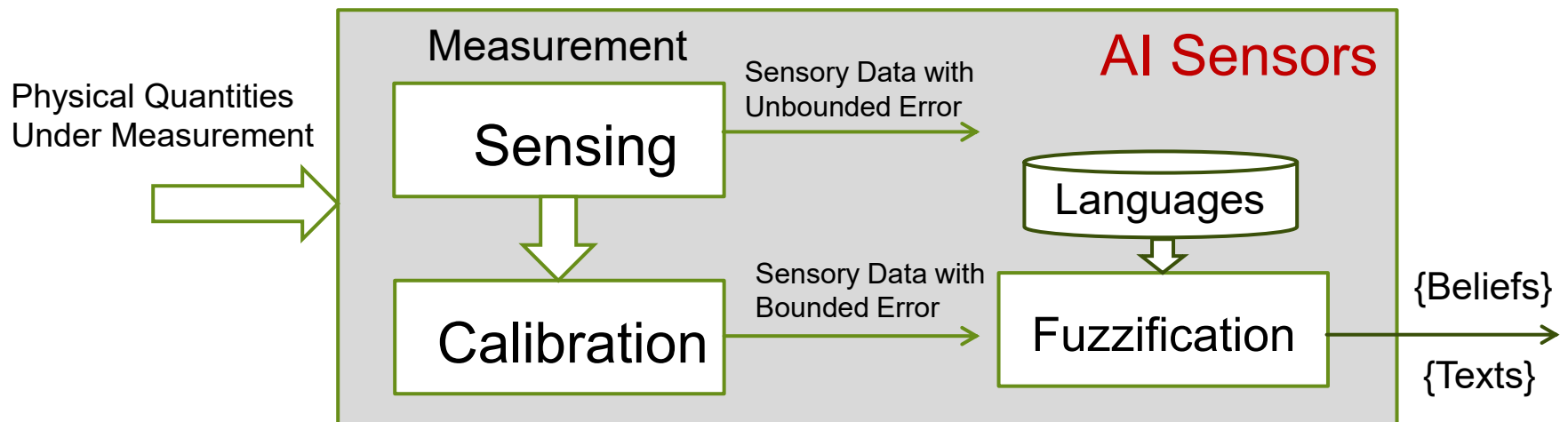
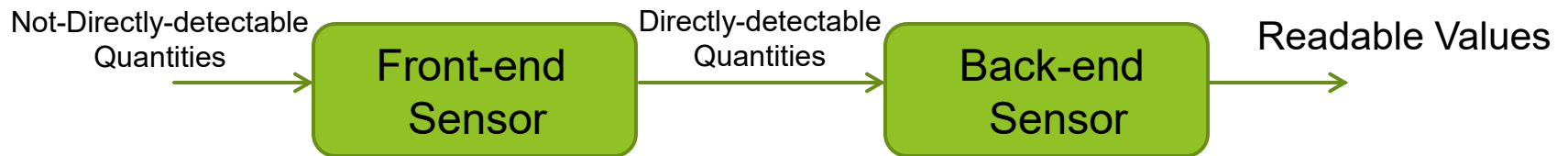

Today's Lectures ...

- ▶ Module 1: Foundation of AI Sensors
- ▶ **Module 2: Sensors for Electrical Systems**
- ▶ Module 3: Sensors for Mechanical Systems
- ▶ Module 4: Sensors for All Environments
- ▶ Module 5: Sensors for All Industries



NANYANG
TECHNOLOGICAL
UNIVERSITY

School of Mechanical & Aerospace Engineering

Design, Machine, Control, Intelligence

Module 2

MA4822

Sensors for Electrical Systems

Xie Ming, PhD (France)

mmxie@ntu.edu.sg

<http://personal.ntu.edu.sg/mmxie>

Outline of Module 2

- ▶ Lecture 1:
 - ▶ Measurement of Voltage
- ▶ Lecture 2:
 - ▶ Measurement of Current
- ▶ Lecture 3:
 - ▶ Measurement of Resistance
- ▶ Lecture 4:
 - ▶ Measurement of Capacitance
- ▶ Lecture 5:
 - ▶ Measurement of Inductance

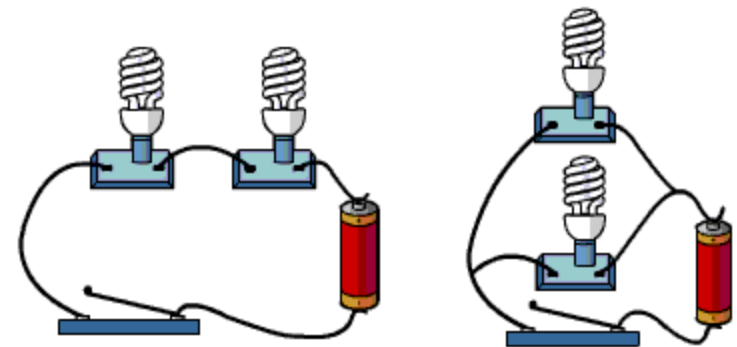

Series Circuit

Parallel Circuit

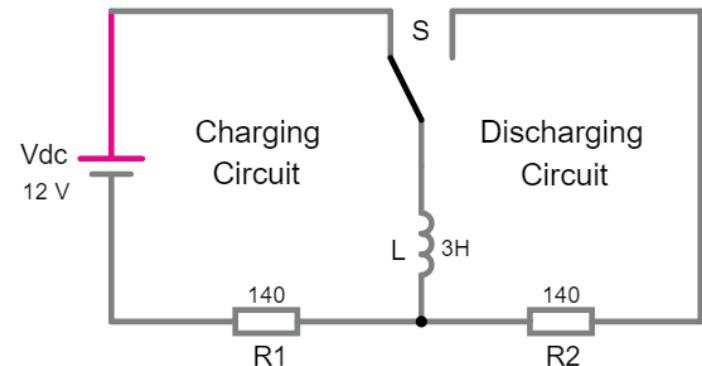

Outline of Module 2

- ▶ Lecture 1:
 - ▶ Measurement of Voltage
- ▶ Lecture 2:
 - ▶ Measurement of Current
- ▶ Lecture 3:
 - ▶ Measurement of Resistance
- ▶ Lecture 4:
 - ▶ Measurement of Capacitance
- ▶ Lecture 5:
 - ▶ Measurement of Inductance

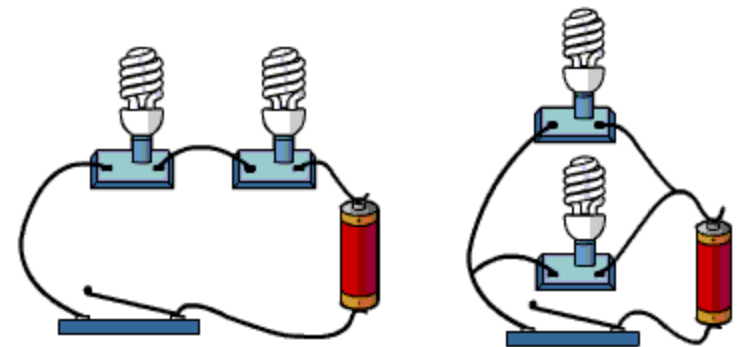

Series Circuit

Parallel Circuit

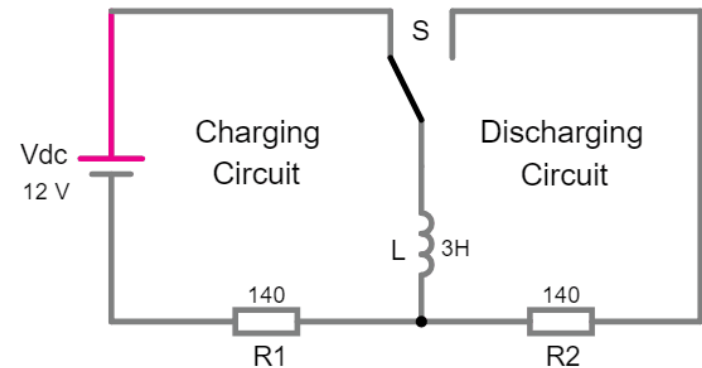



NANYANG
TECHNOLOGICAL
UNIVERSITY

School of Mechanical & Aerospace Engineering

Design, Machine, Control, Intelligence

Module 2 Lecture 1

MA4822

Measurement of Voltage

Xie Ming, PhD (France)

mmxie@ntu.edu.sg

<http://personal.ntu.edu.sg/mmxie>

Outline

- ▶ Electrical Charge
- ▶ Electrical Force
- ▶ Electrical Field
- ▶ Electrical Potential
- ▶ Measurement of Voltage

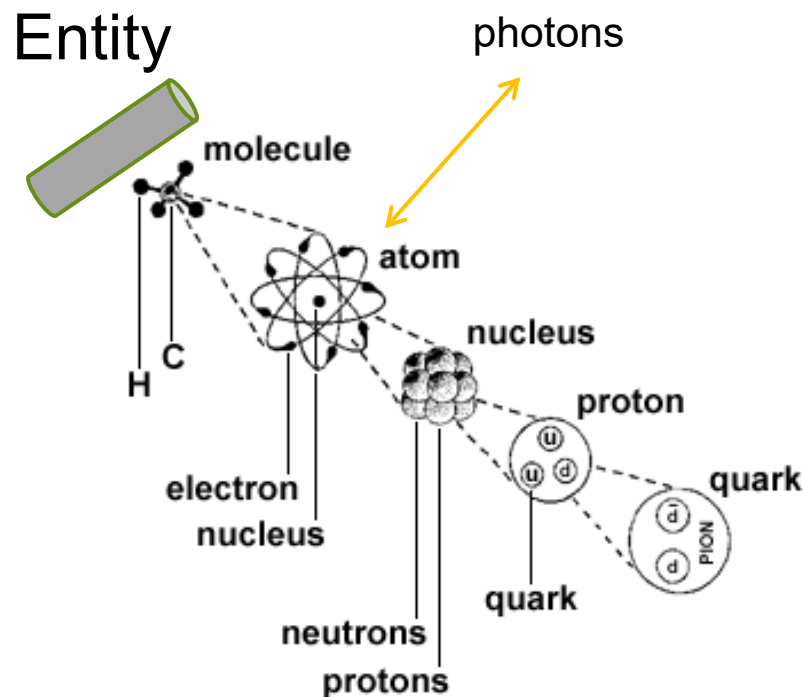
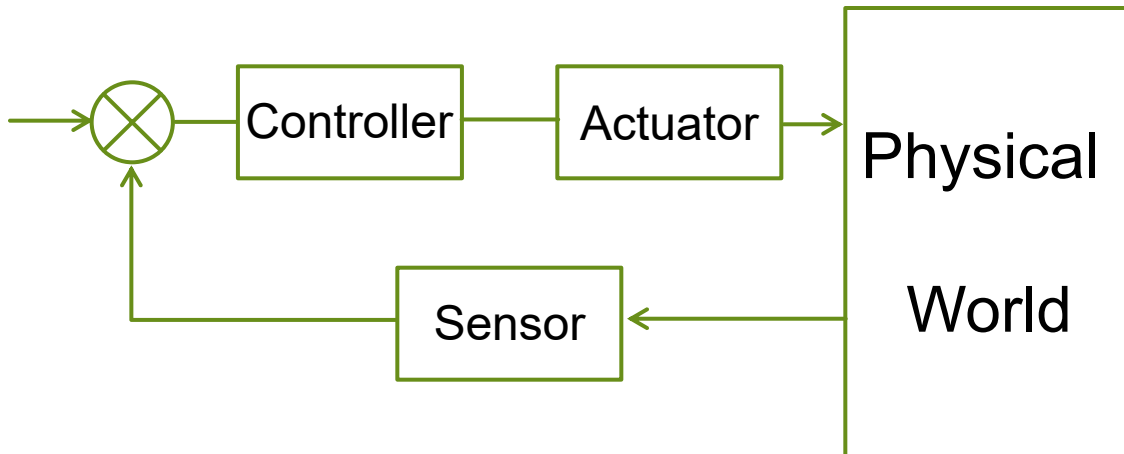

Outline

- ▶ Electrical Charge
- ▶ Electrical Force
- ▶ Electrical Field
- ▶ Electrical Potential
- ▶ Measurement of Voltage

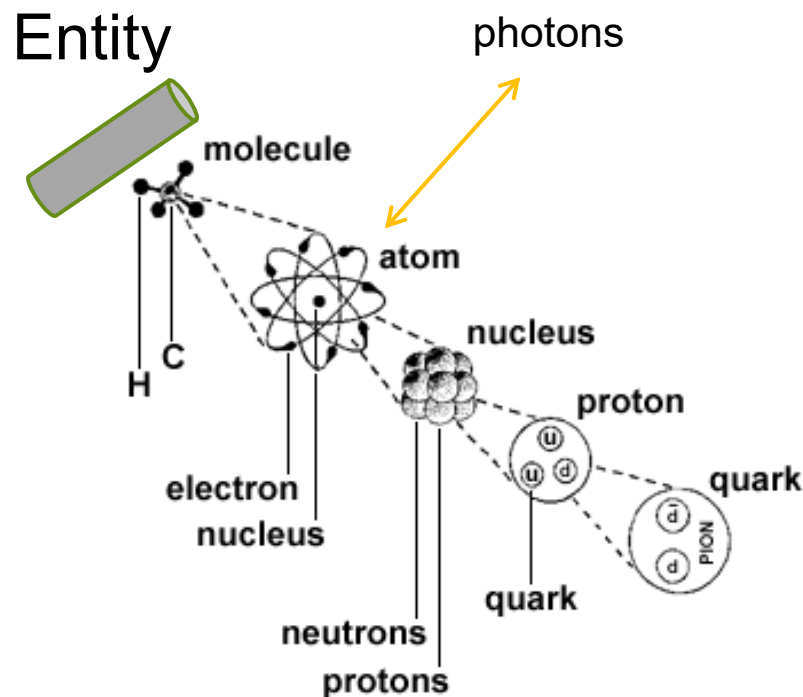
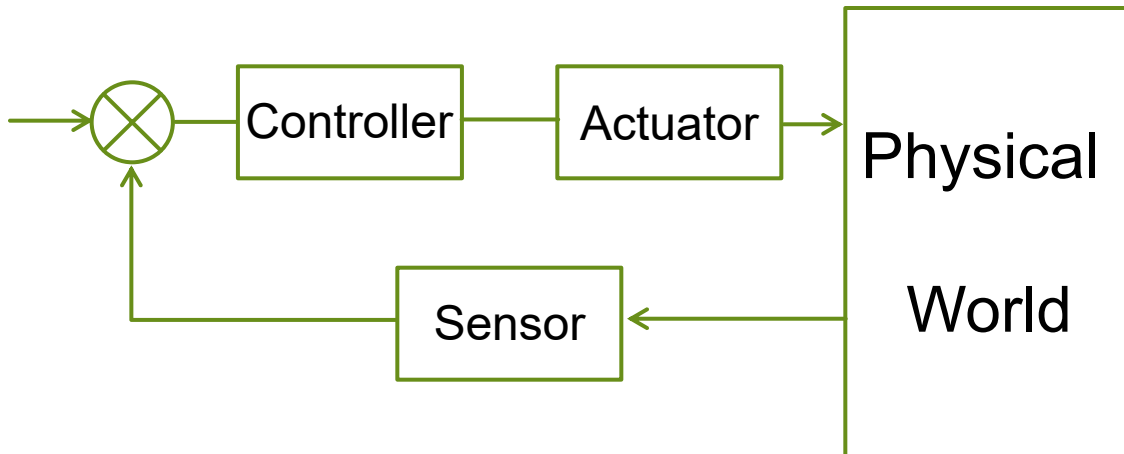

Example of Electric Charges inside Human Bodies ...

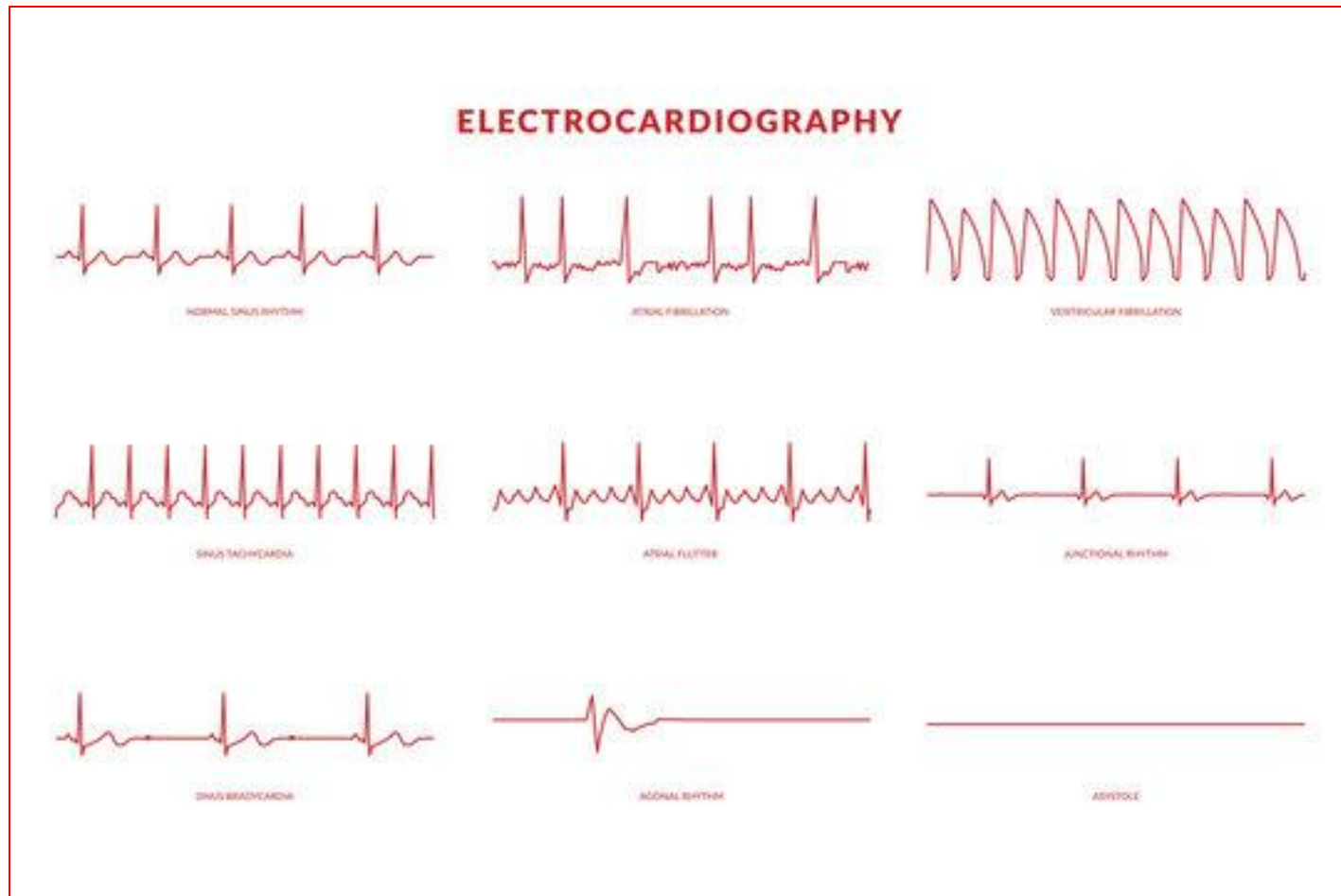

Structure of Matter

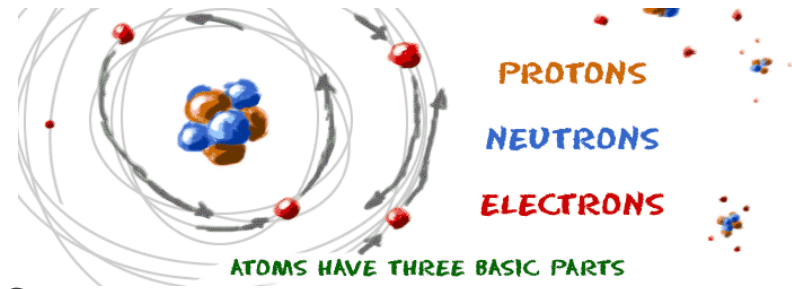

Matters

- ▶ Molecules

- ▶ Atoms

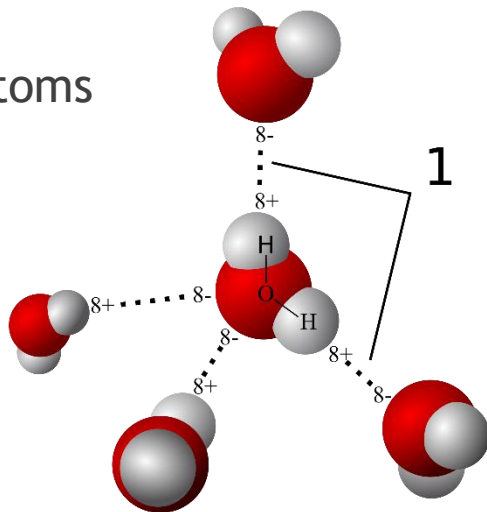

Atoms

- ▶ Electrons

- ▶ Protons
 - ▶ Quarks

- ▶ Neutrons
 - ▶ Quarks



Nucleus

Example of Molecules

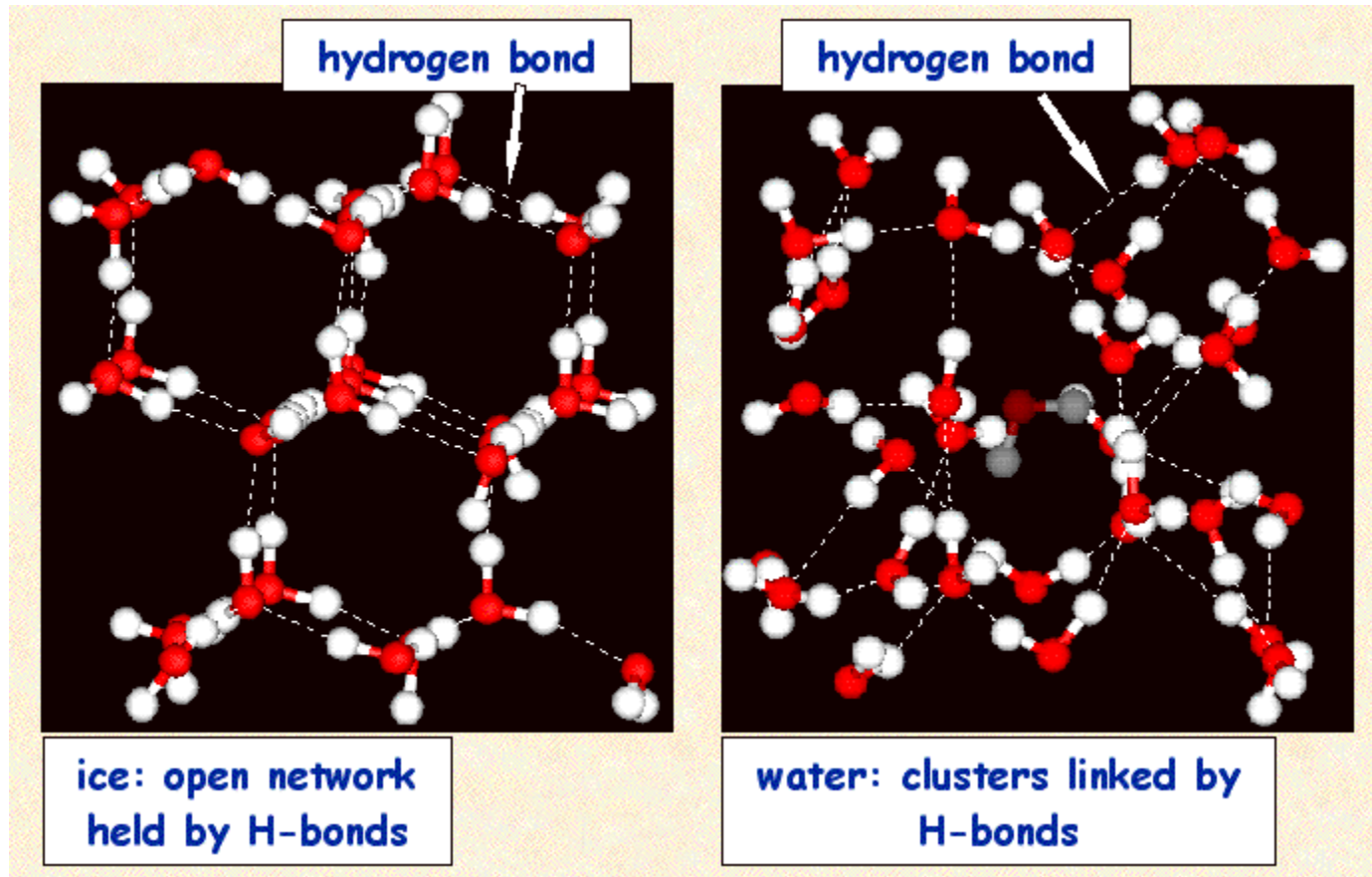

Water in Solid State

Water in Liquid State

Example of Atoms

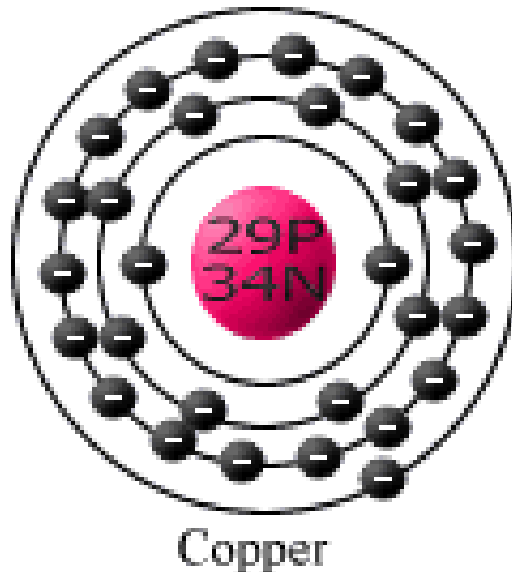
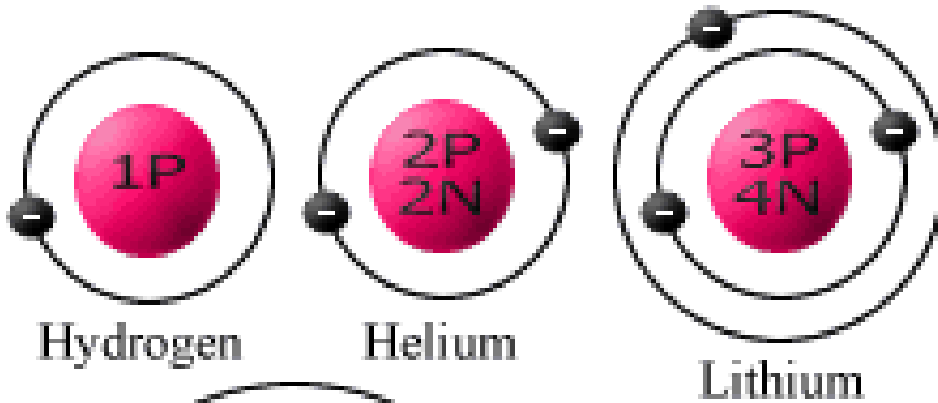

Structure of atoms.

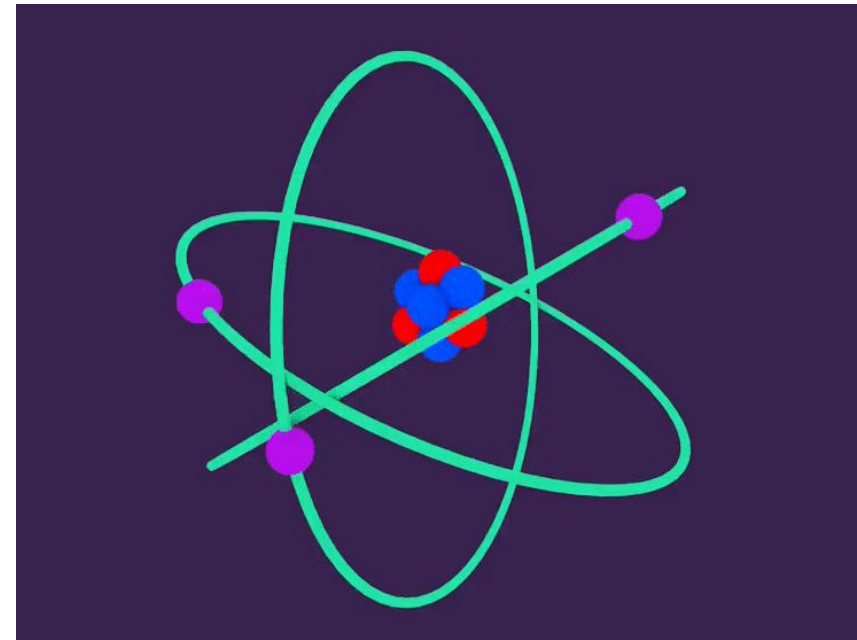

Example of Nucleus

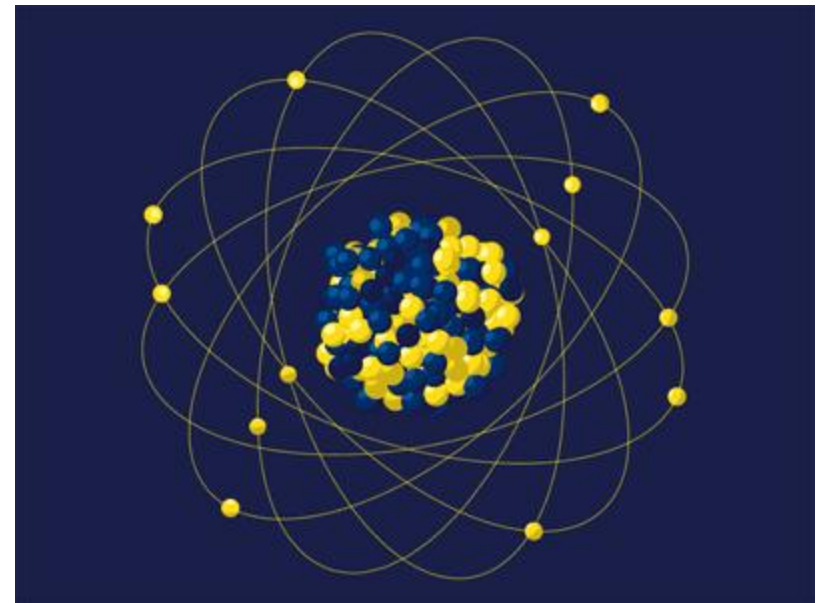
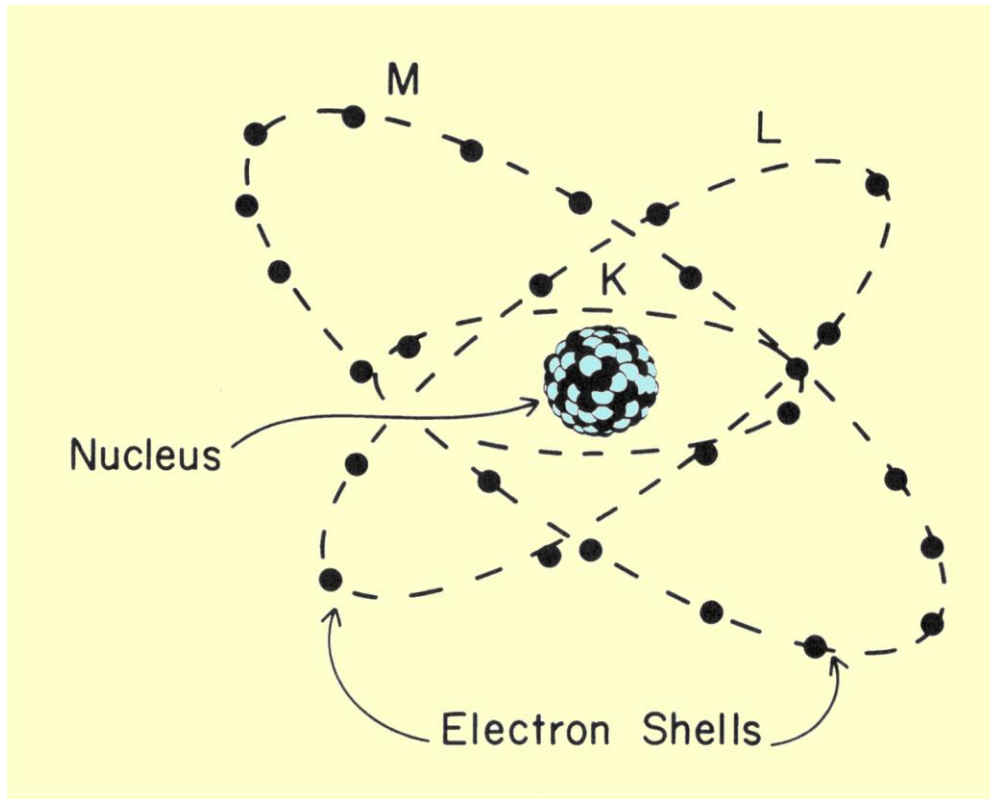

What happens when a neutral atom loses or gains an electron?

► Answer:

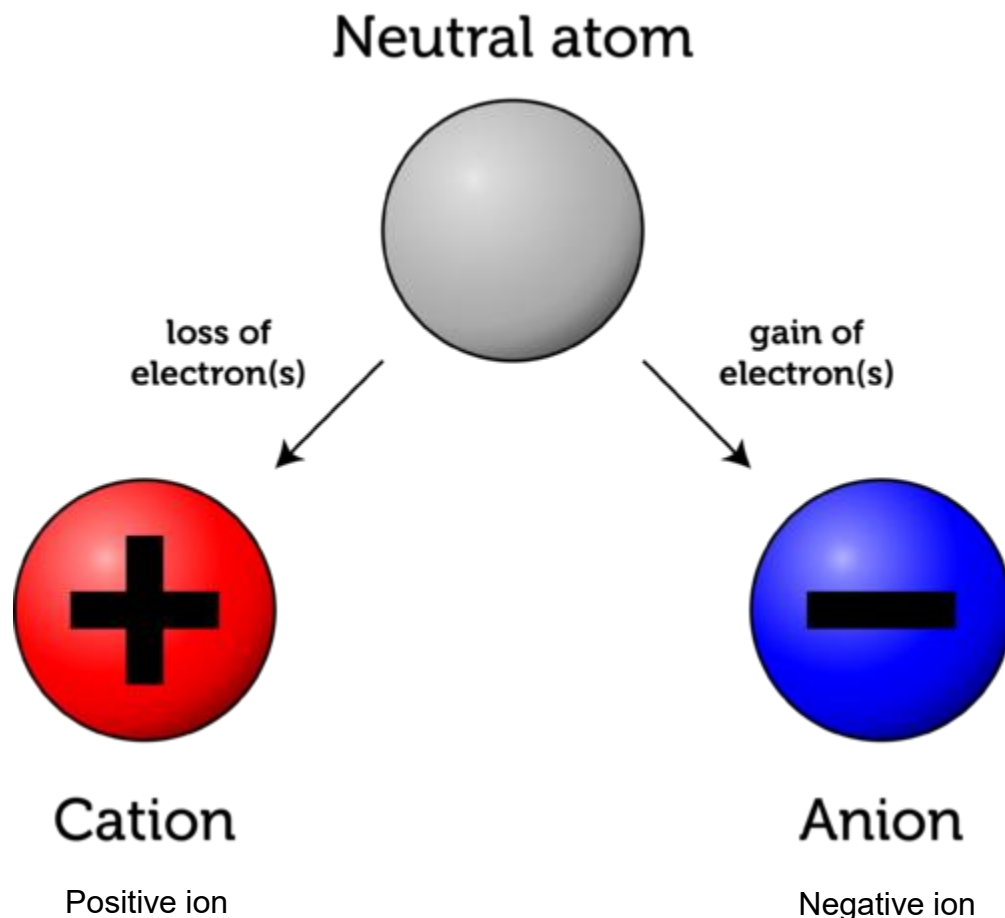

Definition of Electrical Charges

- ▶ When a neutral atom loses electrons, the result is called a positive electrical charge.
 - ▶ A proton itself is a positive electrical charge!
- ▶ When a neutral atom gains electrons, the result is called a negative electrical charge.
 - ▶ An electron itself is a negative electrical charge!

Properties and Constraints of Electrical Charges

Like charges repel each other



Opposite charges attract each other



Example

Movement due to force of attraction

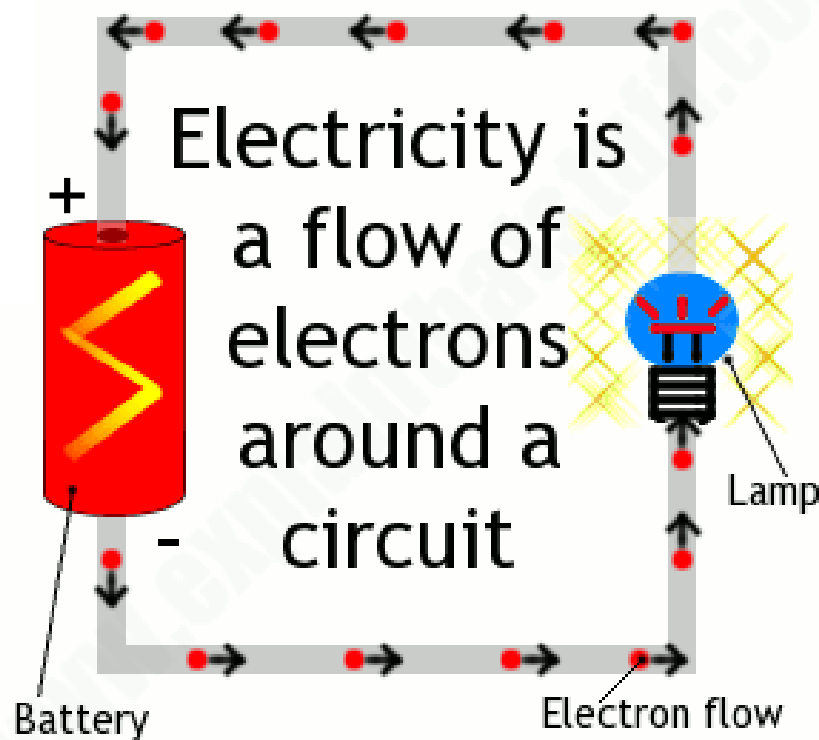

Electrical charges can be induced

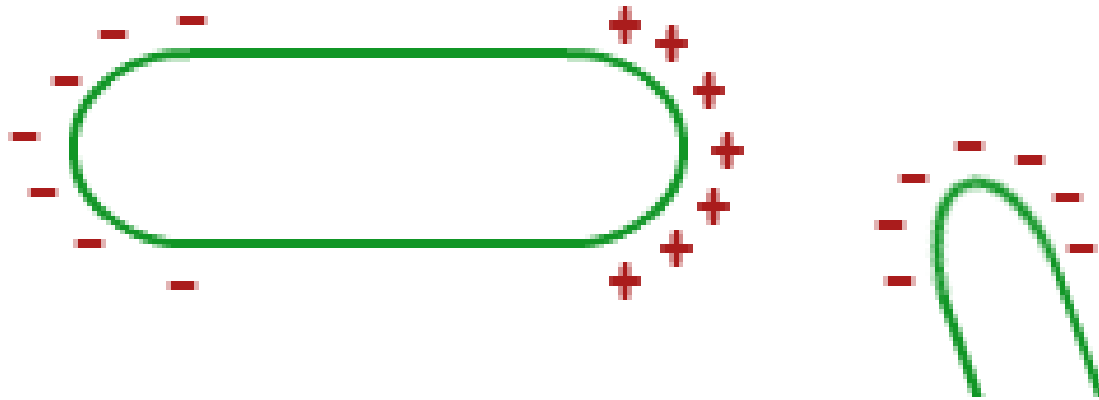

Charged getting concentrated at the ends due to charged particle.

Example of Creating Positive Charges

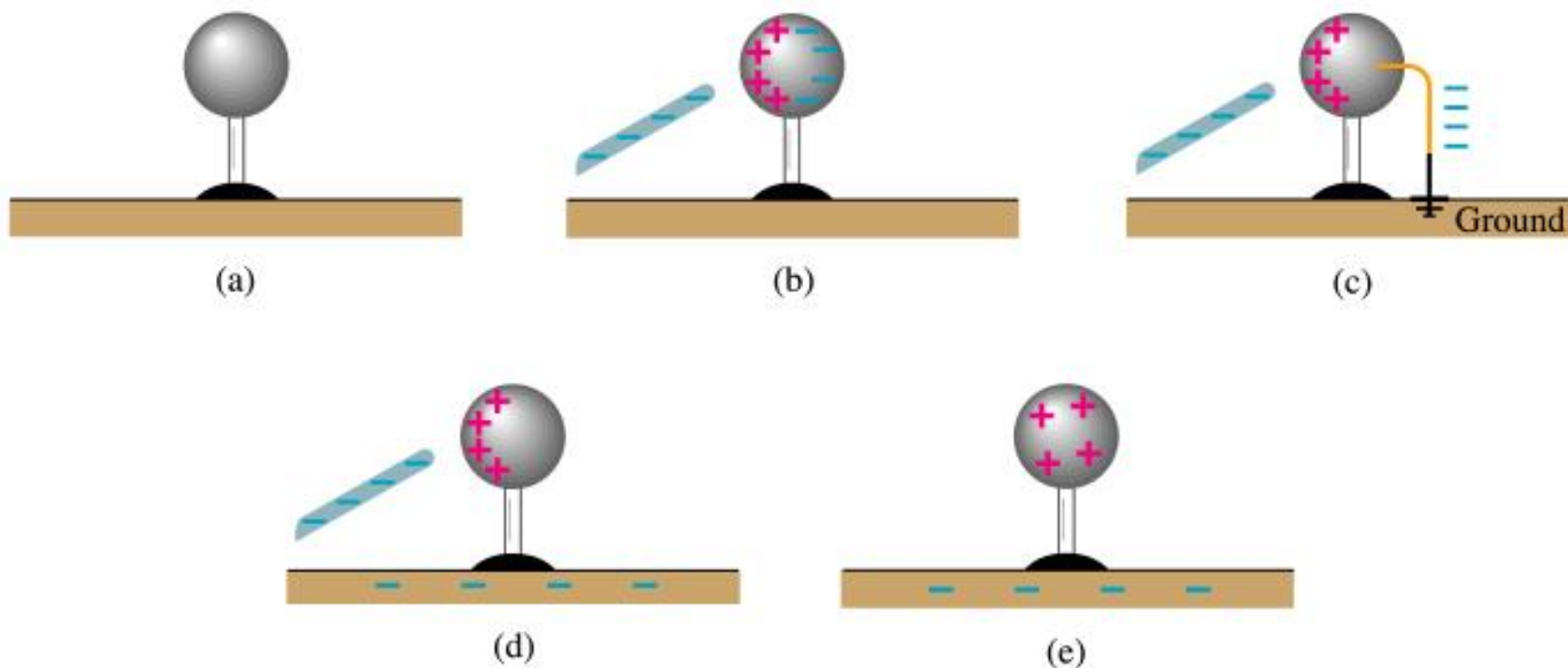

Outline

- ▶ Electrical Charge
- ▶ Electrical Force
- ▶ Electrical Field
- ▶ Electrical Potential
- ▶ Measurement of Voltage

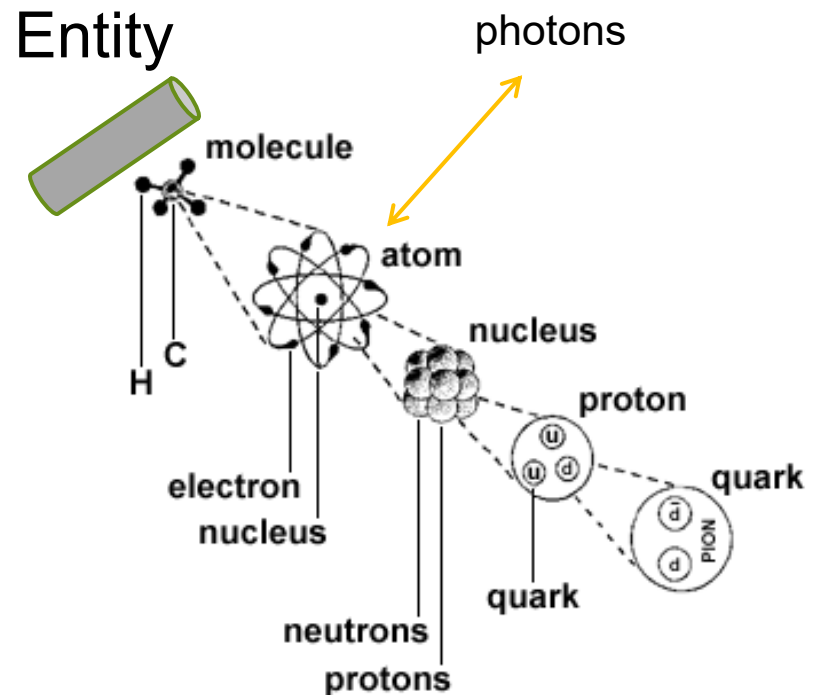
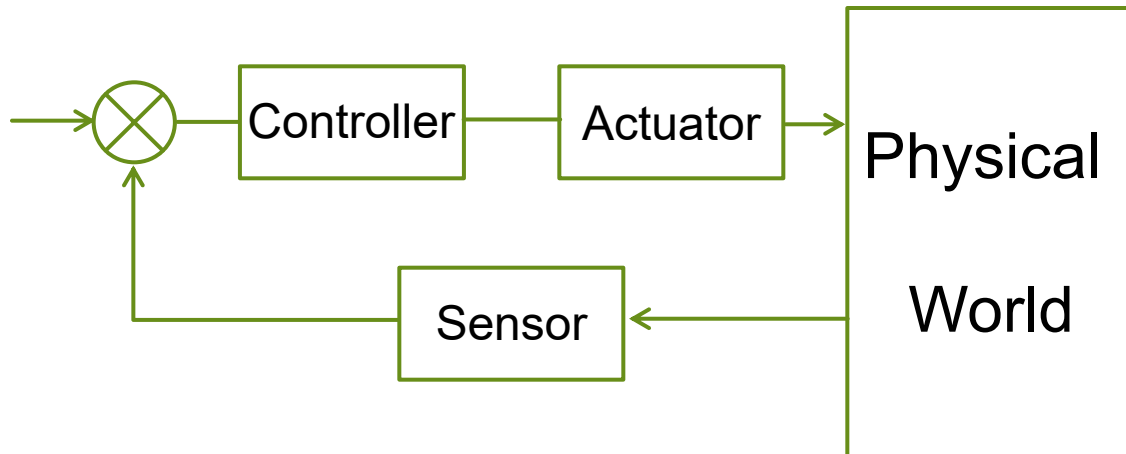

Coulomb's Law

- ▶ Charles Augustin de Coulomb (1736-1806) has done the study about the interaction force between charges.
- ▶ He has discovered that the interaction force is proportional to charges and inversely proportional to their distance square.

$$F = k \frac{|q_1 q_2|}{r^2}$$

Unit of Charge

- ▶ One unit of charge is one Coulomb, denoted as C
- ▶ 1 C is equal to: 6×10^{18} electrons
- ▶ The charge of one electron is: $1.60217733 \times 10^{-19} C$
- ▶ The charge of one proton is: $1.60217733 \times 10^{-19} C$

Value of k

$$F = k \frac{|q_1 q_2|}{r^2}$$

$$k = 8.988 \times 10^9 \text{ N.m}^2 / \text{C}^2$$

$$k = \frac{1}{4\pi\epsilon_0} = 9.0 \times 10^9 \text{ N.m}^2 / \text{C}^2$$

$$\epsilon_0 = 8.854 \times 10^{-12} \text{ C}^2 / \text{N.m}^2$$

Example

- ▶ Find the electrical force between charge $q_1=+25\text{nC}$ and $q_2=-75\text{nC}$ if their distance is 3.0cm.
- ▶ Answer:

$$F = k \frac{|q_1 q_2|}{r^2} = 9.0 \times 10^9 \times \frac{25 \times 10^{-9} \times 70 \times 10^{-9}}{(0.03)^2}$$

$$F = 0.019 \text{ N}$$

Outline

- ▶ Electrical Charge
- ▶ Electrical Force
- ▶ Electrical Field
- ▶ Electrical Potential
- ▶ Measurement of Voltage

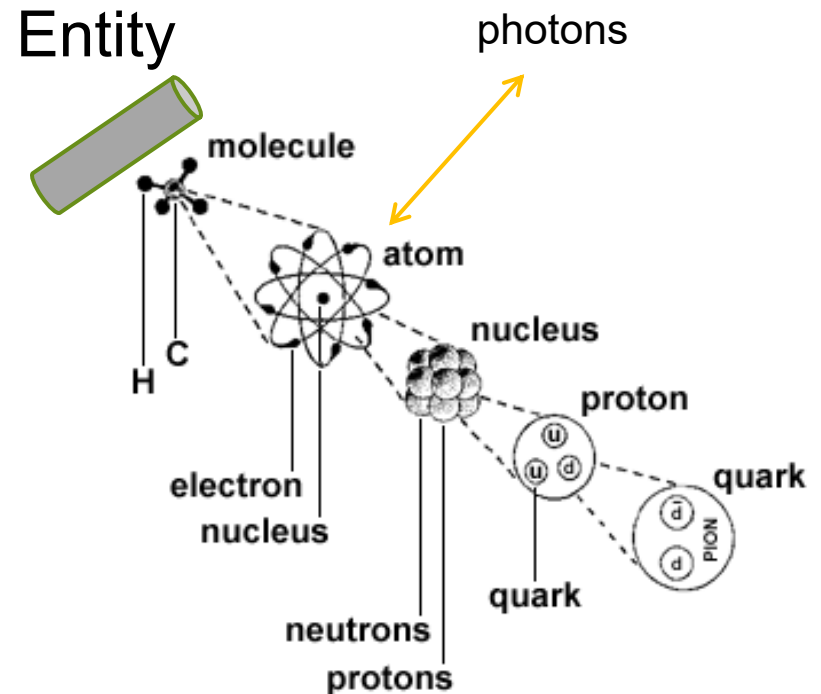
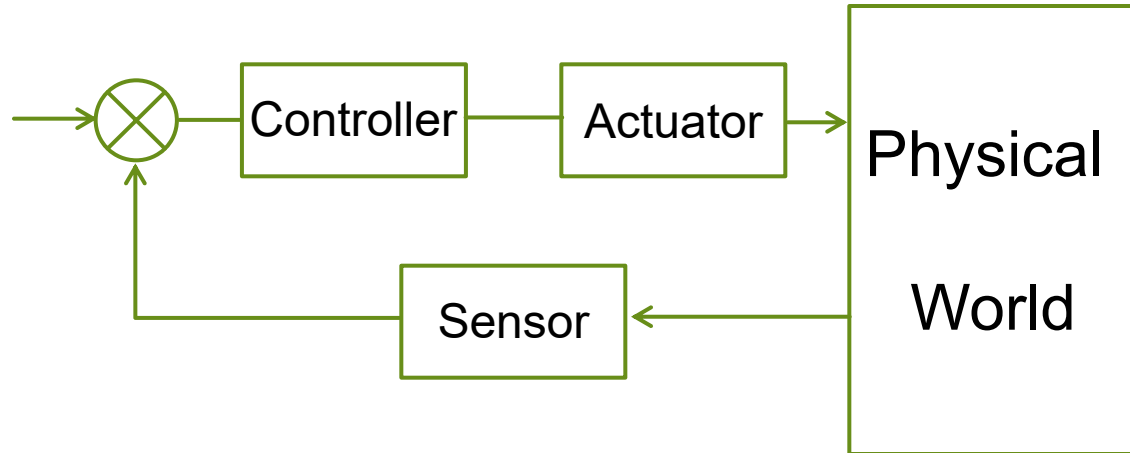

Concept of Electrical Field

- ▶ We have a point charge Q and a unit charge q
- ▶ Then, the electrical force at distance r is:

$$F = k \frac{|Qq|}{r^2} = k \frac{|Q|}{r^2}$$

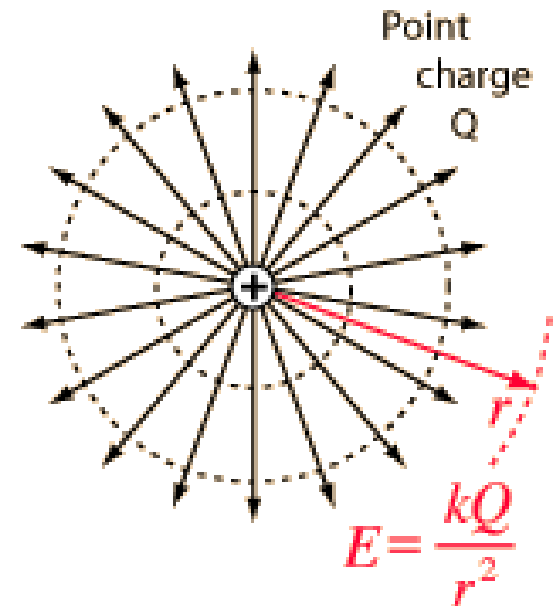

- ▶ Finally, we can define the **force per unit charge** as electrical field density which is a vector:

$$E = k \frac{|Q|}{r^2} \quad \vec{E} = k \frac{|Q|}{r^3} \bullet \vec{r}$$

Definition of Electrical Field

- ▶ A point charge creates a field of forces acting on **unit charges** in its proximity. Such a field of forces is called Electrical Field.
- ▶ The density of electrical field is equal to:

$$E = k \frac{|Q|}{r^2} \qquad \vec{E} = k \frac{|Q|}{r^3} \bullet \vec{r}$$

(vector representation)

Example

- ▶ There is a point with a charge of $Q1$ in a space. If we place another charge of $Q2$ inside the electrical field of $Q1$, what is the force acting on $Q2$ if the distance between the two charges is r ?

- ▶ Answer:

$$E = k \frac{|Q1|}{r^2}$$

$$F = E \bullet Q2 = k \frac{|Q1|}{r^2} \bullet Q2$$

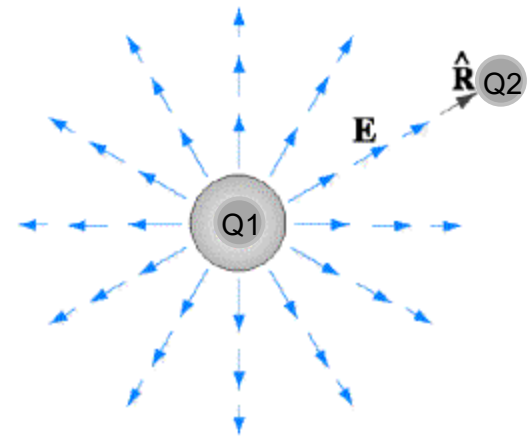

Example

- ▶ We have two charges as shown in the figure. What is the electrical field at the position which is at distance r_1 from q_1 and at distance r_2 from q_2 ?
- ▶ Answer:

$$E_x = E_1 \cos(\alpha) + E_2 \cos(\beta)$$

$$E_y = E_1 \sin(\alpha) + E_2 \sin(\beta)$$

$$\vec{E} = E_x \vec{i} + E_y \vec{j}$$

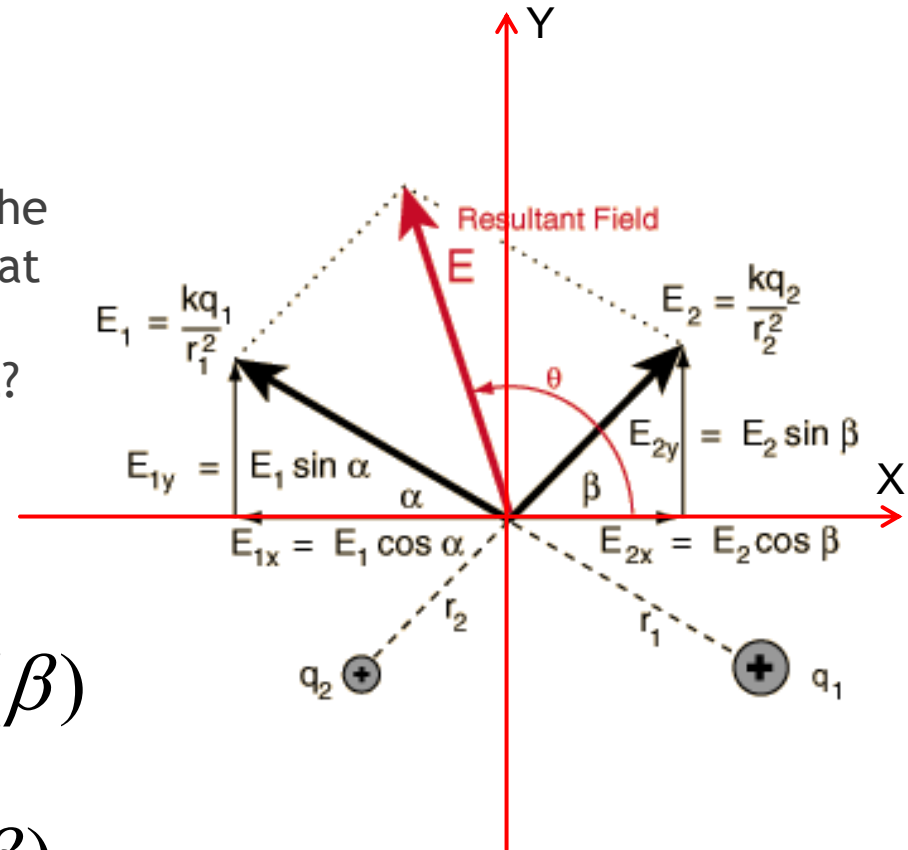

Example

► We have four charges as shown in the figure. What is the electrical field density at point P (imagine a positive unit charge at P)?

► Answer:

$$\vec{E}_P = k \frac{|q_1|}{r_1^3} \bullet \vec{r}_1 + k \frac{|q_2|}{r_2^3} \bullet \vec{r}_2 + k \frac{|q_3|}{r_3^3} \bullet \vec{r}_3 + k \frac{|q_4|}{r_4^3} \bullet \vec{r}_4$$

$$\vec{r}_1 = \frac{R}{\sqrt{2}}(\vec{i} - \vec{j})$$

$$\vec{r}_2 = \frac{R}{\sqrt{2}}(\vec{i} + \vec{j})$$

$$\vec{r}_3 = \frac{R}{\sqrt{2}}(-\vec{i} + \vec{j})$$

$$\vec{r}_4 = \frac{R}{\sqrt{2}}(-\vec{i} - \vec{j})$$

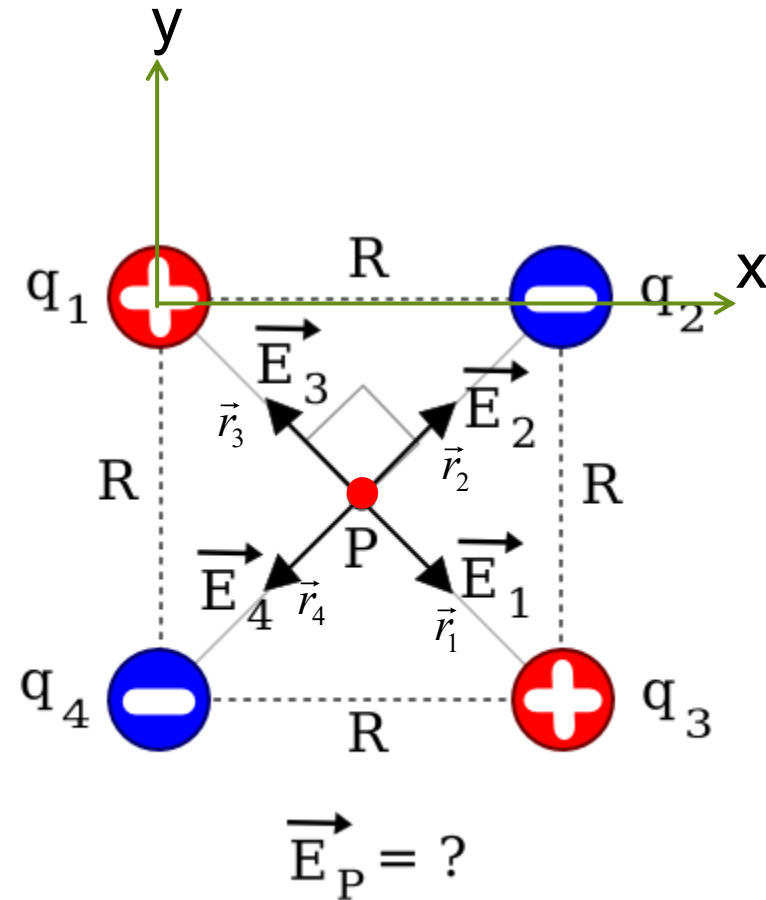

- Repelling forces
- Attracting forces

Outline

- ▶ Electrical Charge
- ▶ Electrical Force
- ▶ Electrical Field
- ▶ Electrical Potential
- ▶ Measurement of Voltage

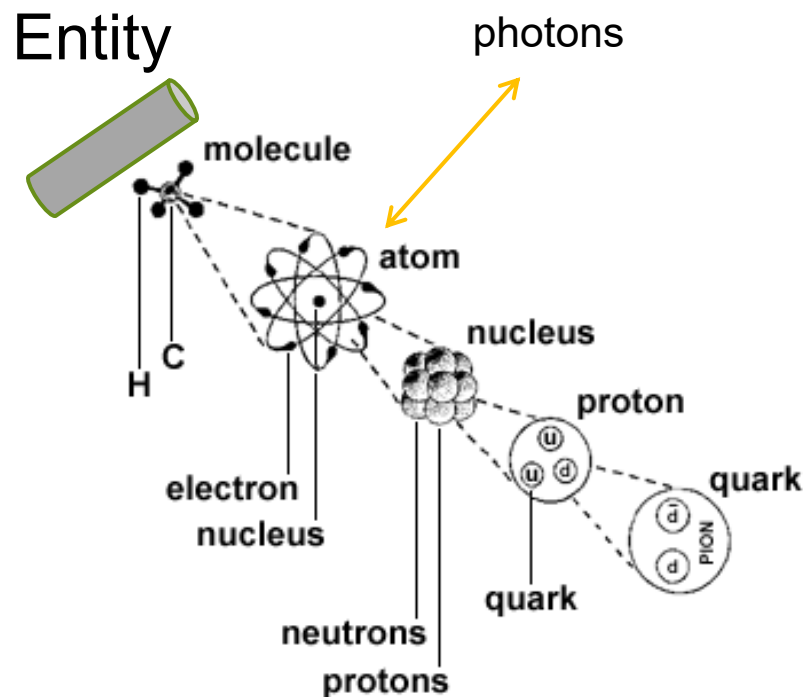
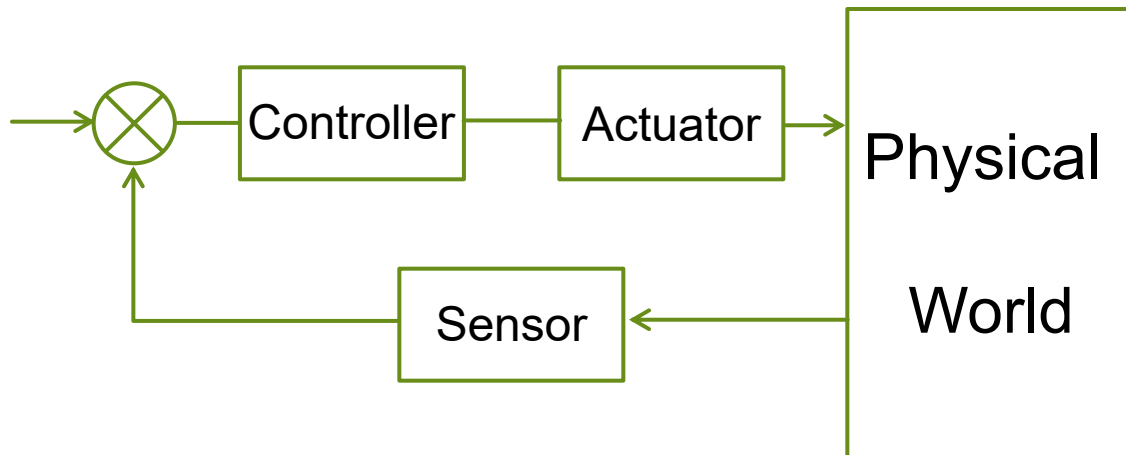

Uniform Electrical Field

- ▶ When the electrical field is constant in magnitude and parallel in direction, such electrical field is an uniform electrical field.

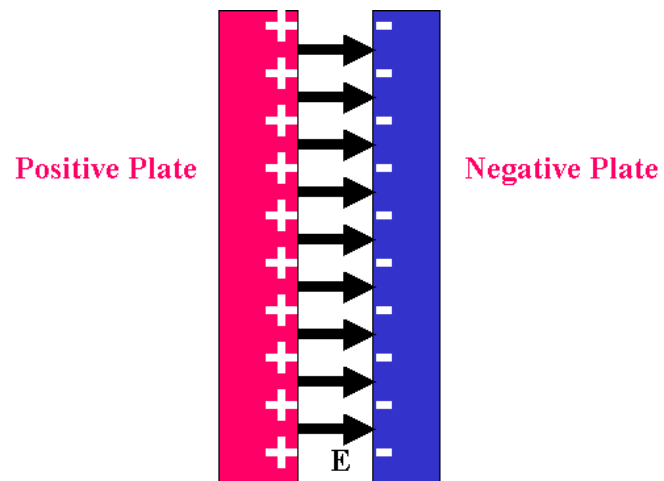

Electrical Potential Energy

- ▶ In an uniform electrical field, work done by an external force which moves a charge q from an initial position Y_i to a final position Y_f is equal to the variation of the so-called electrical potential energy.

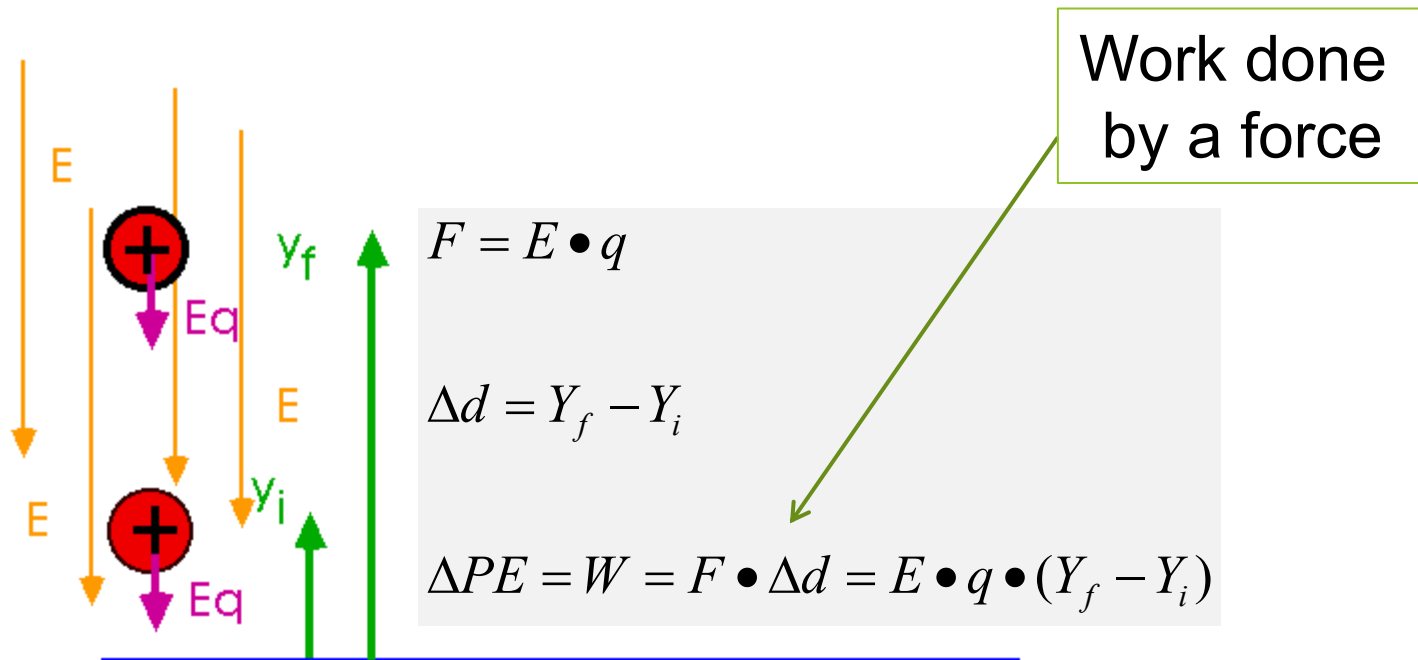

Definition of Electrical Potential Energy

Gravitational Potential Energy = Gravitational Force x Height

- ▶ Electrical **potential energy** of an electrical charge inside an electrical field is equal to **electrical force** times **position** of the electrical charge.

$$U = k \frac{Q}{r^2} q \times r = \frac{kQq}{r}$$

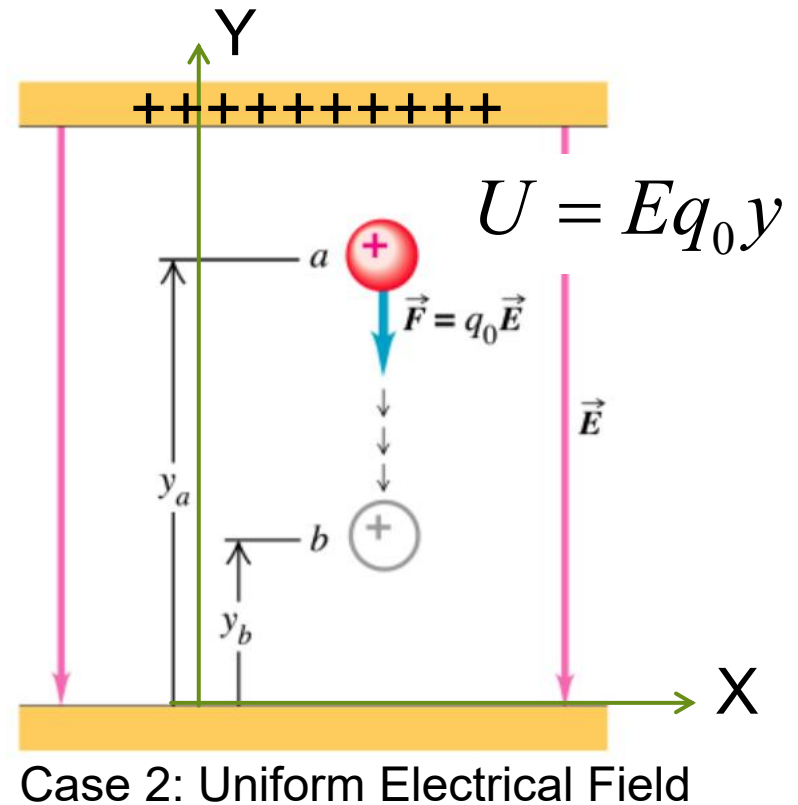
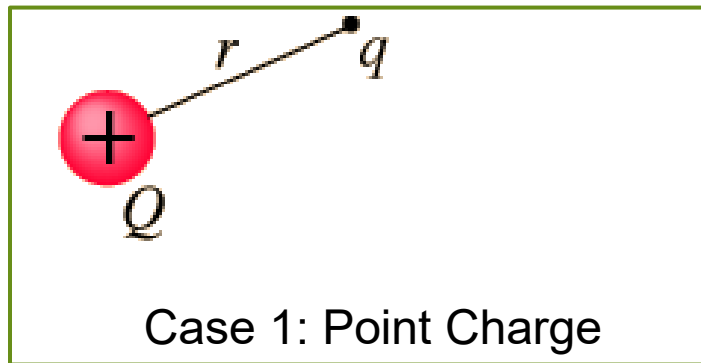

Definition of Electrical Potential

- ▶ The electrical potential energy **per unit charge** is called electrical **potential**, which is also called **voltage**.

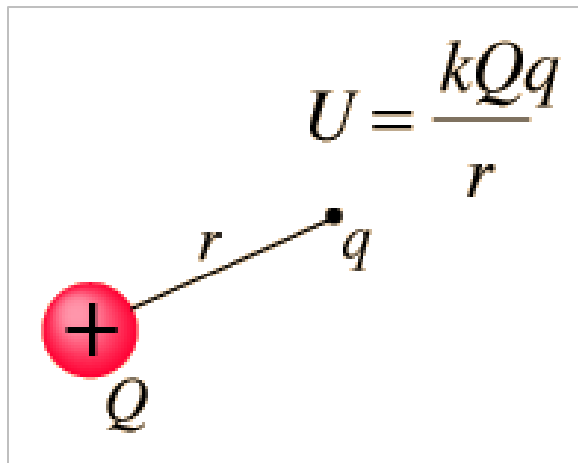

Electrical Potential Energy

If $q = 1$

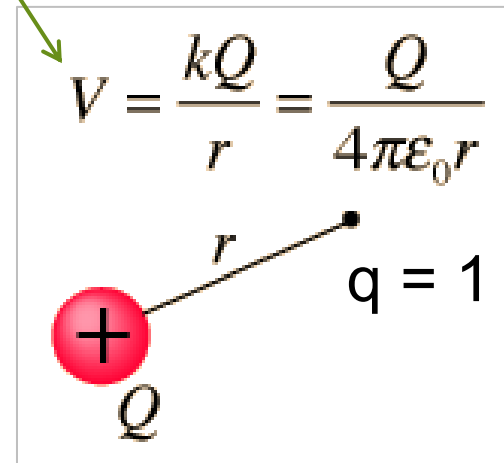

Electrical Potential

Example

- ▶ What is the voltage at distance r_1 from a point charge q_1 ?
- ▶ Answer:

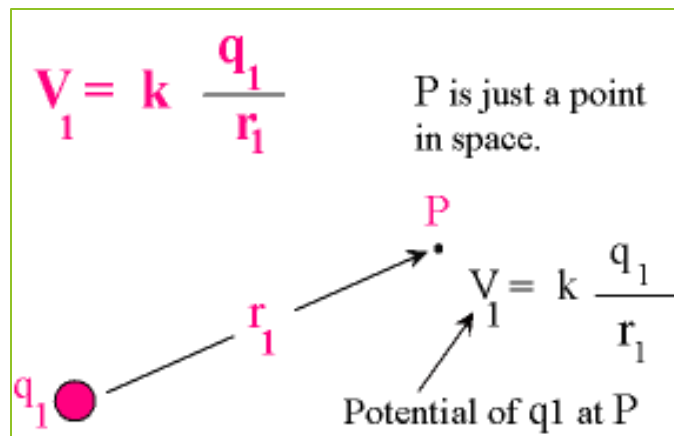

Discussion

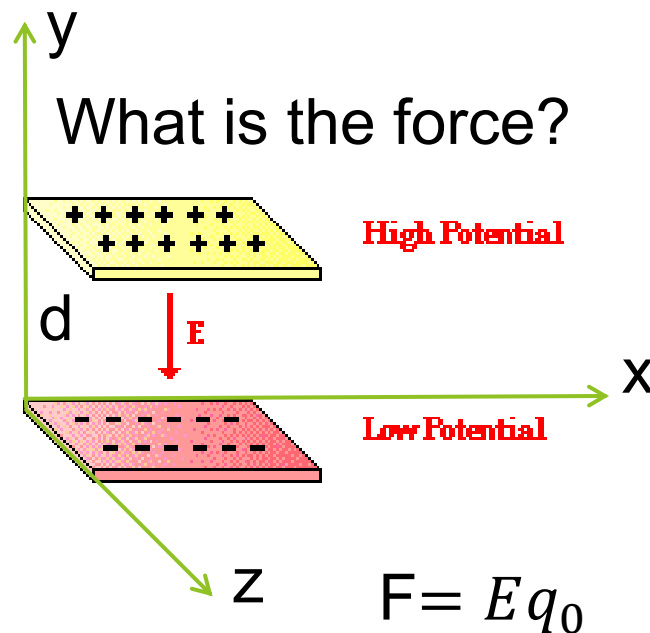

Example

- ▶ What is the electrical potential at a point which is close to three charges as shown in the figure?
- ▶ Answer:

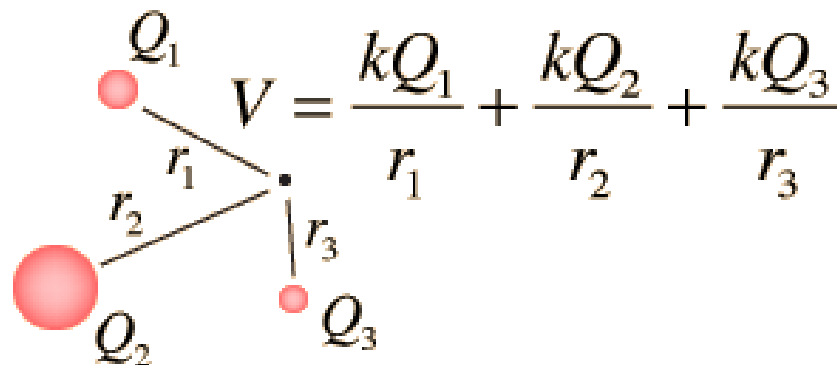

The diagram illustrates three point charges, Q_1 , Q_2 , and Q_3 , represented by red spheres. A central point is marked with a black dot. Lines connect this central point to each charge, with the distances labeled r_1 , r_2 , and r_3 respectively. The charge Q_2 is significantly larger than Q_1 and Q_3 . To the right of the diagram, the formula for the total electrical potential V at the central point is given as:

$$V = \frac{kQ_1}{r_1} + \frac{kQ_2}{r_2} + \frac{kQ_3}{r_3}$$

Example

- ▶ The electrical field between two charged plates is E . If the distance between the two plates is d , what is the difference of voltage between the two plates?

- ▶ Answer:

Electrical potential energy
per unit charge

$$V = \frac{E \bullet q \bullet y}{q} = E \bullet y$$

$$\Delta V = V(y = d) - V(y = 0) = E \bullet d$$

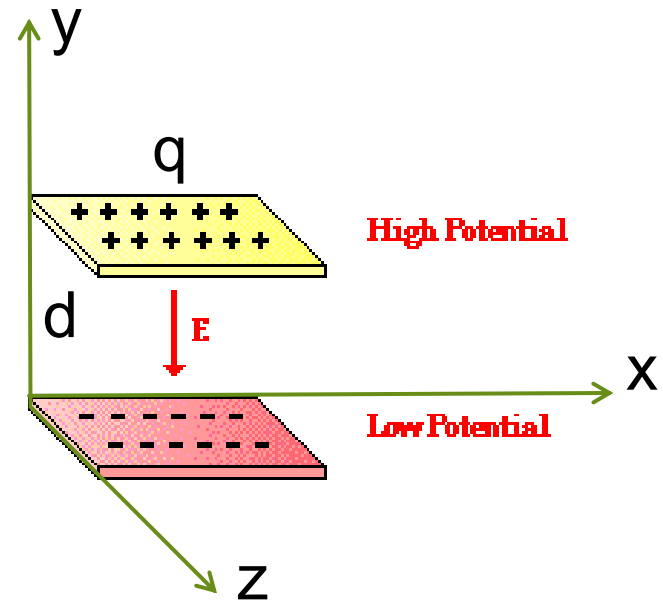

Comparison Between Electrical Field and Gravitational Field

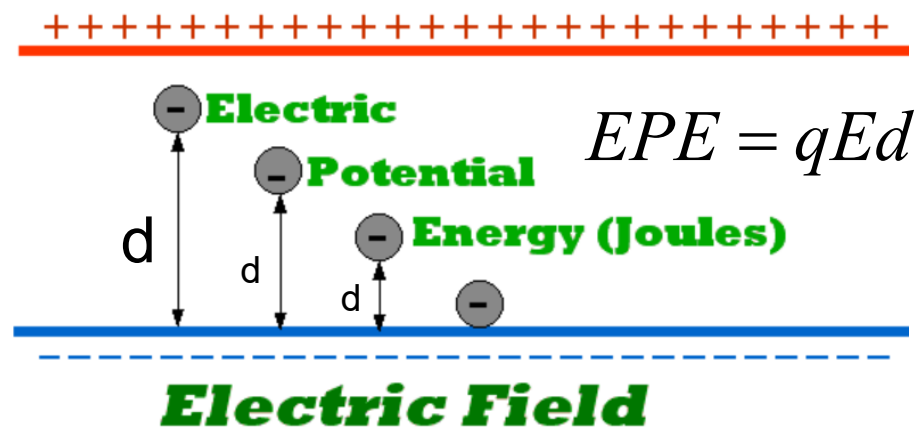
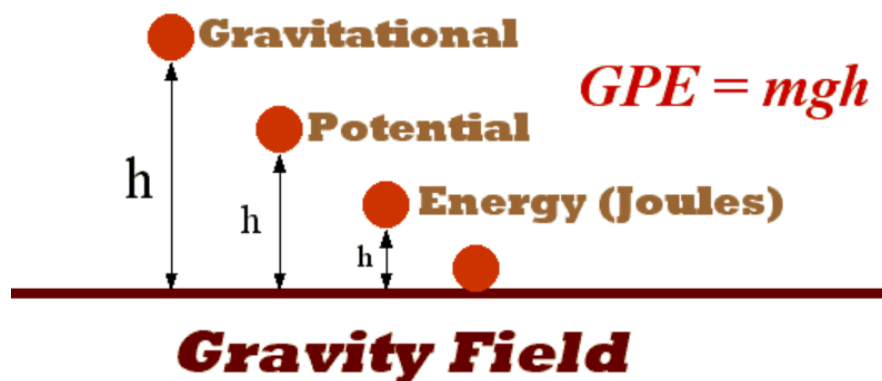

Outline

- ▶ Electrical Charge
- ▶ Electrical Force
- ▶ Electrical Field
- ▶ Electrical Potential
- ▶ Measurement of Voltage

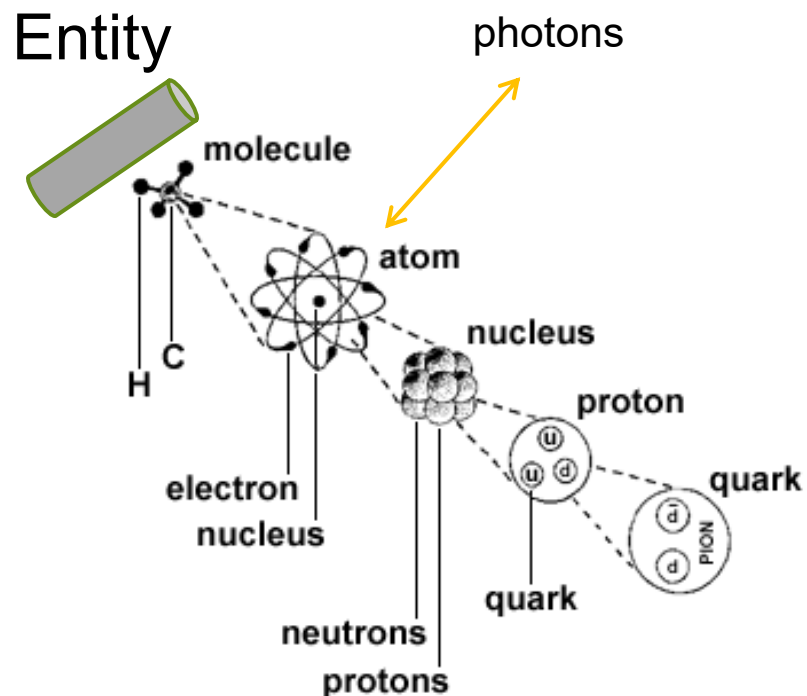
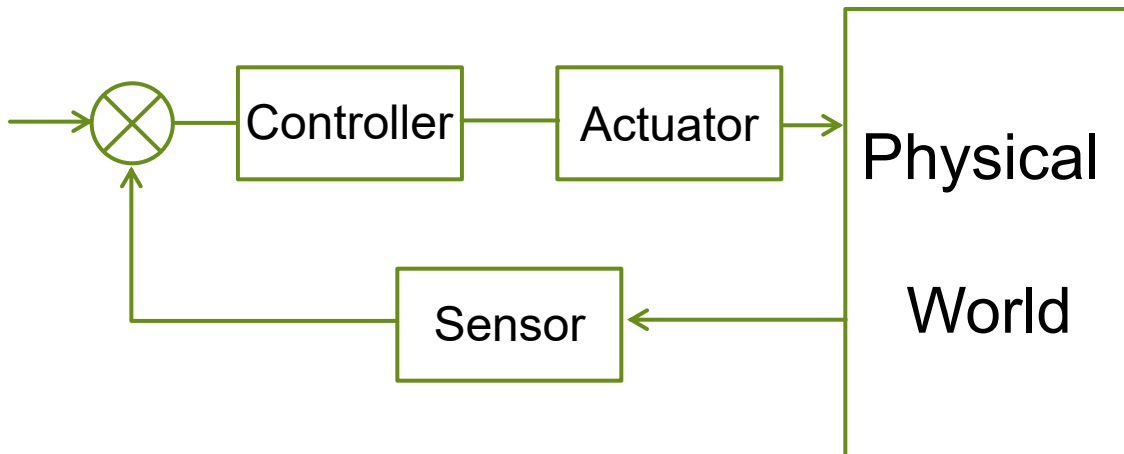

Voltage Generator



Voltage Measurement Inside AC Generator

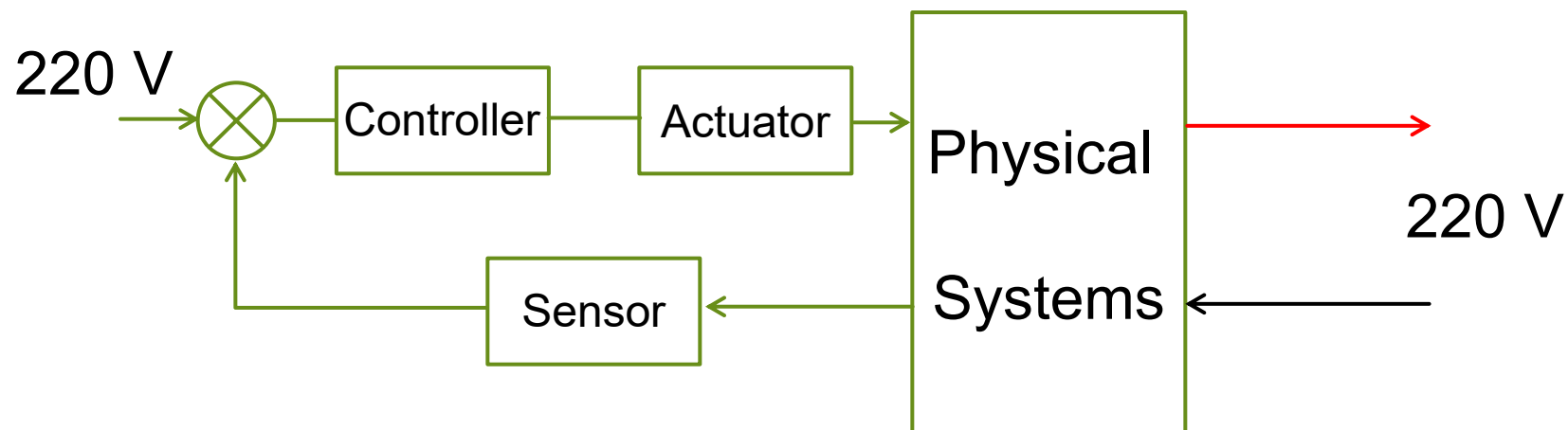

How to convert voltages of alternative currents into voltages of direct currents?

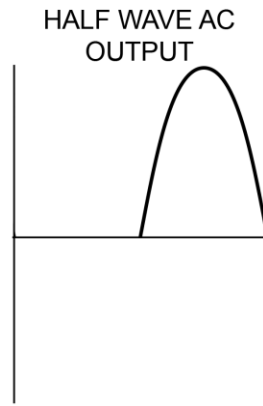
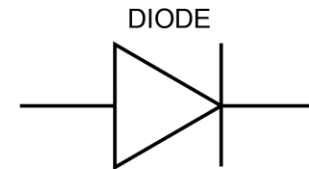
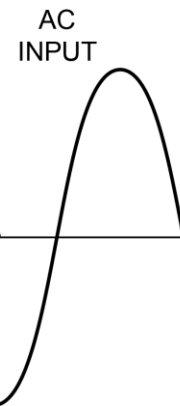
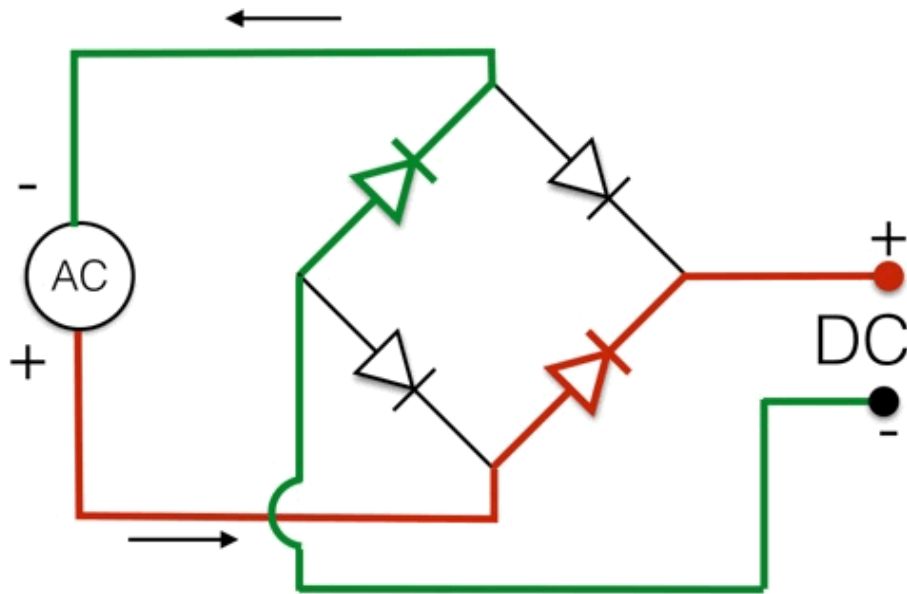

In general, AC-DC conversion involves two devices:

- ▶ 1. Transformer which scales up or down the amplitude of AC voltages
- ▶ 2. Bridge circuit of diodes, which converts sine waves into constant voltages

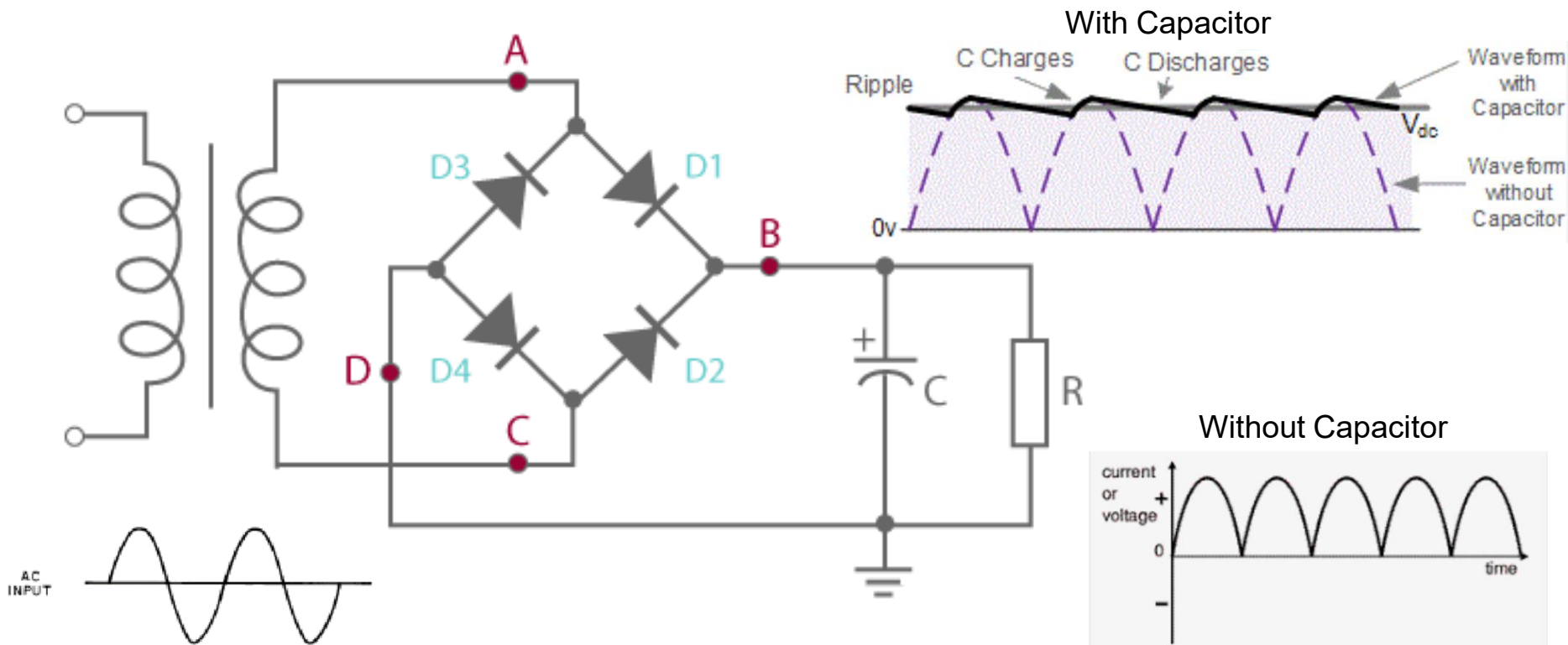

More Solutions ...

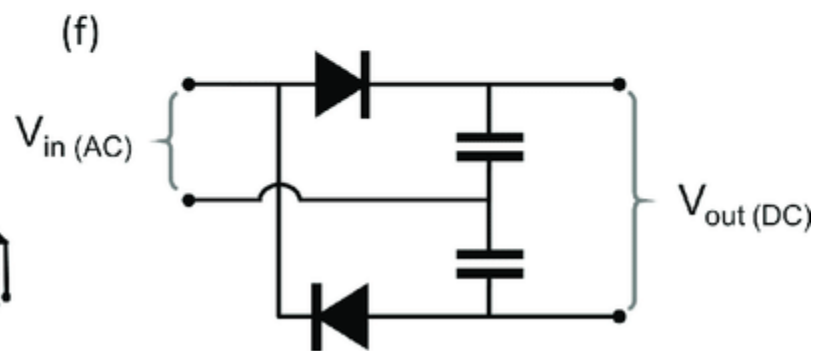
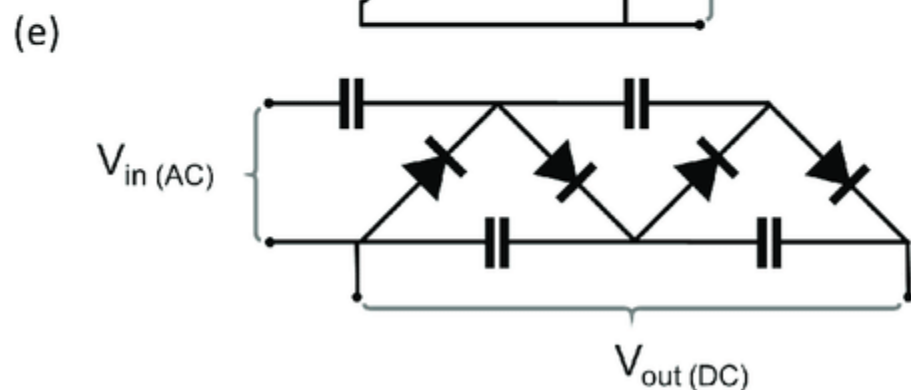
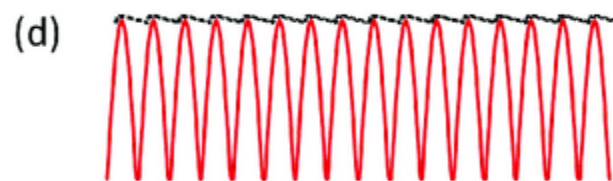
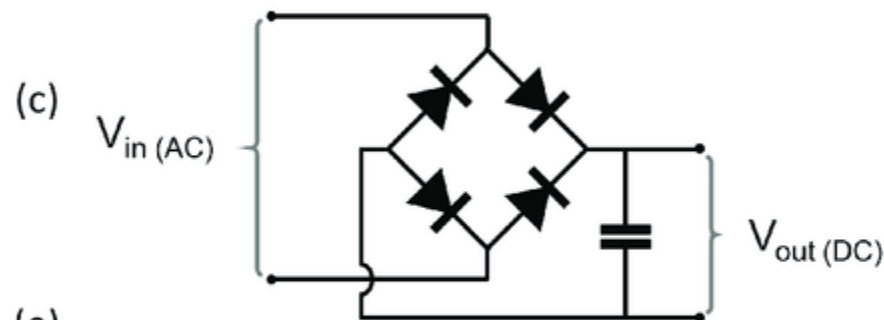
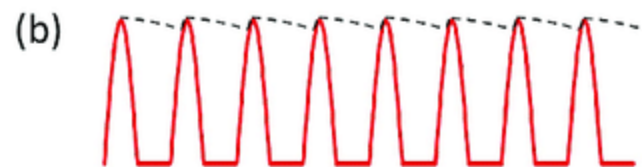
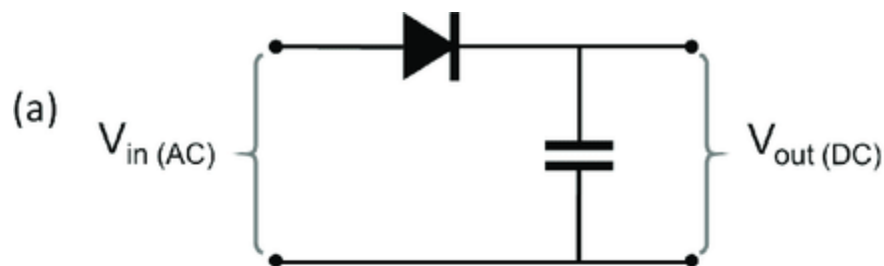

What is the Unit of Measurement of voltage?

- ▶ 1 Volt = 1 Joules/Coulomb
(potential energy per unit charge)

Electric Force $F = \frac{kq_1 q}{r^2} = \text{Newtons}$

Electric Field $E = \frac{F}{q} = \frac{kq_1}{r^2} = \text{Newtons/Coulomb}$

Potential Energy $U = Fr = \frac{kq_1 q}{r} = \text{Joules}$

Potential $V = \frac{Fr}{q} = \frac{kq_1}{r} = \text{Volts}$

How to scale up or down DC voltage?

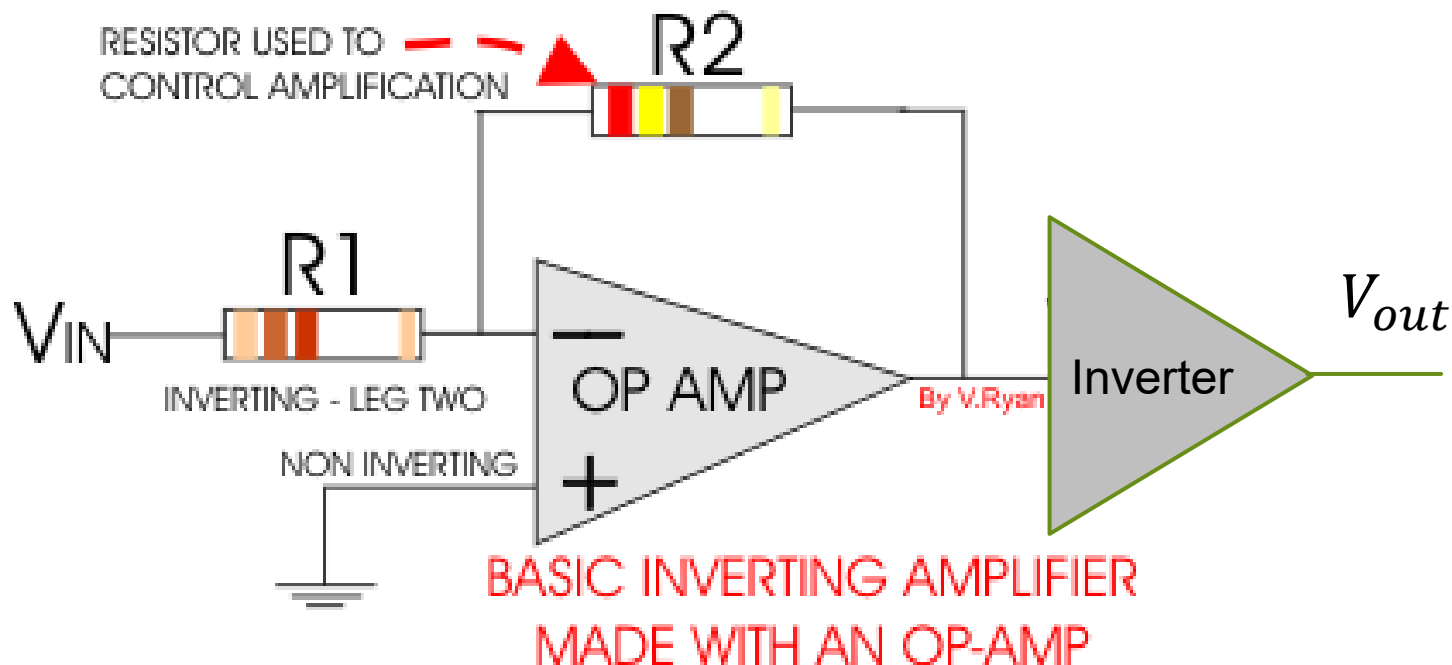

$$V_{out} = \frac{V_{in}}{R_1} \times R_2 = \frac{R_2}{R_1} \times V_{in}$$

Exercise

- ▶ Refer to the previous slide. The resistance value of resistor 2 is 100 K Ohms. The variation range of input voltage is [0.0, 12.0] volts. If the variation range of output voltage has to be [0.0, 3.3] volts, what should be the resistance value of resistor 1?

Answer:

$$V_{out} = \frac{V_{in}}{R_1} \times R_2 = \frac{R_2}{R_1} \times V_{in}$$

$$R_1 = \frac{V_{in}}{V_{out}} \times R_2 = \frac{12.0}{3.3} \times 100 K = 363.636 K \text{ Ohms}$$

How to cope with multiple ranges of voltages to be measured?

- Solution: to use a circuit with multiple pairs of resistor-to-resistor ratio.

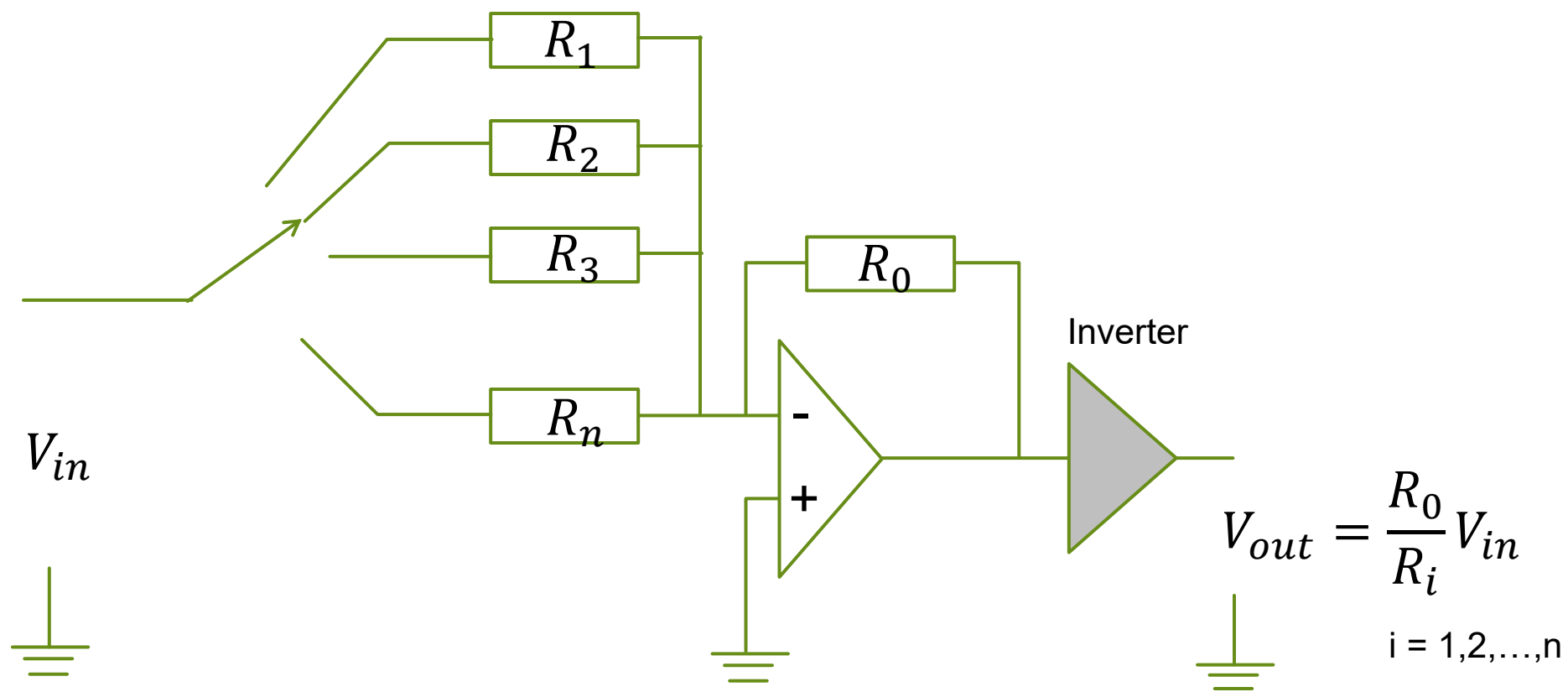

How to convert voltages of a fixed range into computer-readable digital values?

- ▶ To use microcontroller such as ARM Cortex M4
- ▶ Working Principle:
 - ▶ To predict digital value
 - ▶ To generate DC voltage corresponding to each predicted digital value
 - ▶ To compare input voltage with generated voltage
 - ▶ To stop prediction when two voltages are close enough
 - ▶ To read digital value as output

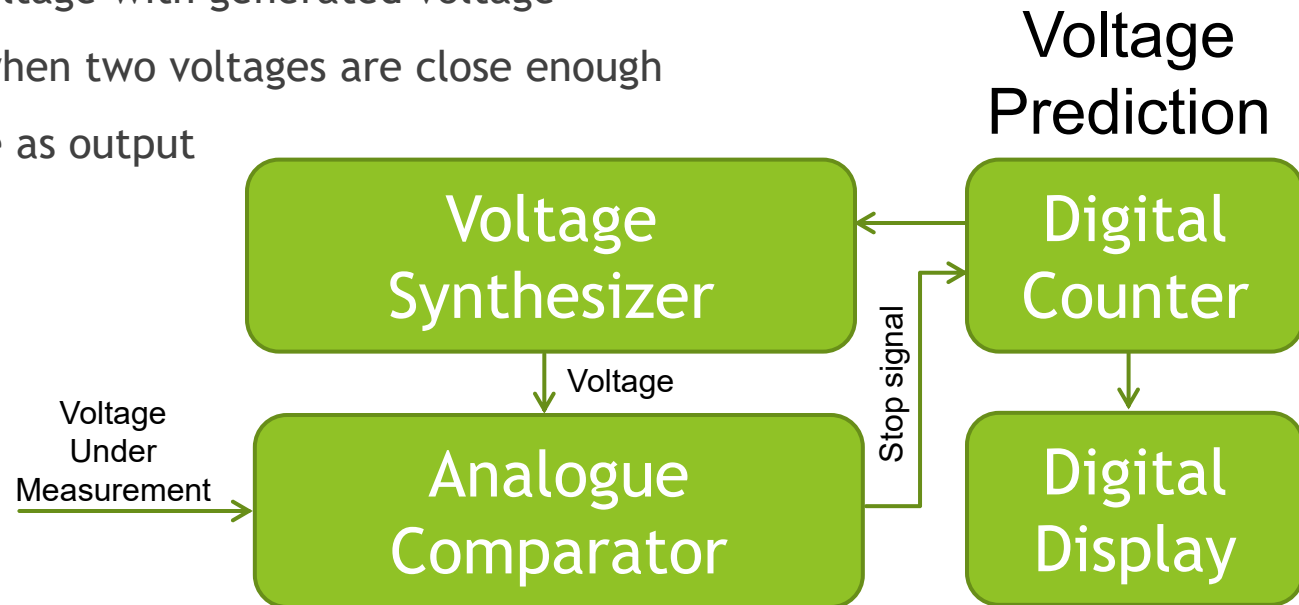

Example of Digital Counter ...

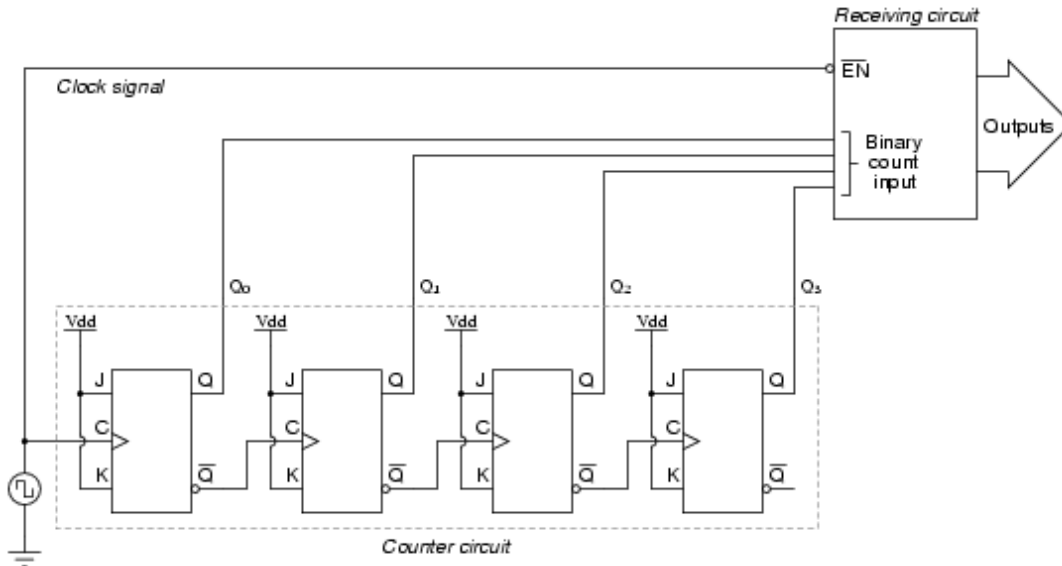

Active Clock Signal: Falling Edge

Q3	Q2	Q1	Q0
0	0	0	0
0	0	0	1
0	0	1	0
0	0	1	1
0	1	0	0
0	1	0	1
0	1	1	0
0	1	1	1
1	0	0	0
1	0	0	1
1	0	1	0
1	0	1	1
1	1	0	0
1	1	0	1
1	1	1	0
1	1	1	1
0	0	0	0

Example of Voltage Synthesizer ...

D/A Converter

A digital system outputs digital values encoded in three bits. A DAC converts these digital numbers into analogue voltages. If we use the circuit as shown in the figure, what is the analogue voltage if the digital value is 111?

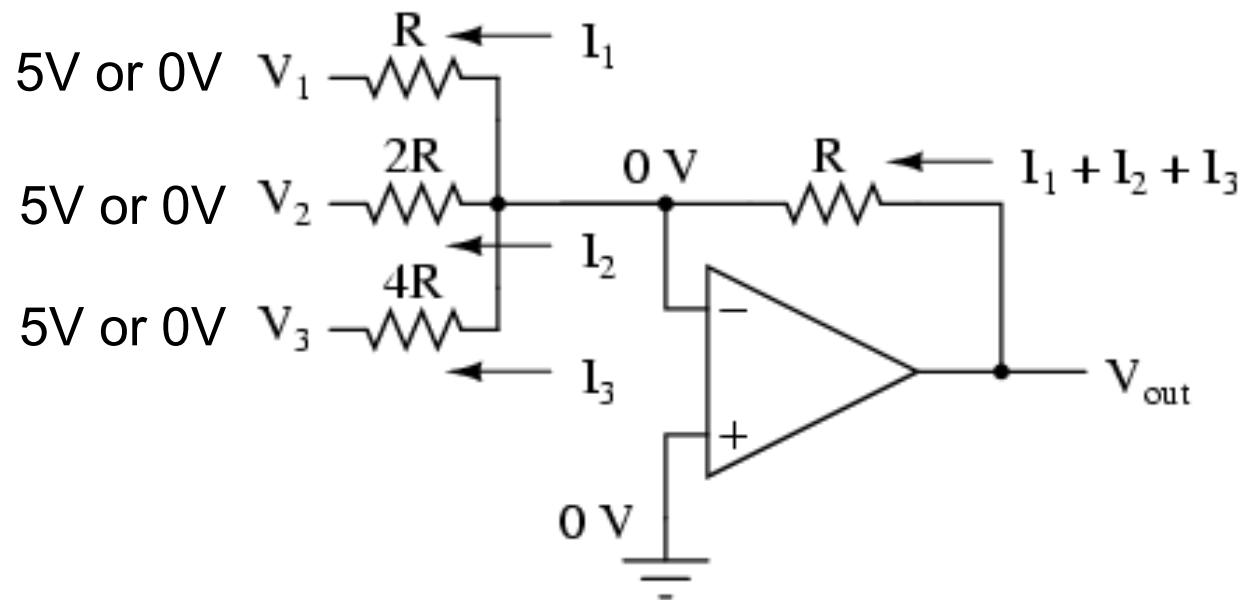

$$V_{out} = - \left(V_1 + \frac{V_2}{2} + \frac{V_3}{4} \right)$$

Exercise

- Refer to the figure below. If the binary input is 1010101, what is the analogue output?
- Answer: $V_{out} = -5000 \times \left(\frac{5}{640,000} + \frac{5}{160,000} + \frac{5}{40,000} + \frac{5}{10,000} \right) = -3.32 \text{ volts}$

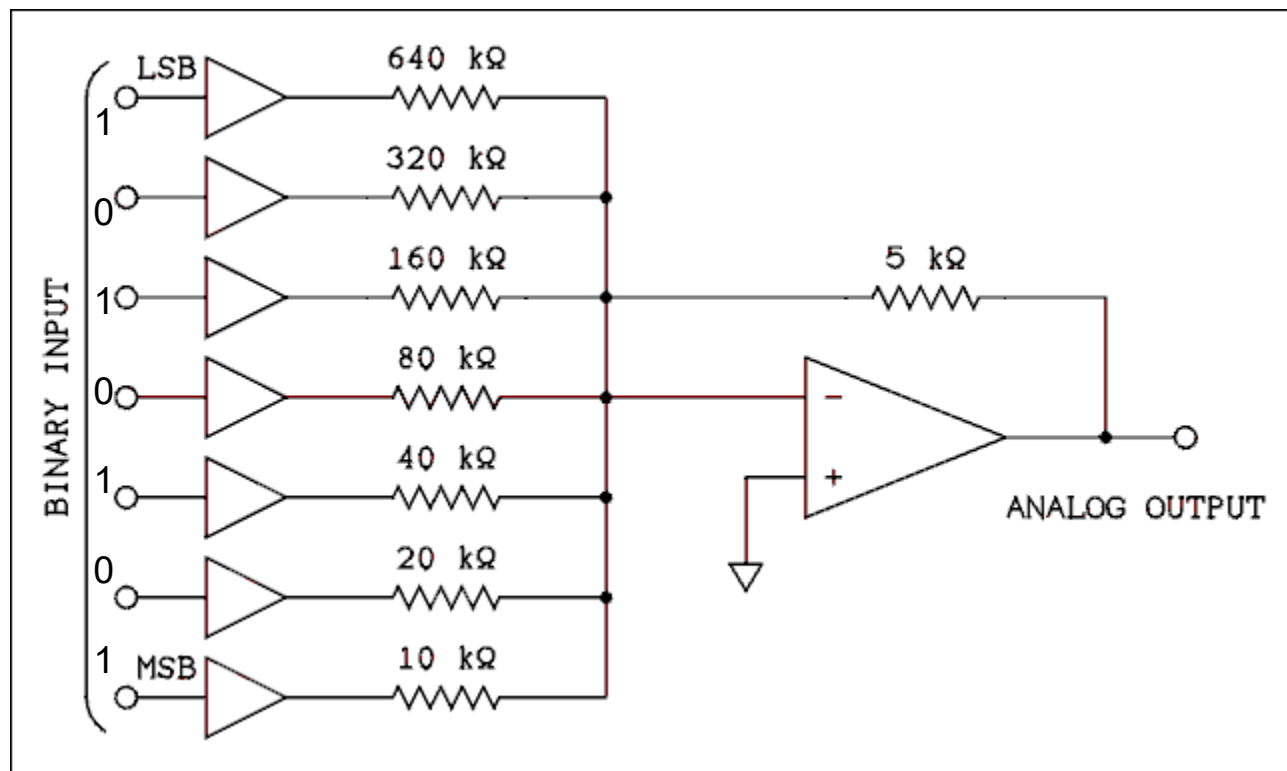

Example of Analogue Comparator ...

- ▶ Analogue Comparator is a device which outputs:
 - ▶ logic 1 if $V(+)$ > $V(-)$
 - ▶ logic 0 if $V(+)$ < $V(-)$

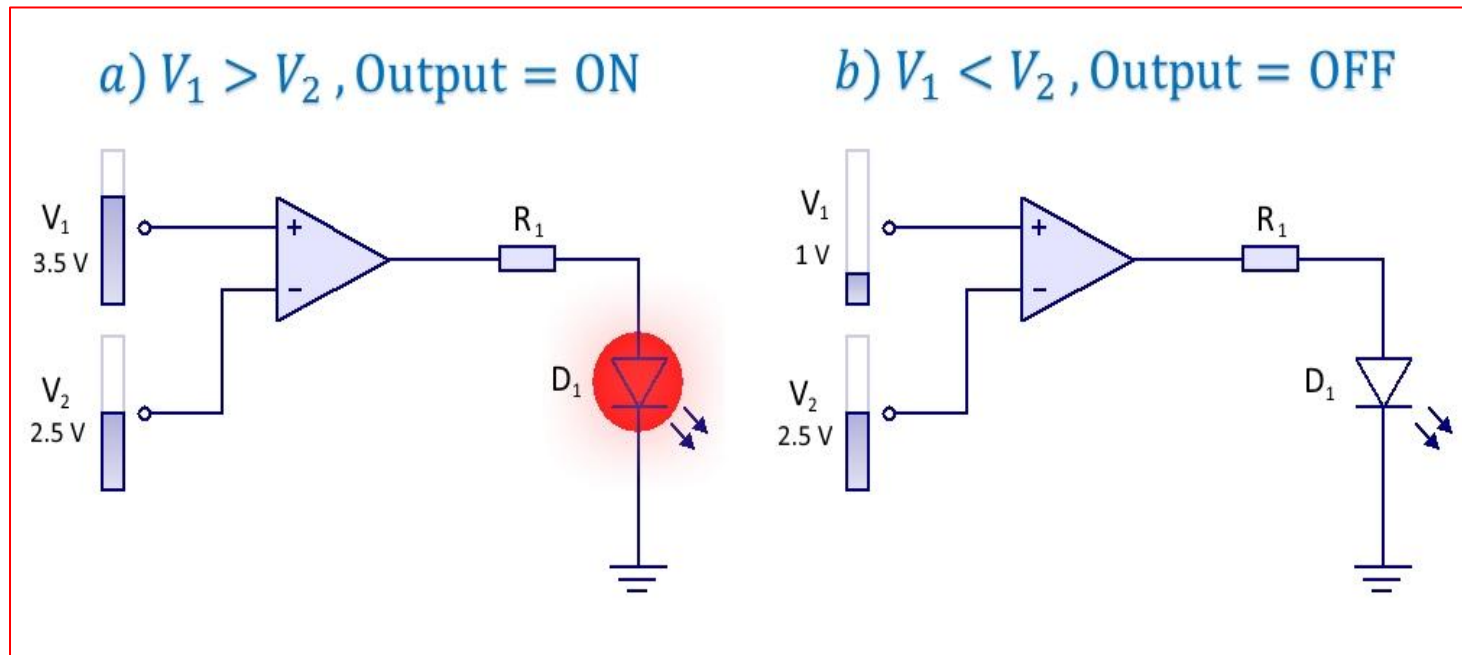

Good News: All microcontrollers are actually digital voltmeters!!!

▶ Cortex M Series

- ▶ Support 12 inputs of voltages under measurement
- ▶ Digital values with 12 bits

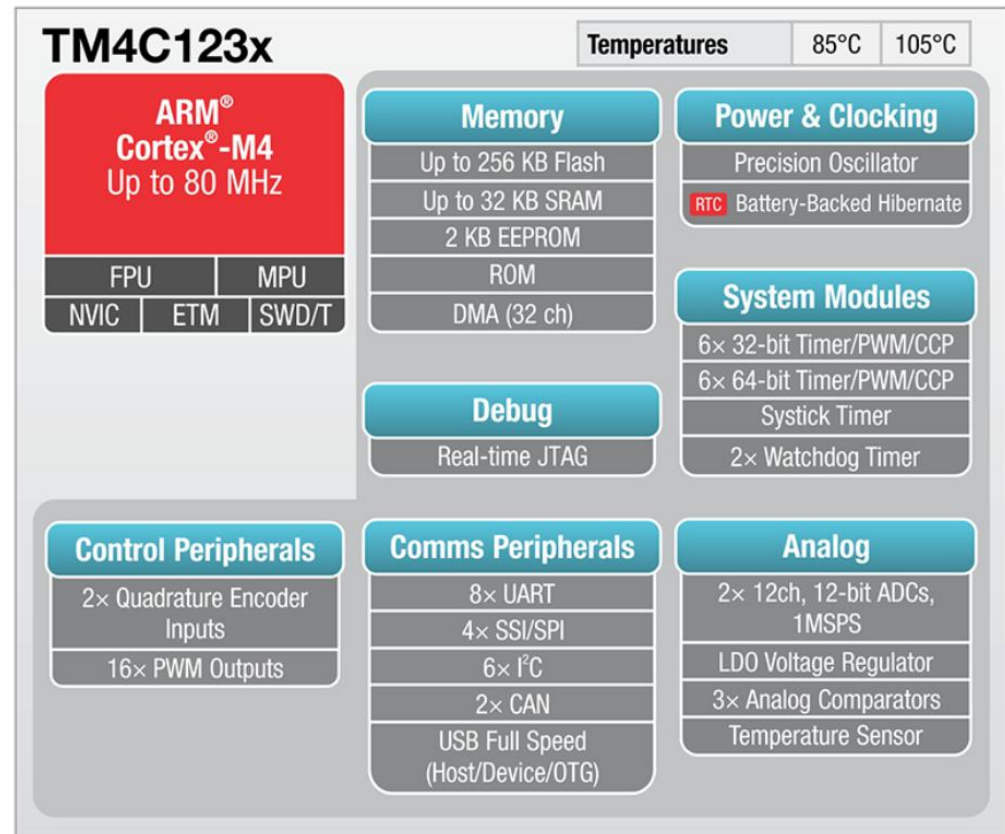

Output from Cortex M4's ADC

- ▶ 12-bit digital numbers: 0x000 to 0xFFF

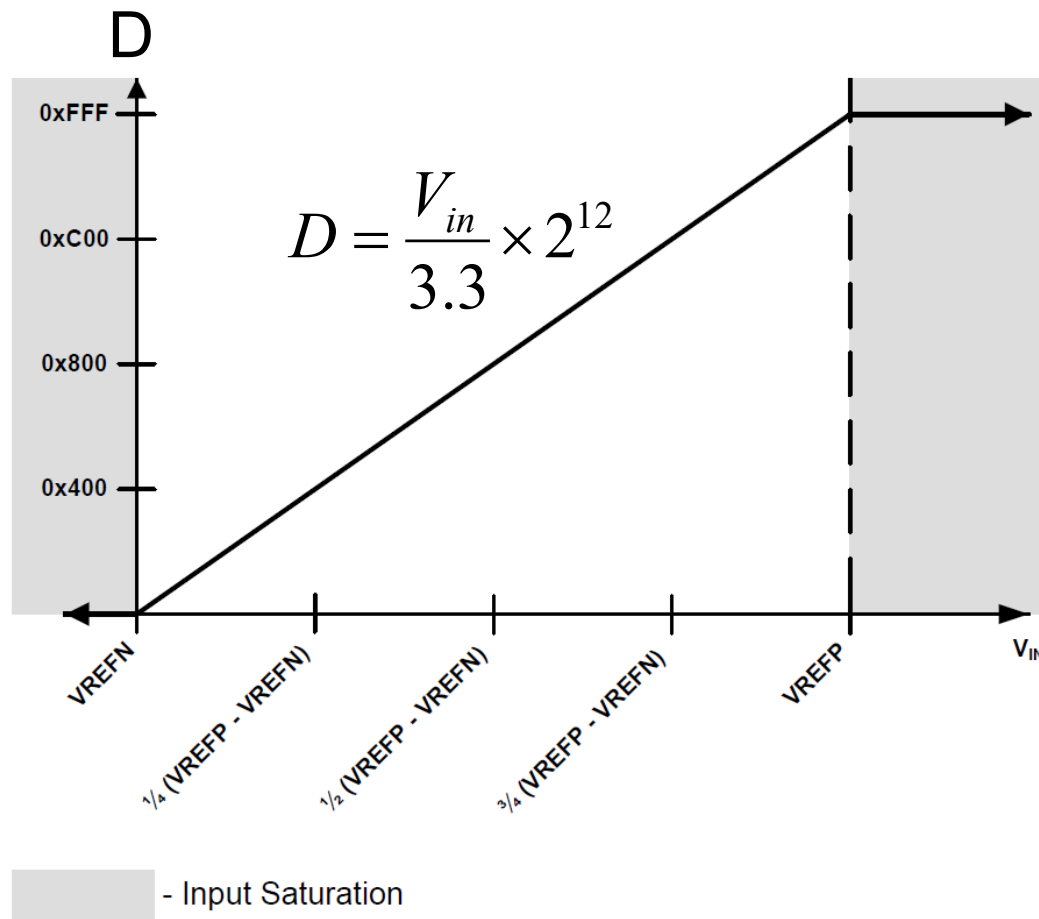

Blueprint of ARM Cortex M4's ADC

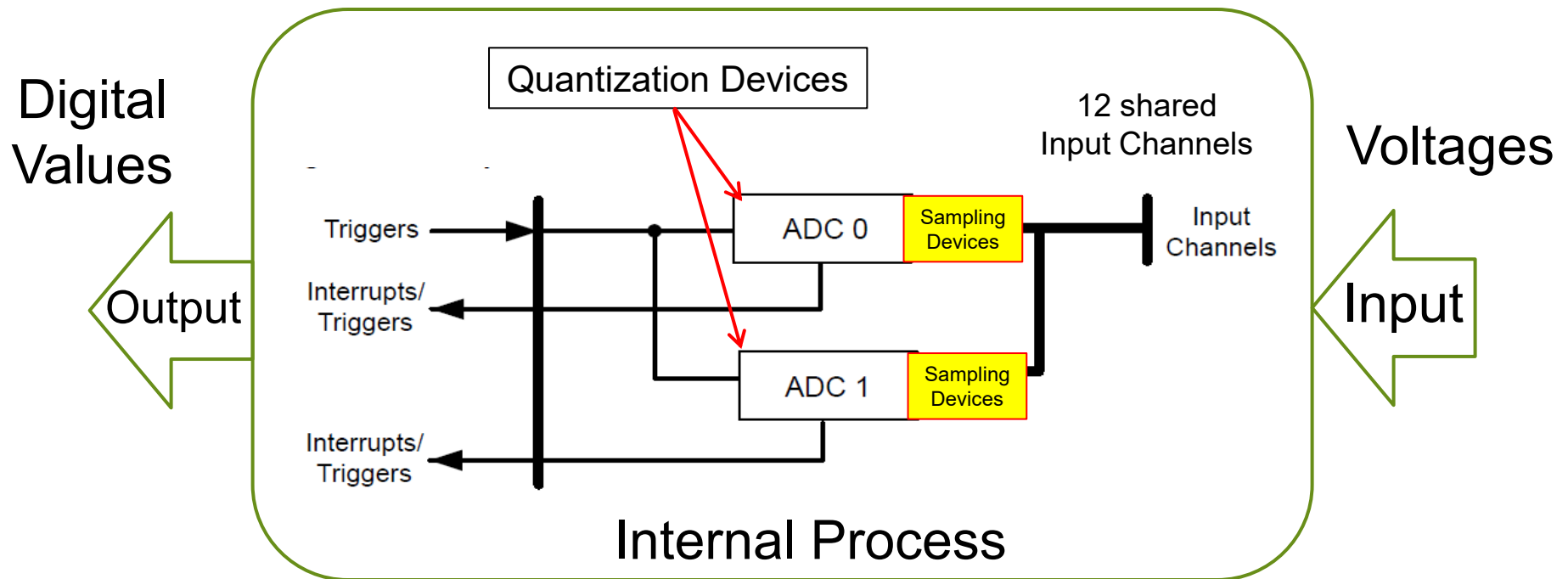

SS0 can take in a sequence of 8 samples.

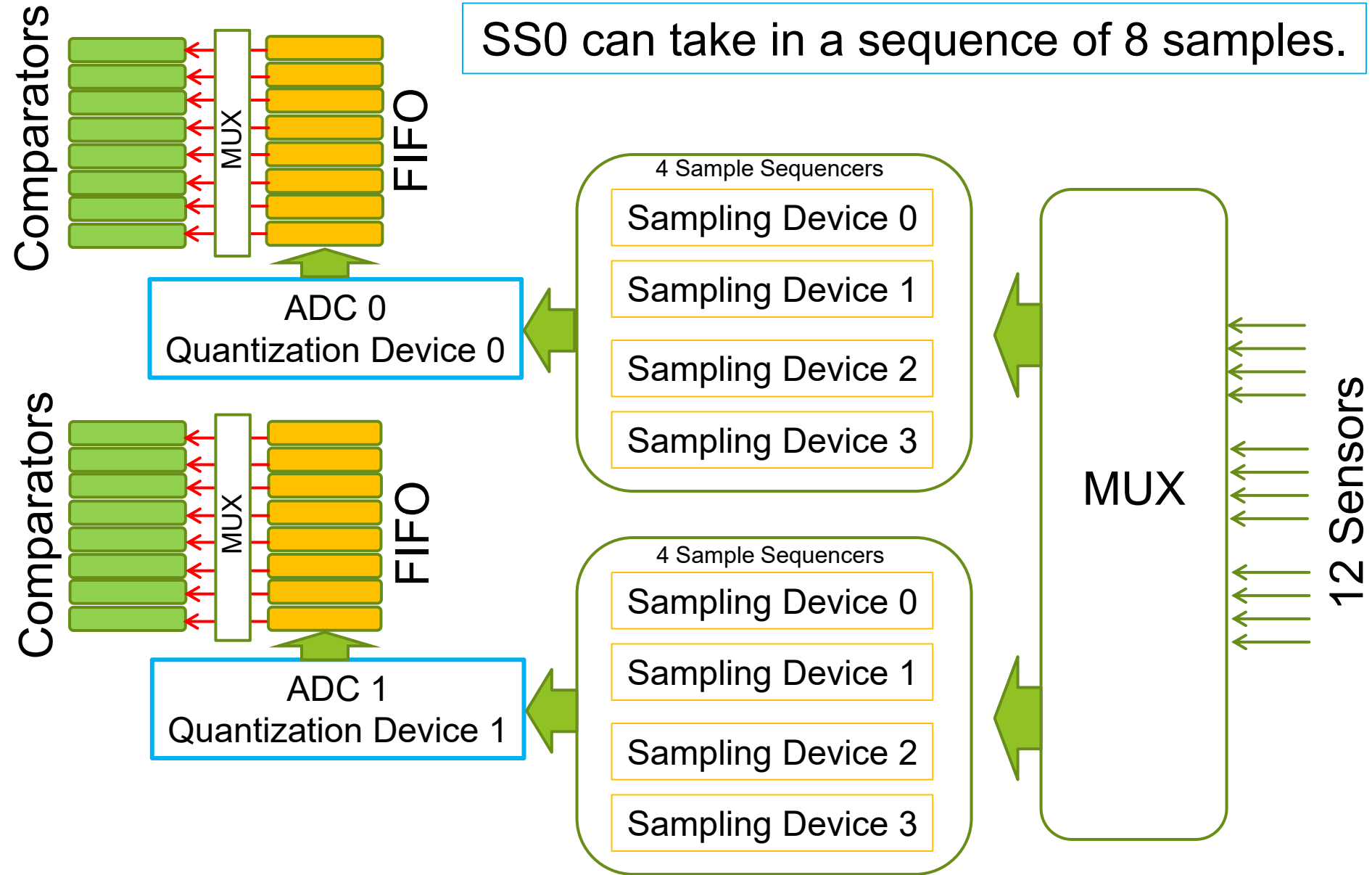

ADC of Sequence-based Approach

The TM4C123GH6PM ADC collects sample data by using a programmable sequence-based approach, instead of the traditional single or double-sampling approaches found on many ADC modules. Each sample sequence is a Fully programmed series of consecutive(back-to-back) samples.

Sample Sequencers

The sampling control and data capture is handled by the sample sequencers. All of the sequencers are identical in implementation except for the number of samples that can be captured and the depth of the FIFO. Table 13-2 on page 802 shows the maximum number of samples that each sequencer can capture and its corresponding FIFO depth. Each sample that is captured is stored in the FIFO. In this implementation, each FIFO entry is a 32-bit word, with the lower 12 bits containing the conversion result.

Table 13-2. Samples and FIFO Depth of Sequencers

Sequencer	Number of Samples	Depth of FIFO
SS3	1	1
SS2	4	4
SS1	4	4
SS0	8	8

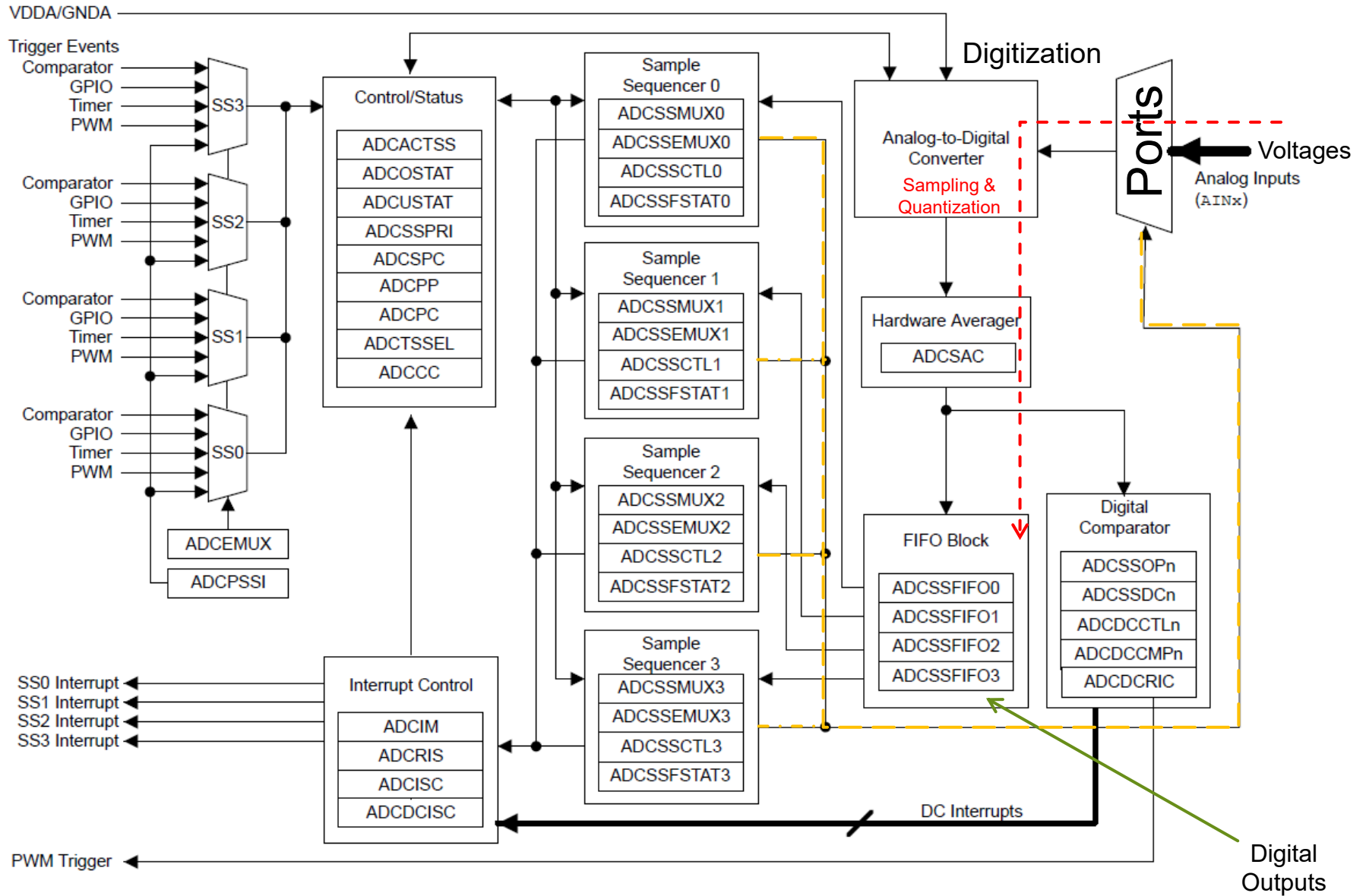
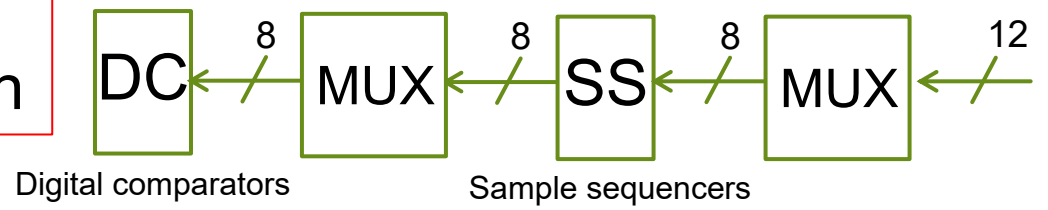

Table of ADC's Input Pins (12 in total)

Pin Name	Pin Number	Pin Mux / Pin Assignment	Pin Type	Buffer Type ^a	Description
AIN0	6	PE3	I	Analog	Analog-to-digital converter input 0.
AIN1	7	PE2	I	Analog	Analog-to-digital converter input 1.
AIN2	8	PE1	I	Analog	Analog-to-digital converter input 2.
AIN3	9	PE0	I	Analog	Analog-to-digital converter input 3.
AIN4	64	PD3	I	Analog	Analog-to-digital converter input 4.
AIN5	63	PD2	I	Analog	Analog-to-digital converter input 5.
AIN6	62	PD1	I	Analog	Analog-to-digital converter input 6.
AIN7	61	PD0	I	Analog	Analog-to-digital converter input 7.
AIN8	60	PE5	I	Analog	Analog-to-digital converter input 8.

Pin Name	Pin Number	Pin Mux / Pin Assignment	Pin Type	Buffer Type ^a	Description
AIN9	59	PE4	I	Analog	Analog-to-digital converter input 9.
AIN10	58	PB4	I	Analog	Analog-to-digital converter input 10.
AIN11	57	PB5	I	Analog	Analog-to-digital converter input 11.

Sample sequencer 0 can take 8 analogue inputs/scan



About Differential Sampling

Differential Sampling

In addition to traditional single-ended sampling, the ADC module supports differential sampling of two analog input channels. To enable differential sampling, software must set the D_n bit in the **ADCSSCTL0n** register in a step's configuration nibble.

When a sequence step is configured for differential sampling, the input pair to sample must be configured in the **ADCSSMUXn** register. Differential pair 0 samples analog inputs 0 and 1; differential pair 1 samples analog inputs 2 and 3; and so on (see Table 13-3 on page 810). The ADC does not support other differential pairings such as analog input 0 with analog input 3.

Table 13-3. Differential Sampling Pairs

Differential Pair	Analog Inputs
0	0 and 1
1	2 and 3
2	4 and 5
3	6 and 7
4	8 and 9
5	10 and 11

Application of Differential Sampling

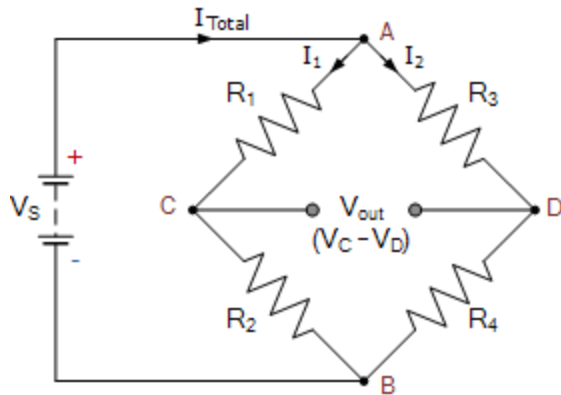

Wheatstone Bridge Circuit

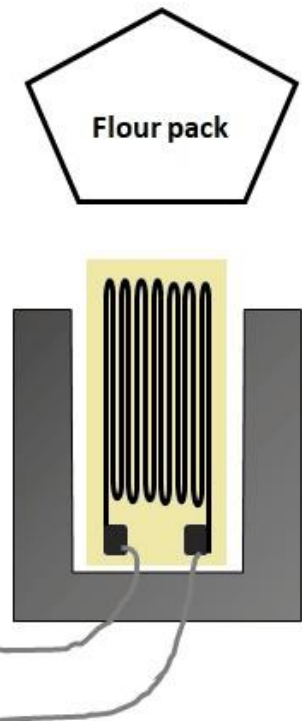
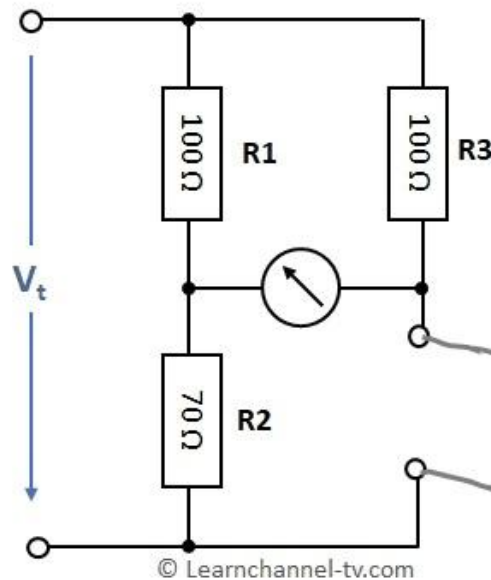

Why to calibrate a sensor?

- ▶ Reason:
 - ▶ Measured values may not be equal to true values.

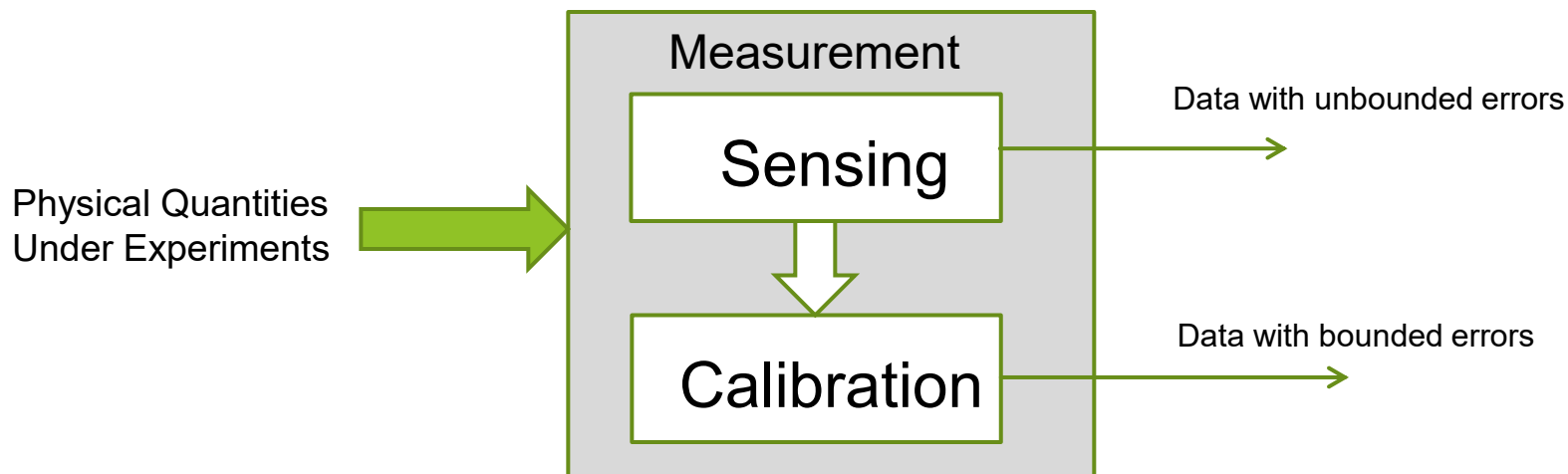

How to obtain reference values for sensor calibration?

- ▶ Standard of 1 Volt:
 - ▶ It is equal to the potential difference between two parallel, infinite planes spaced 1 meter apart that create an electric field of 1 newton per coulomb.

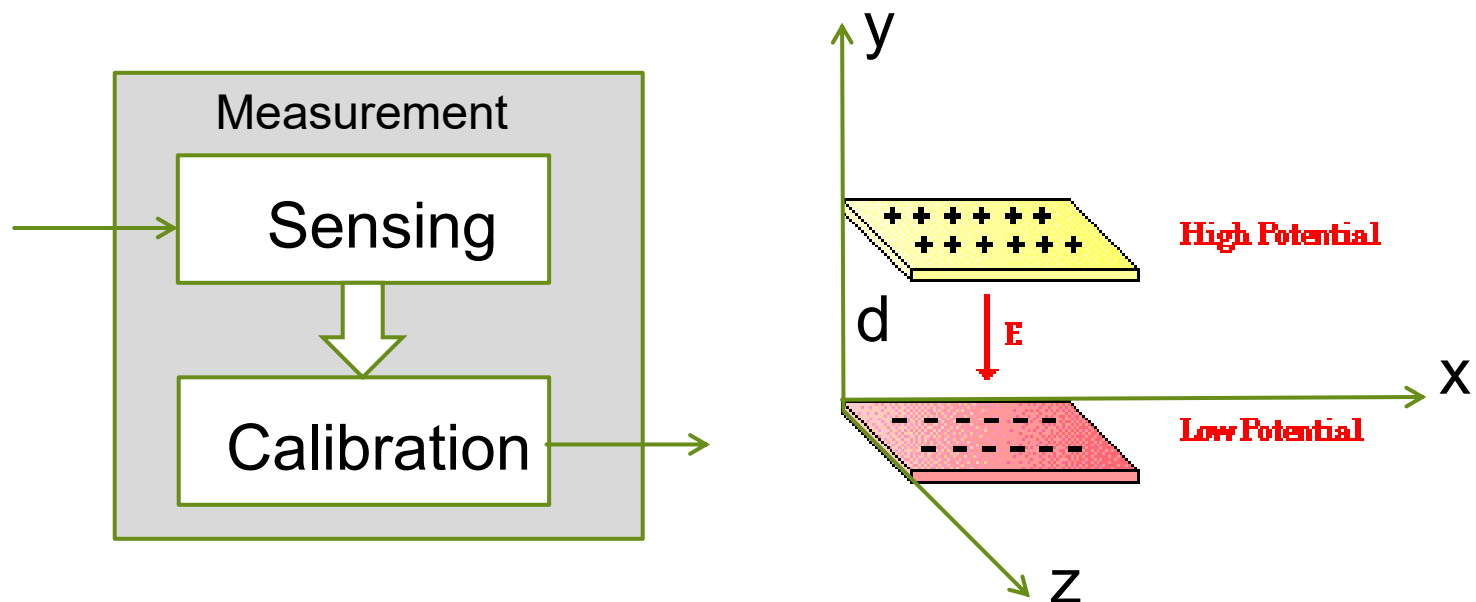

How to do sensor calibration?

- ▶ To prepare reference values as inputs.
- ▶ To read sensory outputs corresponding to reference values at input.
- ▶ To determine the equation which makes measured values to be equal to reference values.

Measured Values

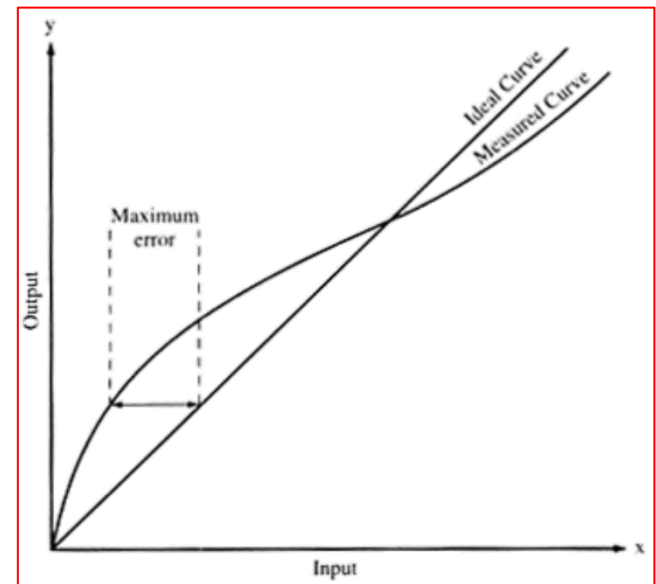
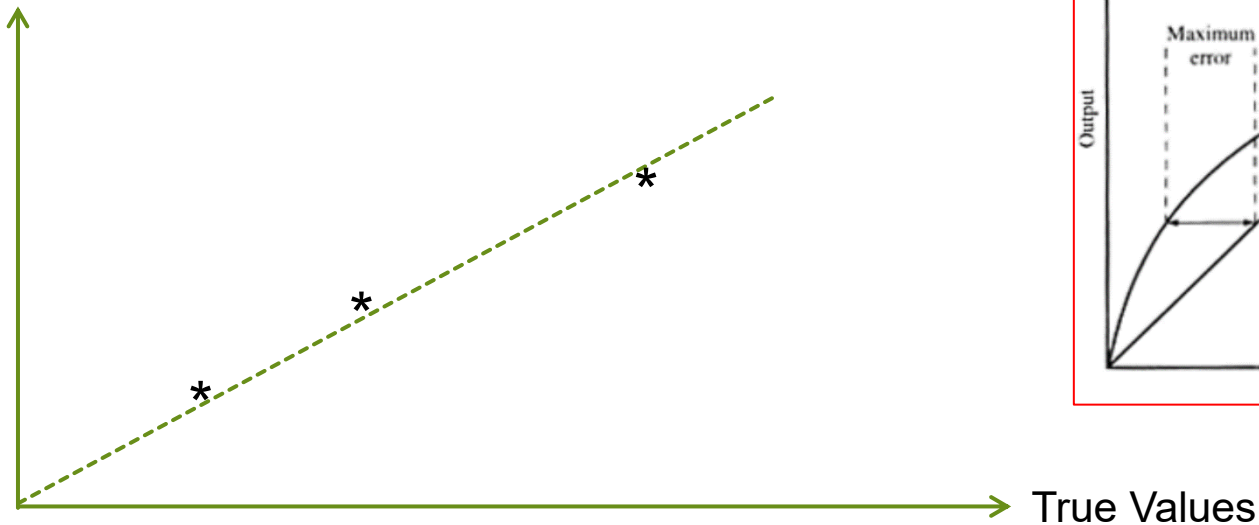

Exercise

- A voltmeter has a built calibration unit as shown in the figure below. The measurement range is between 0.0 Volts and 5.0 Volts. During a calibration test, the values of output Y_i from the sensing unit are 1.2, 2.3, 3.4, 4.5 and 5.6 when the true values of input X_i are 1.0, 2.0, 3.0, 4.0 and 5.0, respectively. What should be the equations for us to determine the coefficients inside the following calibration equation: $Z_i = a_4 Y_i^4 + a_3 Y_i^3 + a_2 Y_i^2 + a_1 Y_i + a_0$?

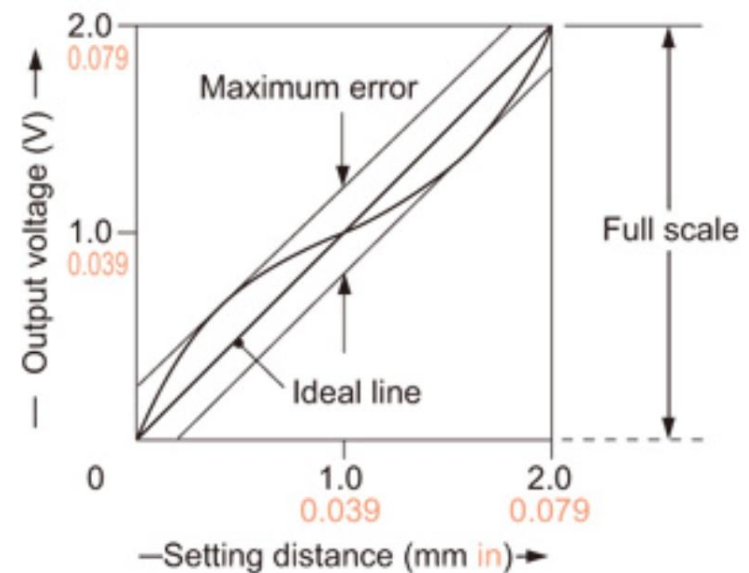
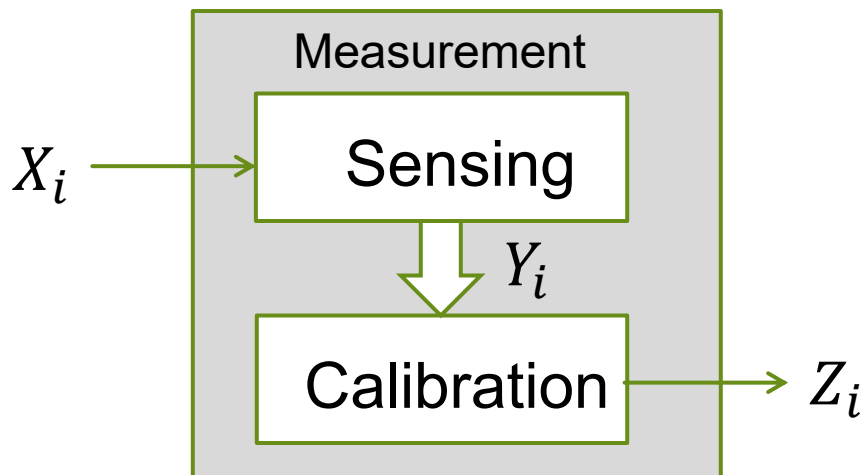

Answer:

$$Z_i = a_4 Y_i^4 + a_3 Y_i^3 + a_2 Y_i^2 + a_1 Y_i + a_0$$

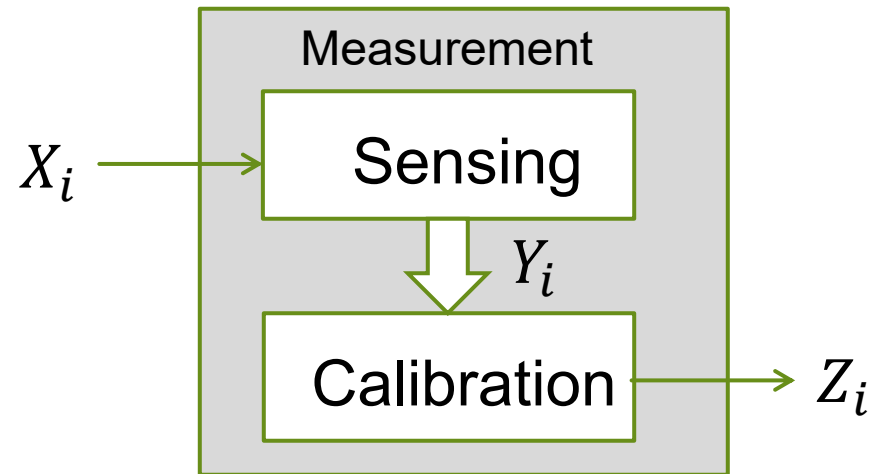

$$1.0 = a_4 \times 1.2^4 + a_3 \times 1.2^3 + a_2 \times 1.2^2 + a_1 \times 1.2 + a_0$$

$$2.0 = a_4 \times 2.3^4 + a_3 \times 2.3^3 + a_2 \times 2.3^2 + a_1 \times 2.3 + a_0$$

$$3.0 = a_4 \times 3.4^4 + a_3 \times 3.4^3 + a_2 \times 3.4^2 + a_1 \times 3.4 + a_0$$

$$4.0 = a_4 \times 4.5^4 + a_3 \times 4.5^3 + a_2 \times 4.5^2 + a_1 \times 4.5 + a_0$$

$$5.0 = a_4 \times 5.6^4 + a_3 \times 5.6^3 + a_2 \times 5.6^2 + a_1 \times 5.6 + a_0$$

$Z_i = X_i$	Y_i
1.0	1.2
2.0	2.3
3.0	3.4
4.0	4.5
5.0	5.6

Why to do sensor's error analysis?

- ▶ Reason: To tell buyers or users about a sensor's performance.
- ▶ Error analysis is to compute:
 - ▶ Systematic error = mean value - true value
 - ▶ Repeatability error = value with maximum error - mean value
 - ▶ Accuracy = value with minimum error - mean value
 - ▶ Hysteresis error = |measured value in increasing - measured value in decreasing|

For each true value, we can do error analysis

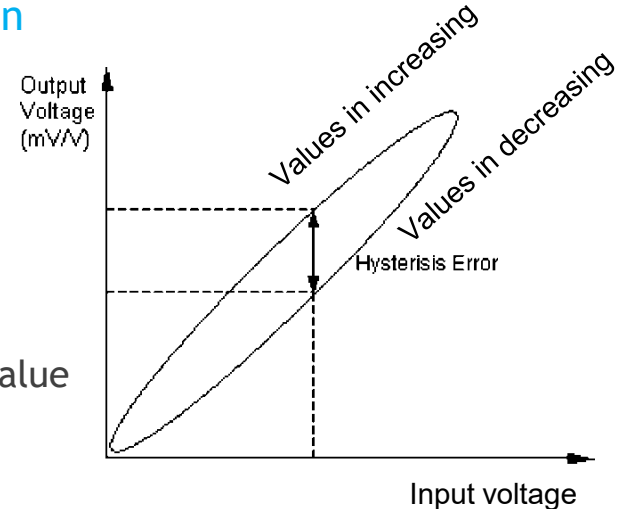
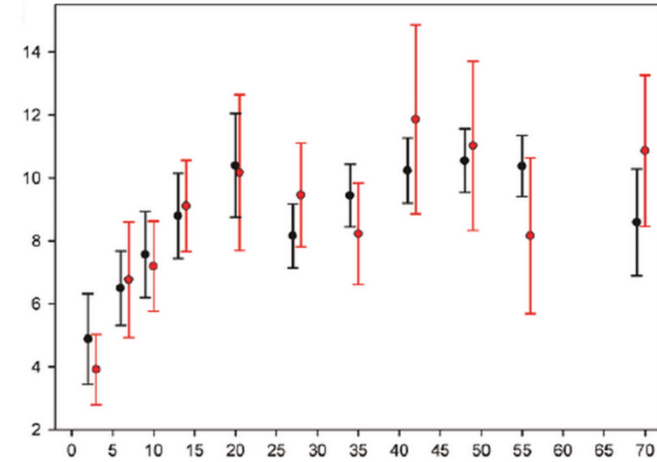

Example

- ▶ In a calibration test, 10 measurements using a digital voltmeter have been made of the voltage of a battery that is known to have a true voltage of 6.11 Volts. The readings are: 5.98, 6.05, 6.10, 6.06, 5.99, 5.96, 6.02, 6.09, 6.03, and 5.99 Volts. What is the systematic error? And, what is the repeatability error?

- ▶ Answer:

- ▶ Mean value of measurements is:
 - ▶ $V_{\text{aver}} = 6.03$ volts
- ▶ Systematic error is:
 - ▶ $V_{\text{aver}} - V_{\text{true}} = 6.03 - 6.11 = -0.08$ volts
- ▶ Repeatability error is:
 - ▶ $V_{\text{max}} - V_{\text{mean}} = 5.96 - 6.03 = -0.07$ volts

For each true value, we can do error analysis

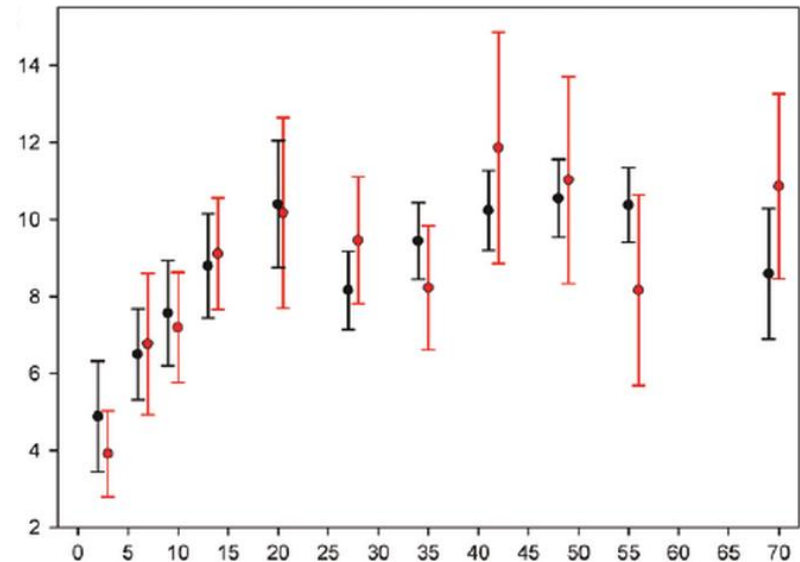

Summary

- ▶ Electrical Charge
- ▶ Electrical Force
- ▶ Electrical Field
- ▶ Electrical Potential
- ▶ Measurement of Voltage

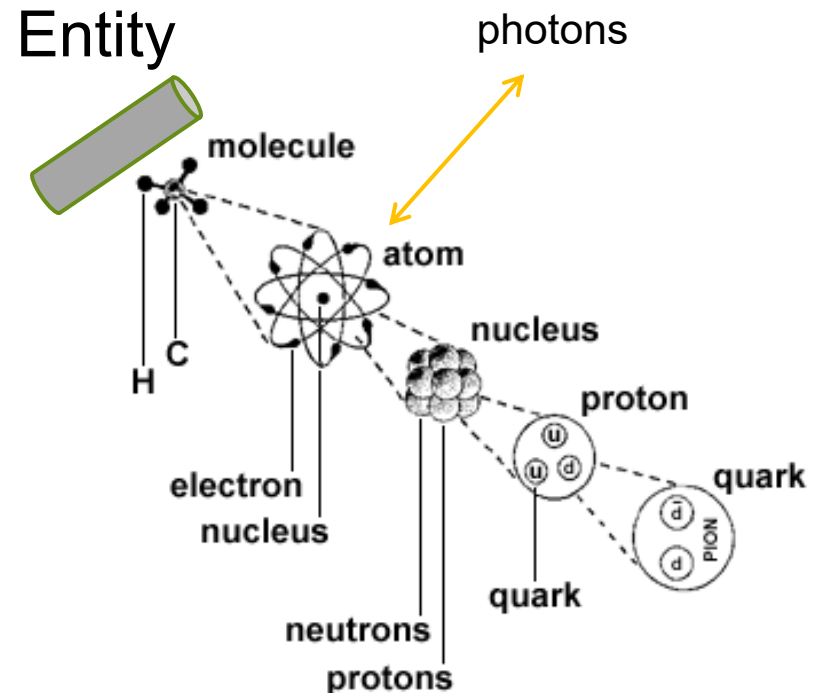
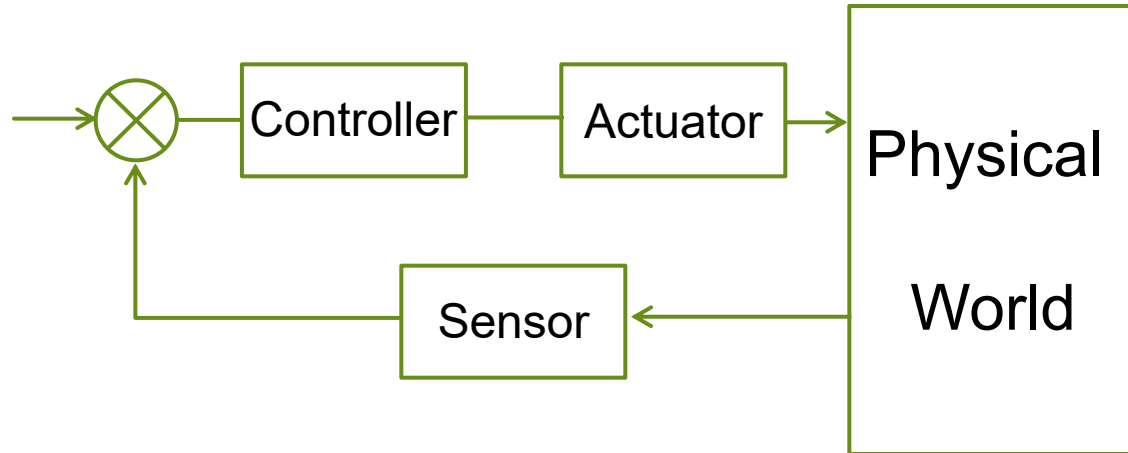

Outline of Module 2

- ▶ Lecture 1:
 - ▶ Measurement of Voltage
- ▶ Lecture 2:
 - ▶ Measurement of Current
- ▶ Lecture 3:
 - ▶ Measurement of Resistance
- ▶ Lecture 4:
 - ▶ Measurement of Capacitance
- ▶ Lecture 5:
 - ▶ Measurement of Inductance

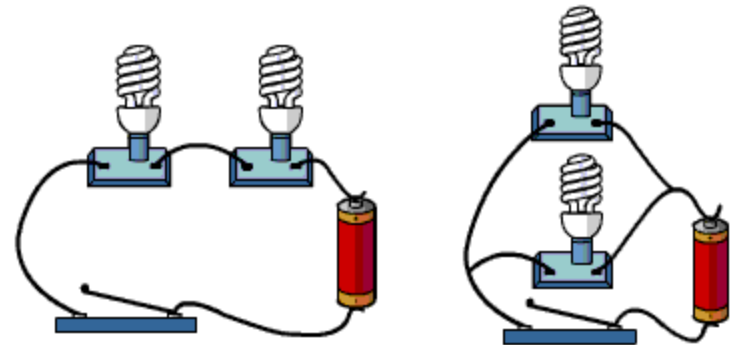

Series Circuit

Parallel Circuit

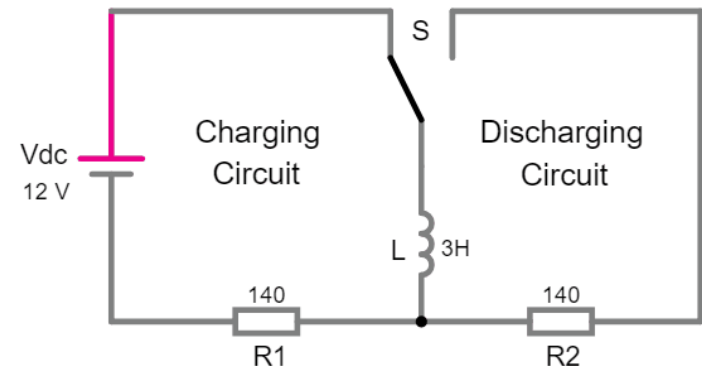
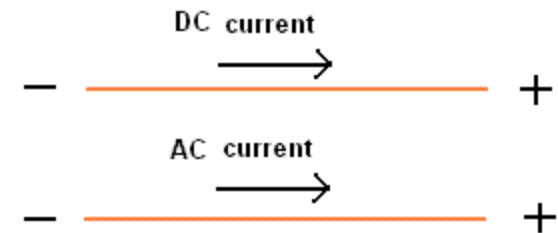



NANYANG
TECHNOLOGICAL
UNIVERSITY

School of Mechanical & Aerospace Engineering

Design, Machine, Control, Intelligence

Module 2 Lecture 2

MA4822

Measurement of Current

Xie Ming, PhD (France)

mmxie@ntu.edu.sg

<http://personal.ntu.edu.sg/mmxie>

Outline

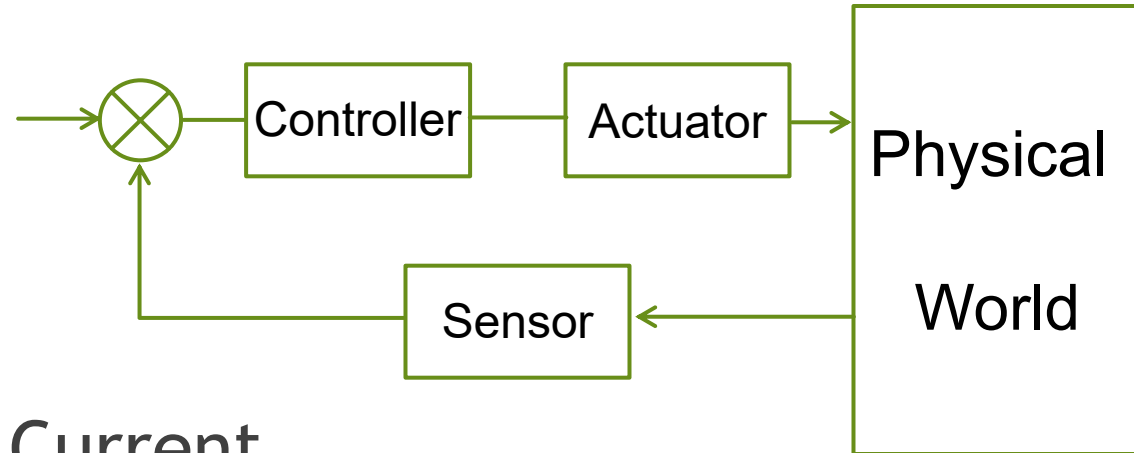

► Understanding of Current

► Computation of Current

► Measurement of Current

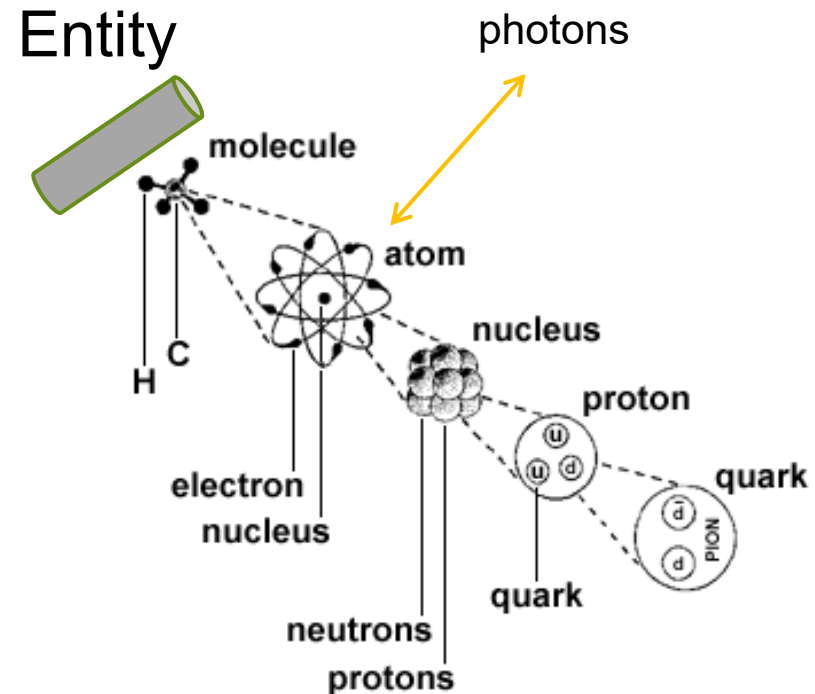

Outline

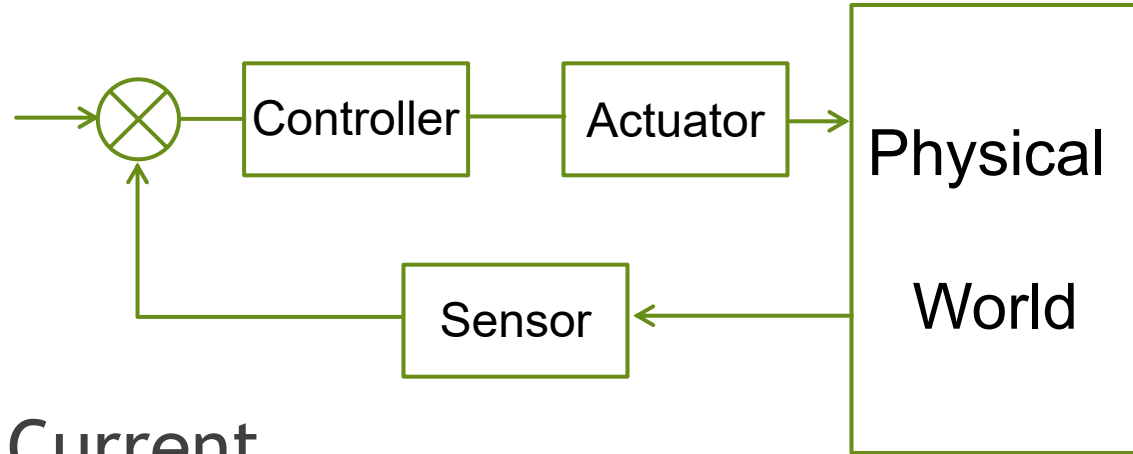

► Understanding of Current

► Computation of Current

► Measurement of Current

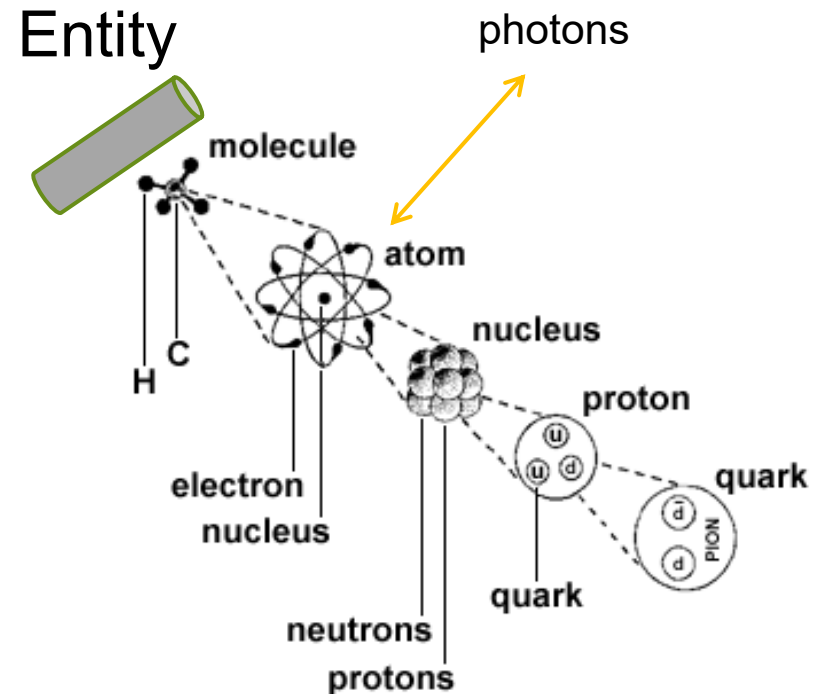

Understanding Current (1)

- An atom can be in one of the following states:

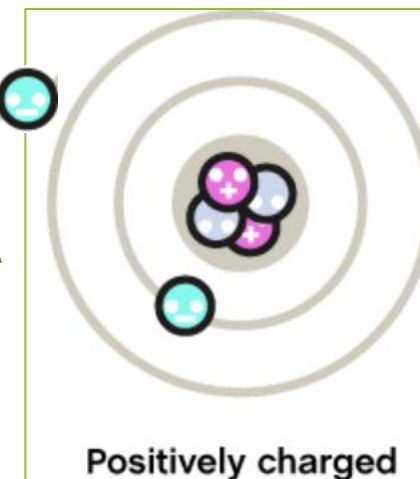
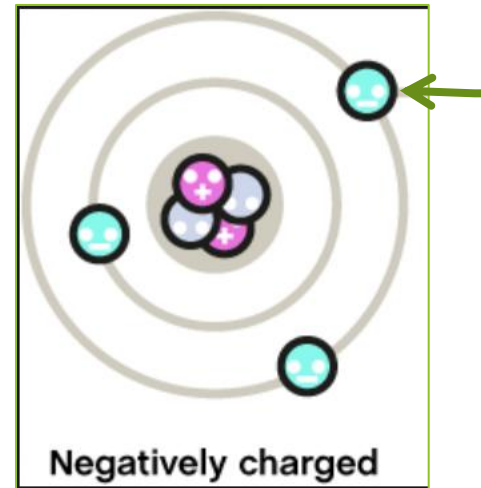
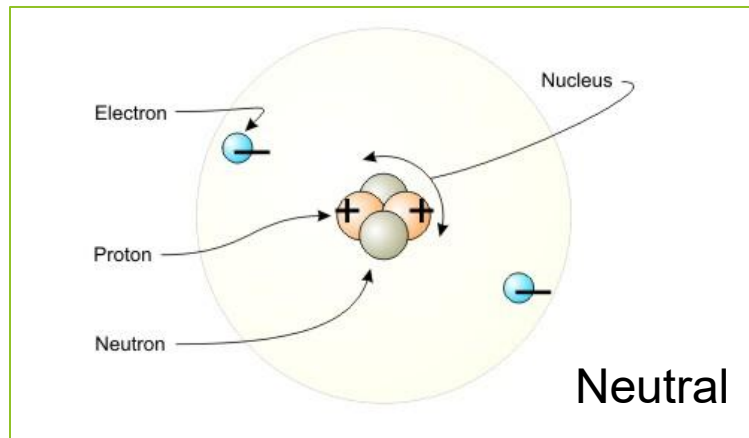

Understanding Current (2)

- ▶ The flow of negative charges (i.e. electrons) in one direction gives rise to the impression of a flow of positive charges (or **current**) in the opposite direction.

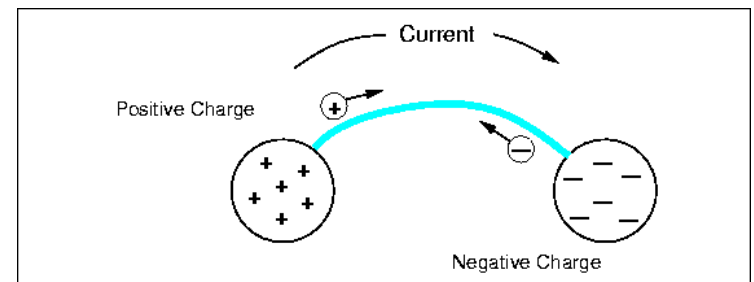
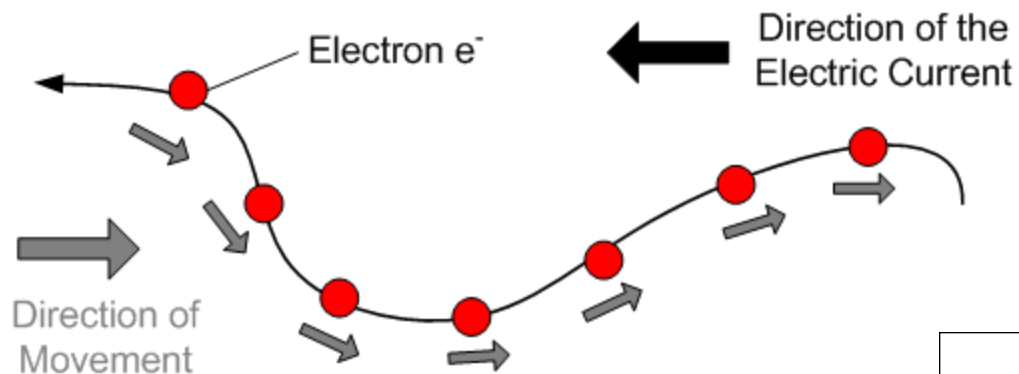

Understanding Current (3)

- ▶ Current is the flow of electrons inside a path which is called conductor.

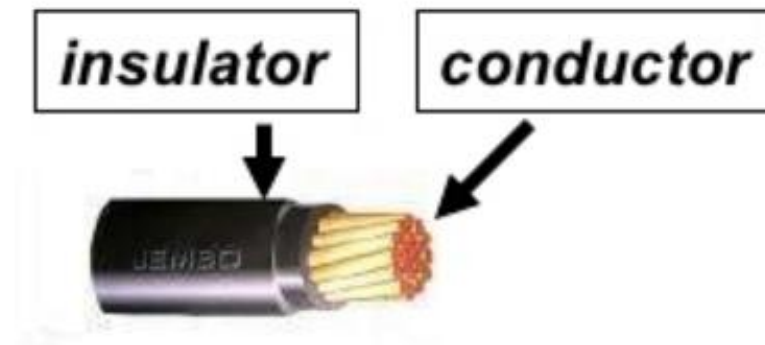

Example

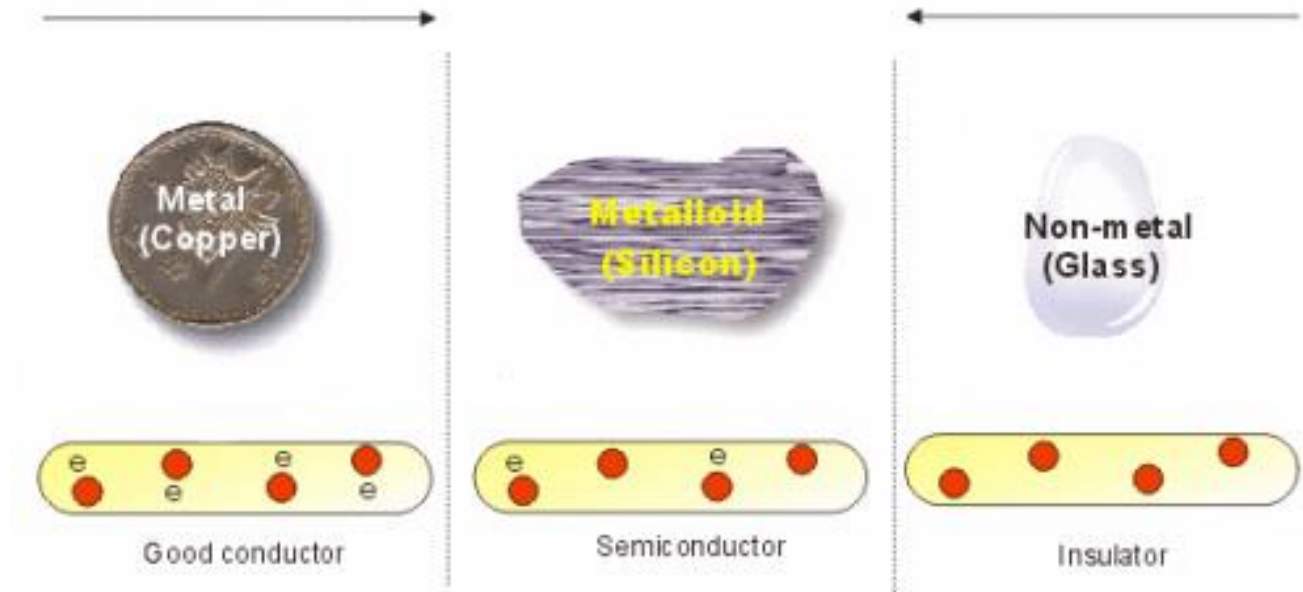

Understanding Current (4)

- ▶ Current cannot flow into insulator.

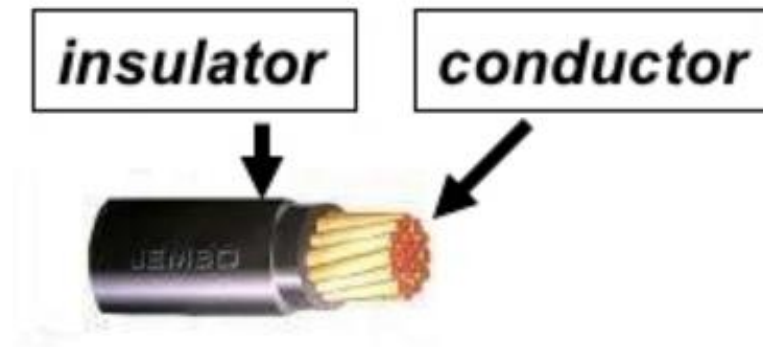

Example

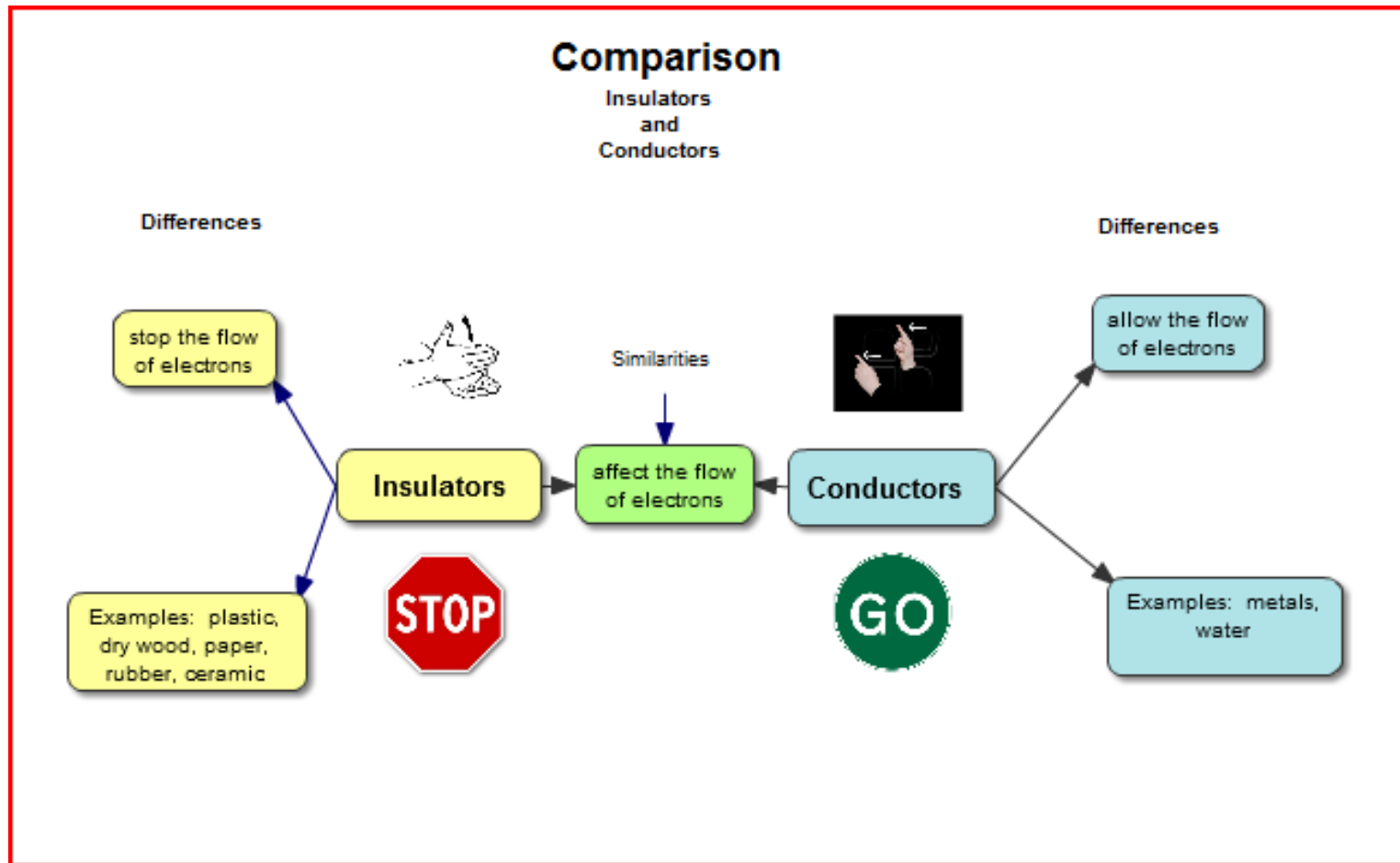

Understanding Current (5)

- ▶ High current corresponds to high density of electrons in a flow. Low current corresponds to low density of electrons in a flow.

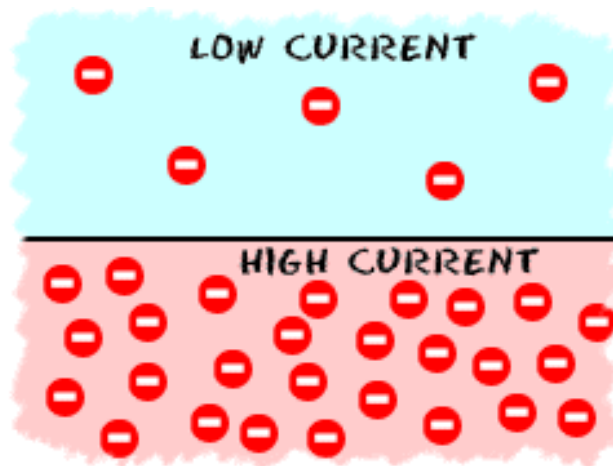

Example

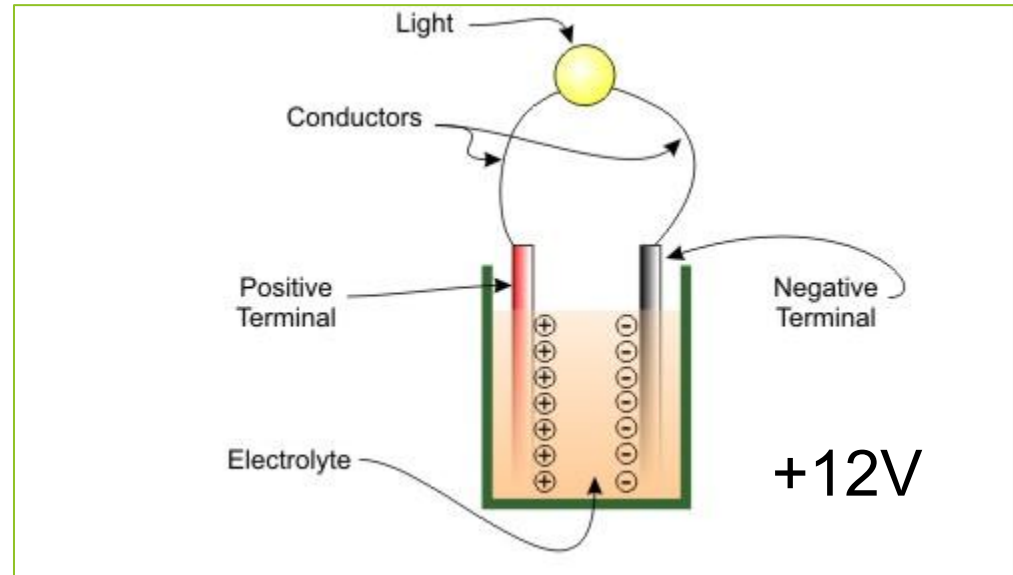
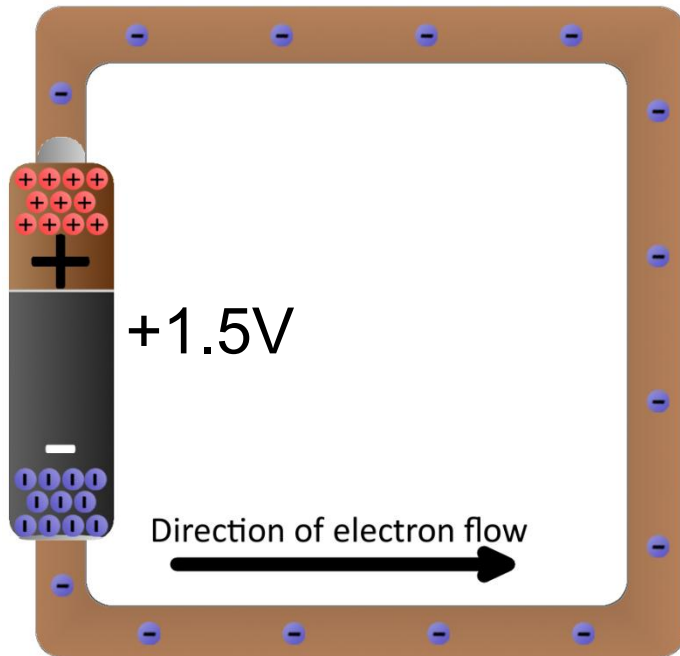

Higher voltage could produce higher current

Understanding Current (6)

- ▶ When a current passes through a coil, it will produce a magnetic field.

$$\frac{V_p}{N_p} = \frac{V_s}{N_s}$$

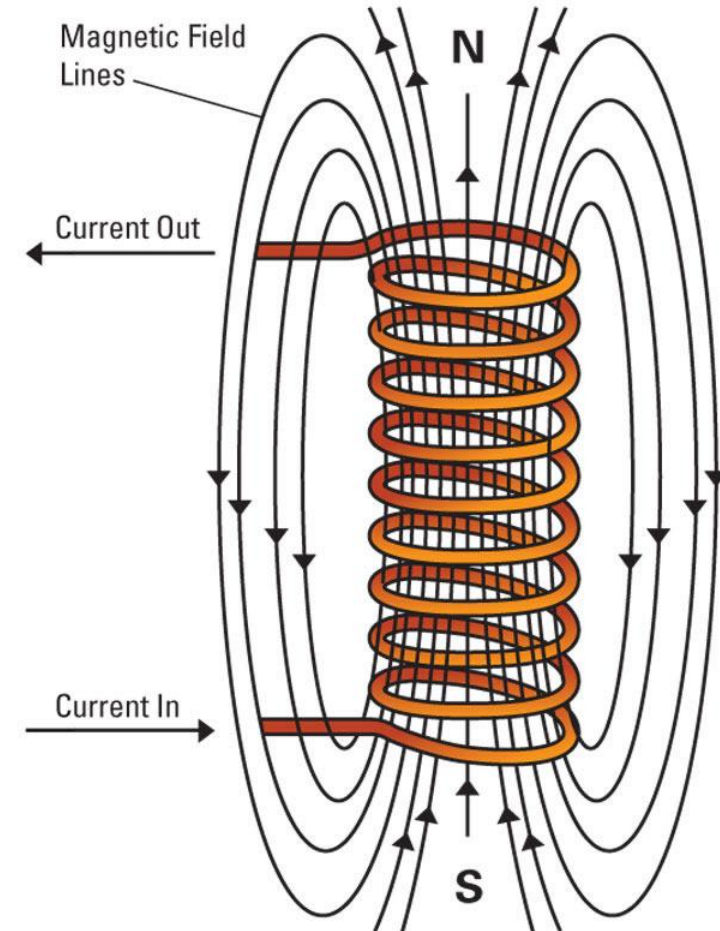
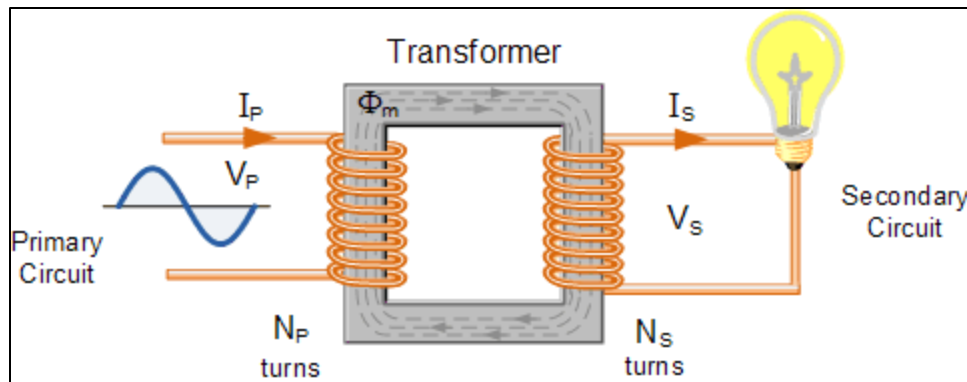

Example of Making Coils

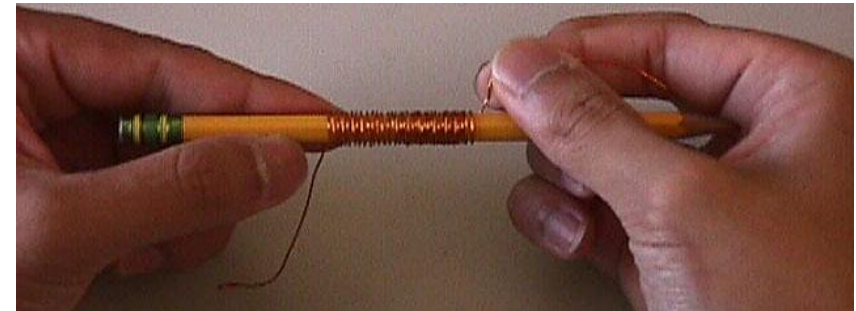
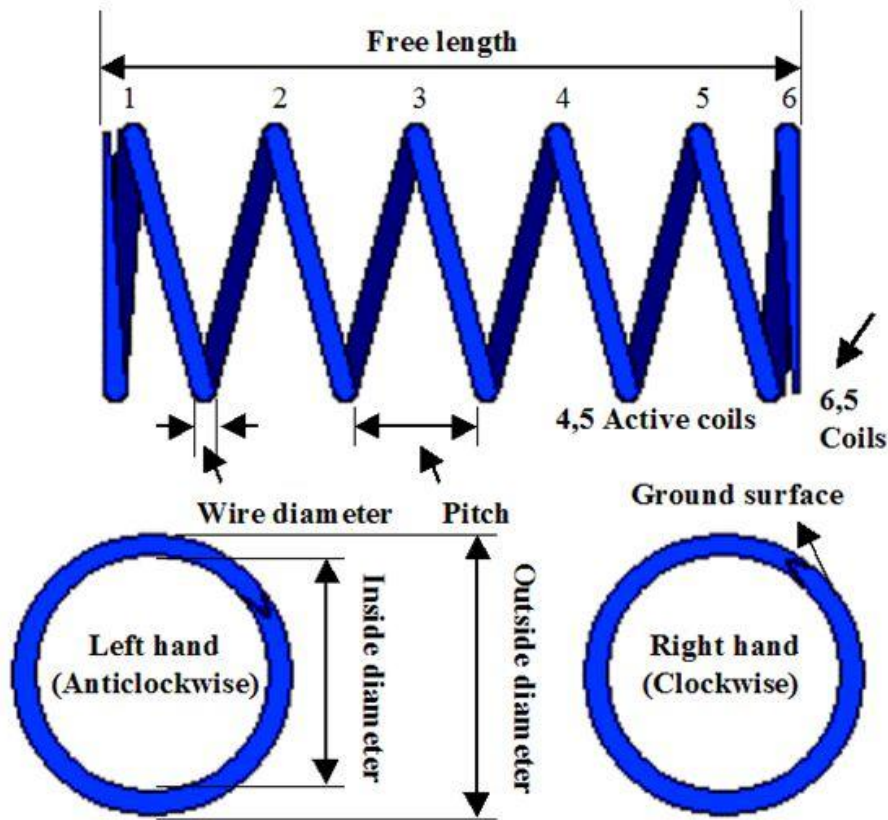

Example of Coils inside Motors

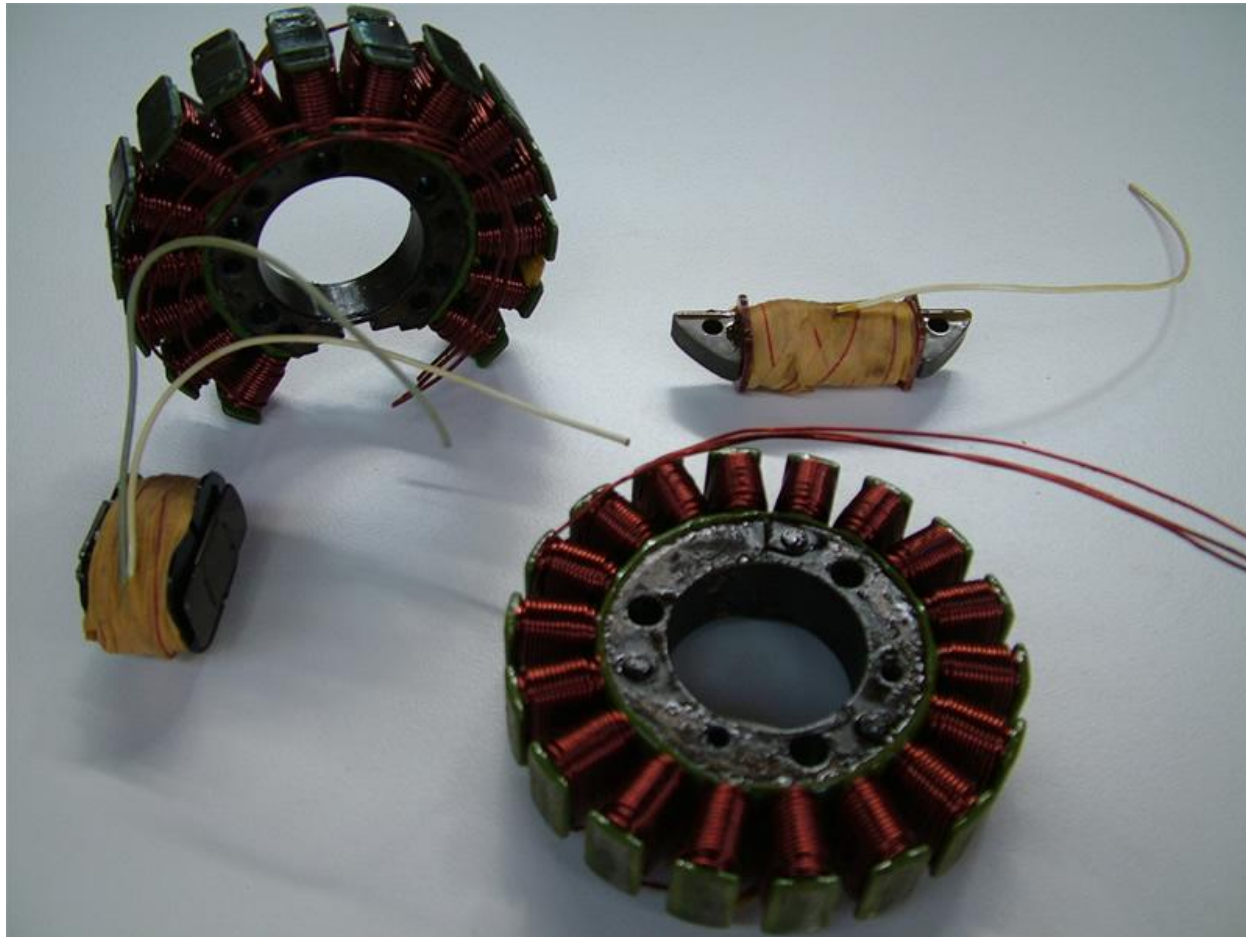

What is a magnetic field?

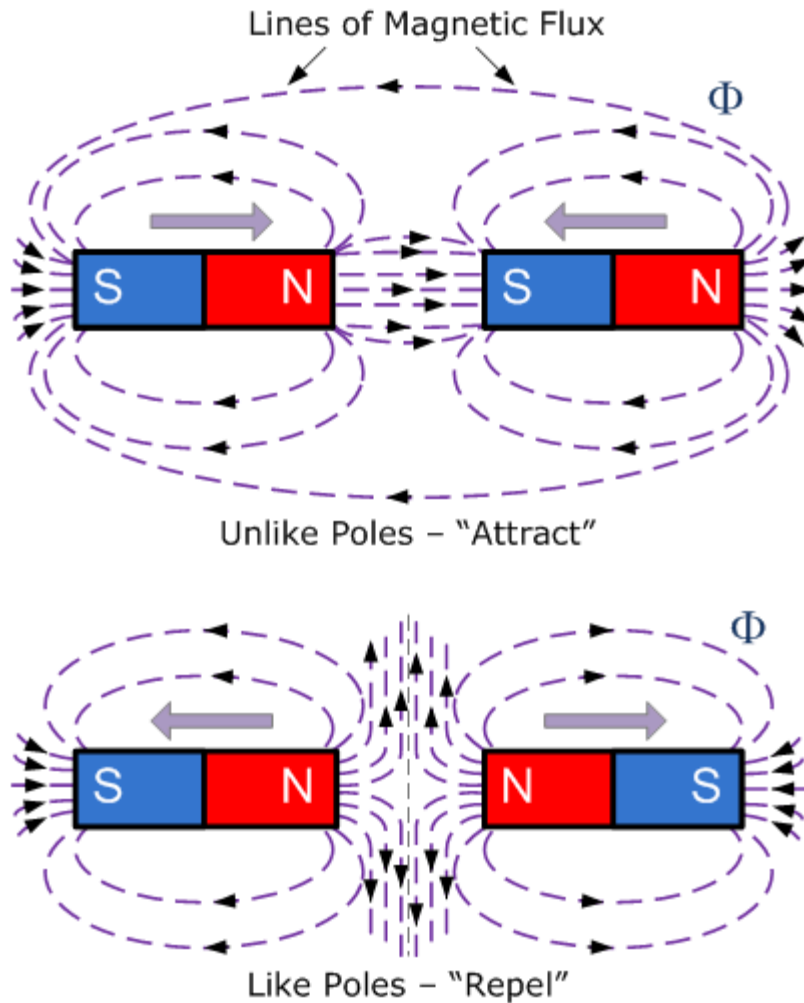

Understanding Current (7)

- ▶ When a current passes through a conductor which is placed inside a magnetic field, there will be an electro-magnetic force acting on the conductor.

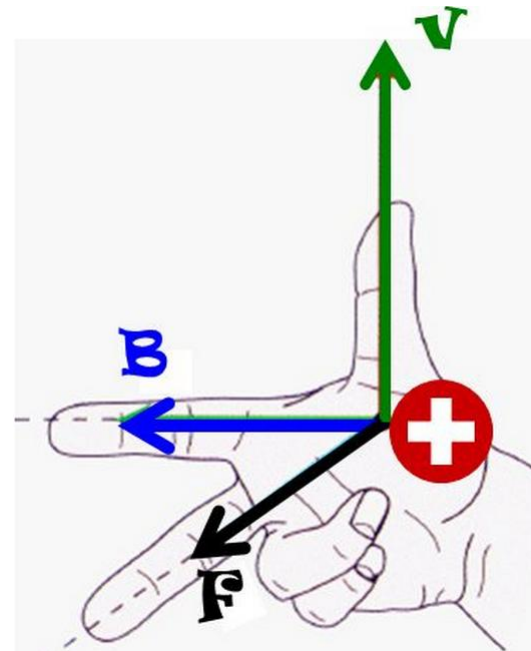
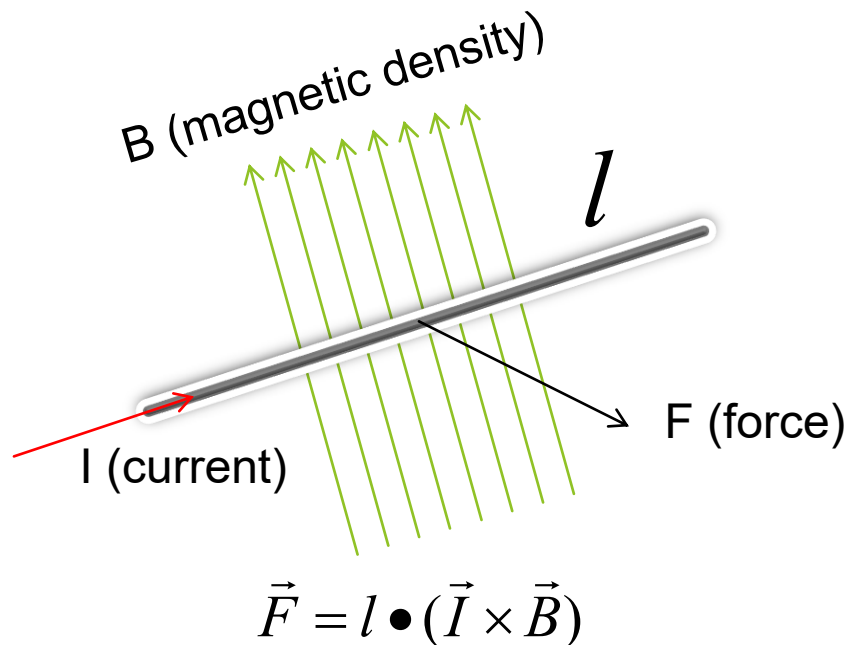

Right-hand Rule

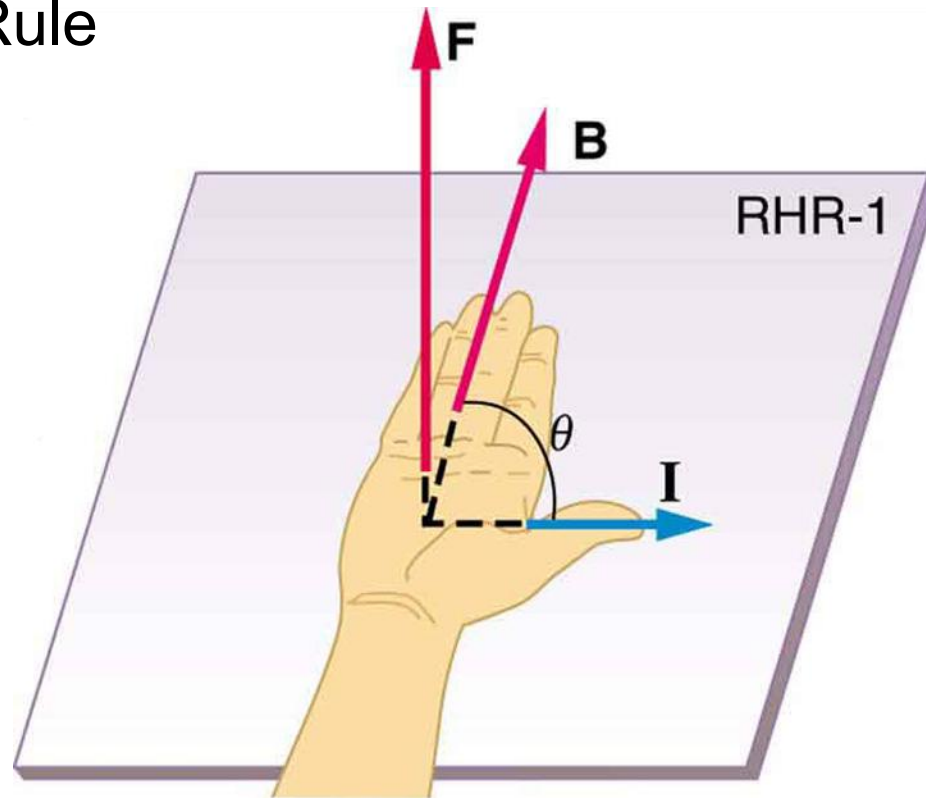

$$F = I\ell B \sin \theta$$

$$\mathbf{F} \perp \text{plane of } \mathbf{I} \text{ and } \mathbf{B}$$

Example of Energy Conversion (Motor)

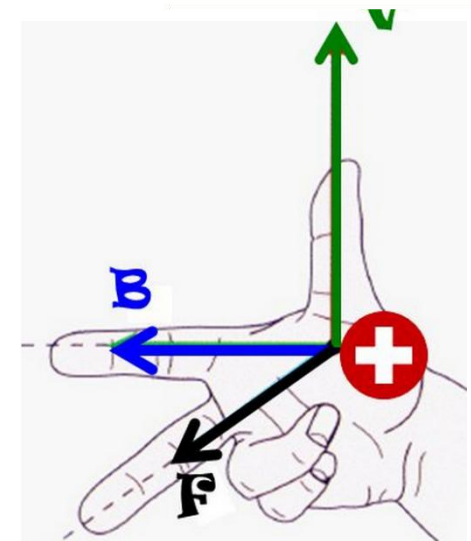
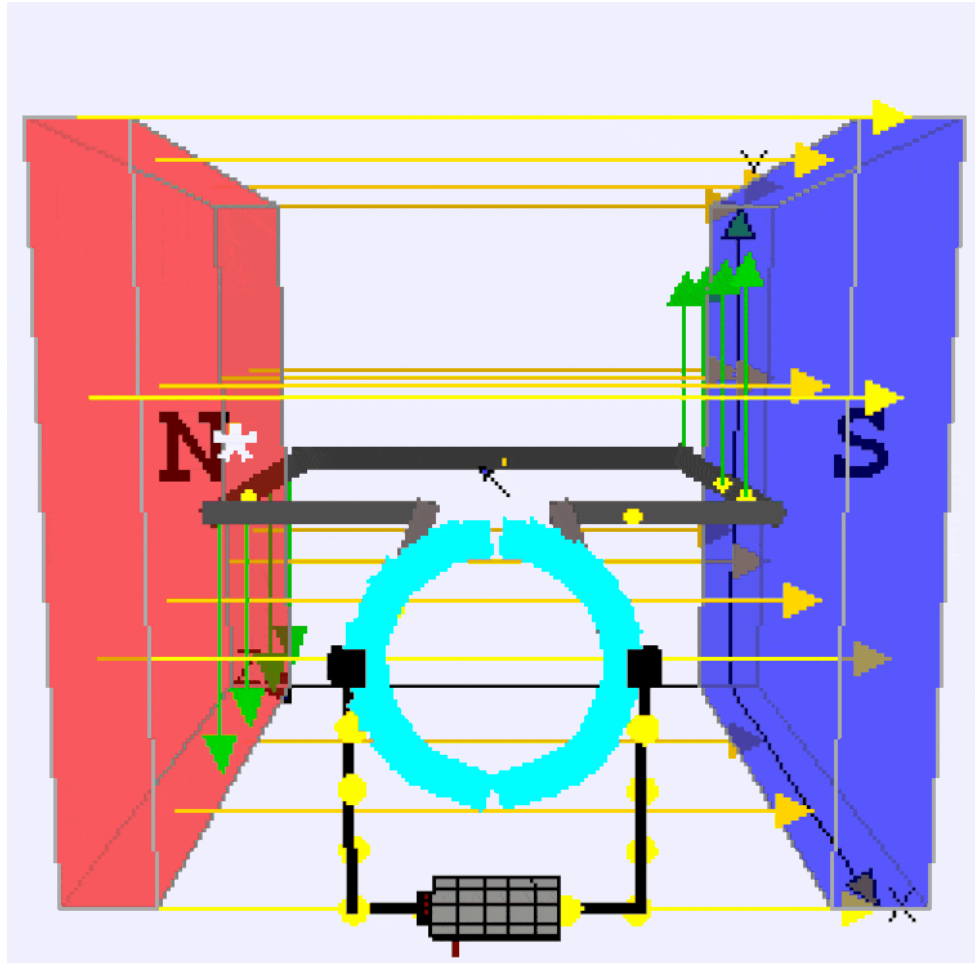
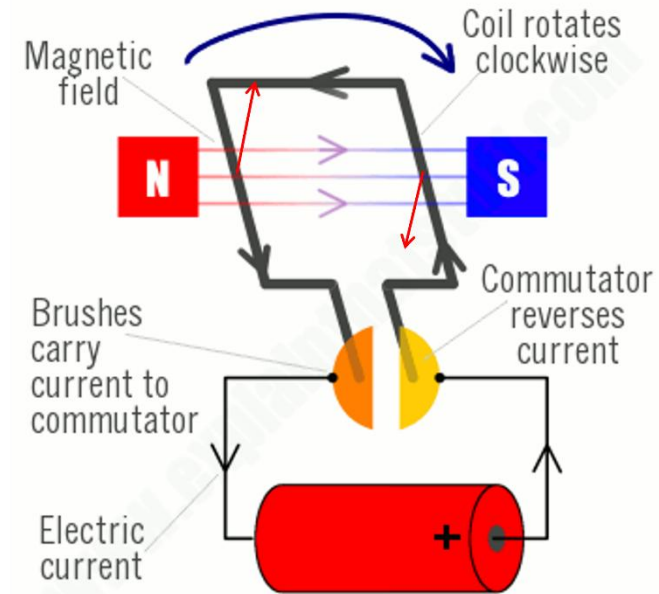

Example of Designing Analogue Sensor

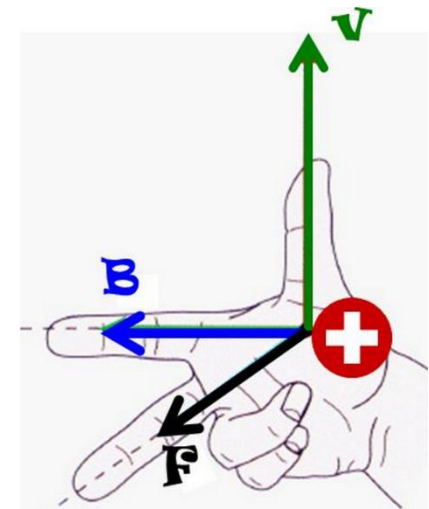
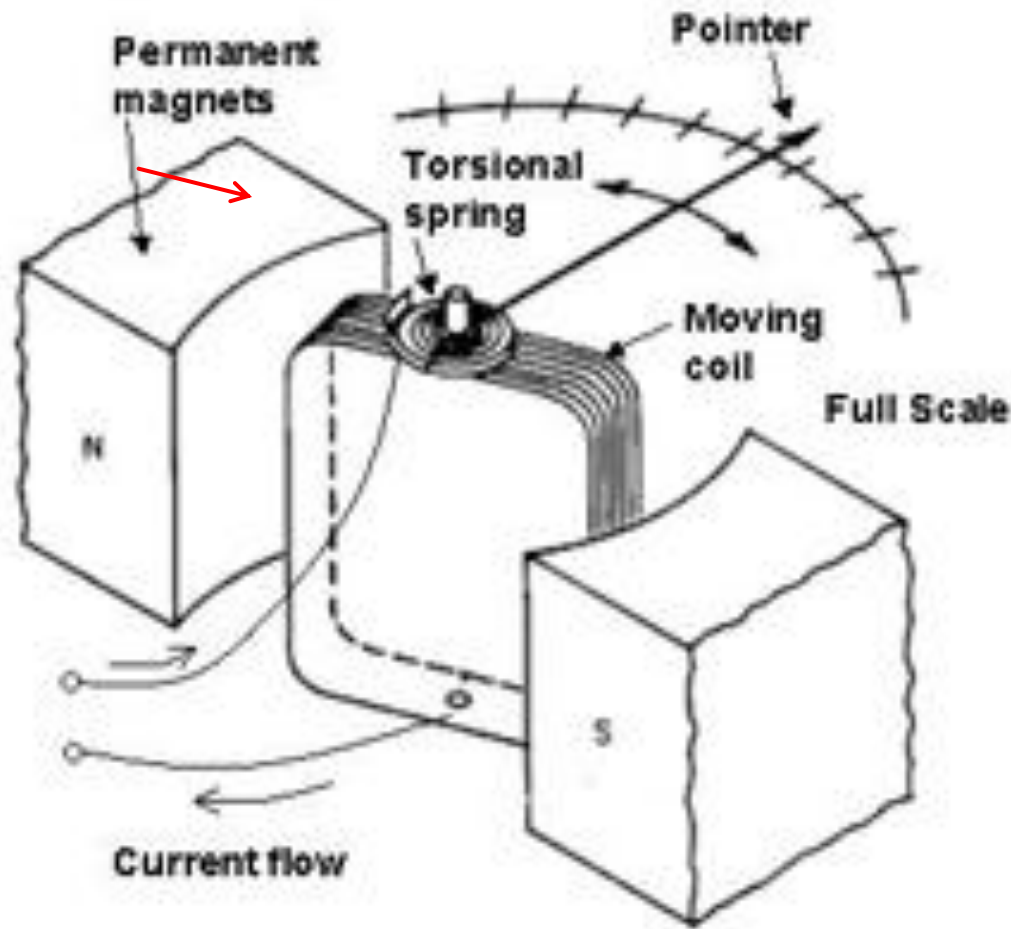

Understanding Current (8)

- ▶ A magnetic field can cause a fraction of electrons to deviate from their main path. Such an effect is called Hall Effect.

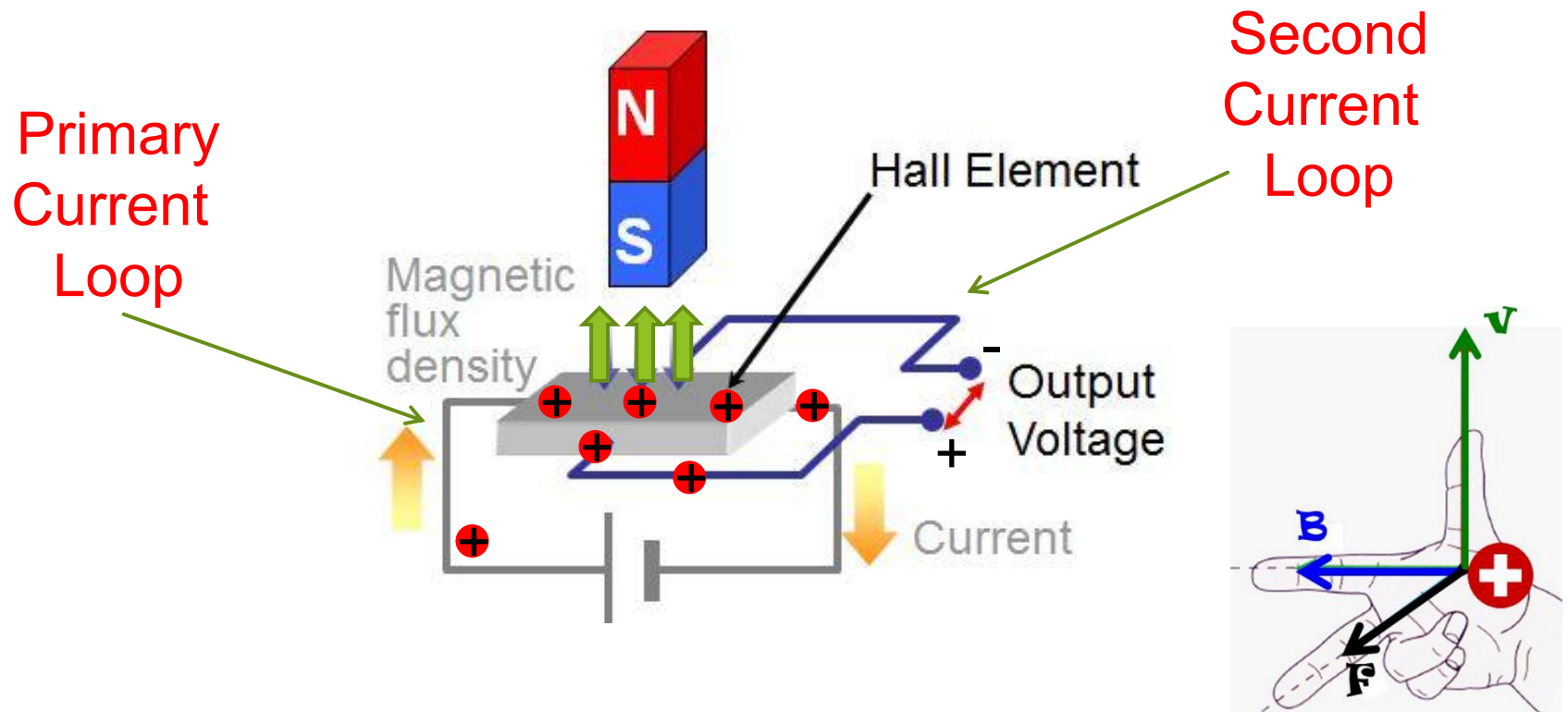

Example of Hall Effect Sensor

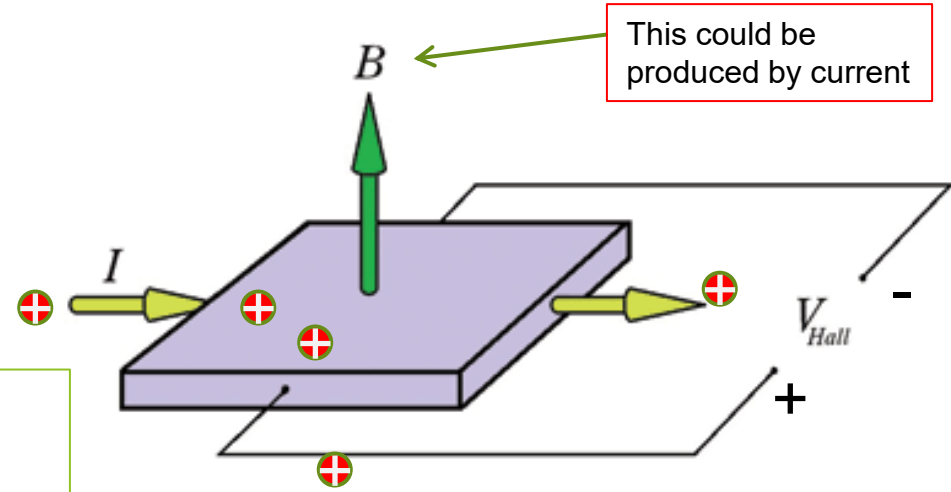

When there is no magnetic field, the electrons follow the straight path.

When there is magnetic field, the electrons follow the curved path. Hence, some electrons enter the vertical circuit and produce Hall voltage V_H .

V_H is proportional to the magnetic field density B .

B can be produced by electro-magnet.

B is proportional to the current which flows inside the electro-magnet.

$$V_{Hall} = k | I \times B |$$

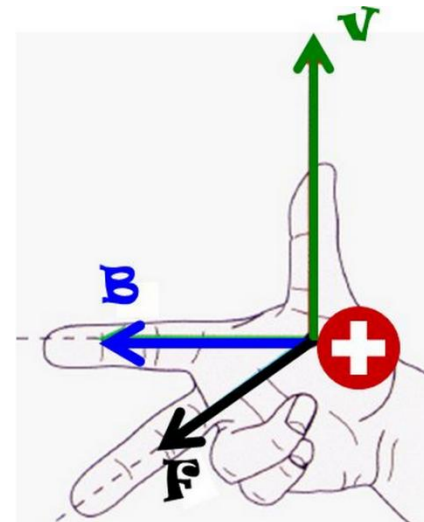

Understanding Current (9)

- ▶ Current represents electrical energy.
- ▶ Energy could be converted from one domain into another domain.



Electrical Power = Voltage x Current

Mechanical Power = Force x Velocity

Definition of Current

- ▶ The flow rate of electrons in a conductor is called **current**.

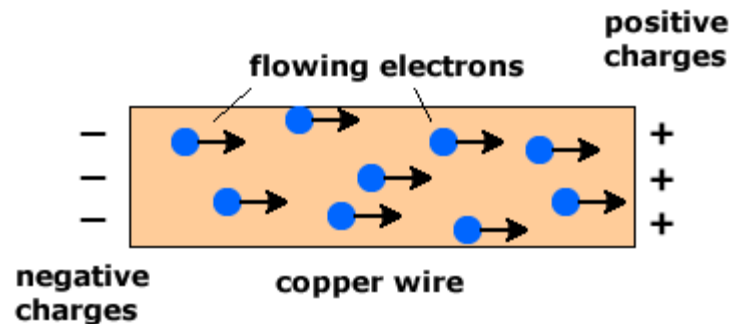

Current's Unit of Measurement

- ▶ One unit of current corresponds to the amount of electric charges passed through a conductor per unit of time. It is called one Ampere.

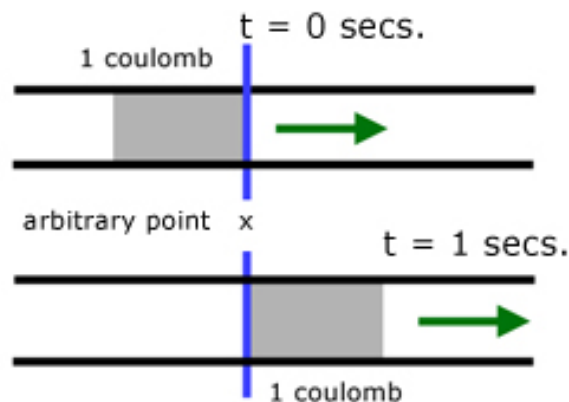

$$I = \frac{Q}{t} \text{ (Coulomb/second or Ampere)}$$

Flow Rate of Electrons

Other Related Units of Measurement

Parameter	Measuring Unit	Relationship
Voltage	volt (V or E)	$E = I \times R$
Current	amp (I)	$I = \frac{E}{R}$
Resistance	ohm (R or Ω)	$R = \frac{E}{I}$
Conductance	mho (G or \mathcal{U})	$G = \frac{1}{R} = \frac{I}{E}$
Power	watt (W)	$P = I \times E$ or $P = I^2 R$
Inductance	henry (L or H)	$V_L = -L \left(\frac{\Delta I}{\Delta t} \right)$
Capacitance	farad (C)	$C = \frac{Q}{E}$ (Q = charge)

Constant Current Source

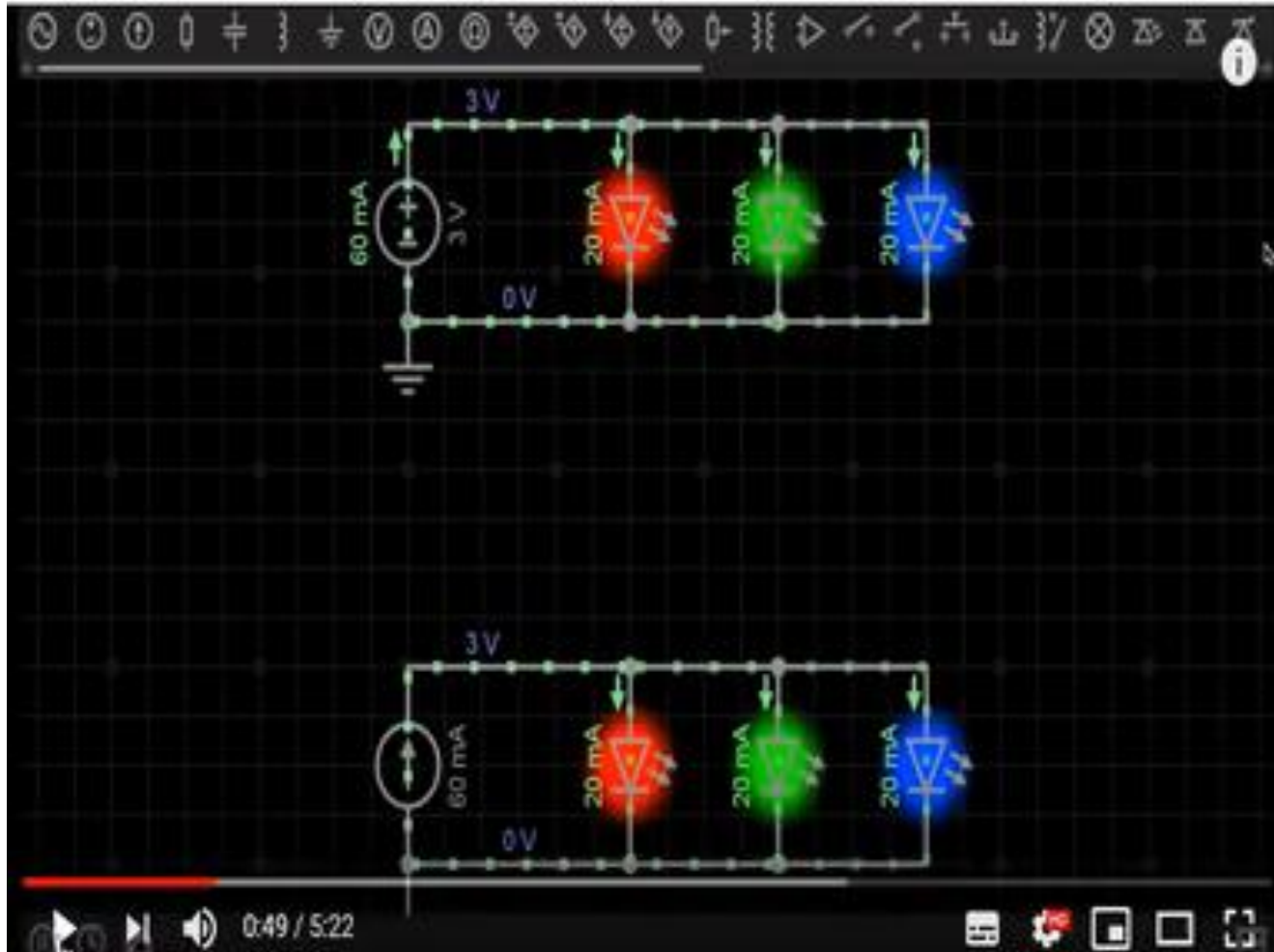

Outline

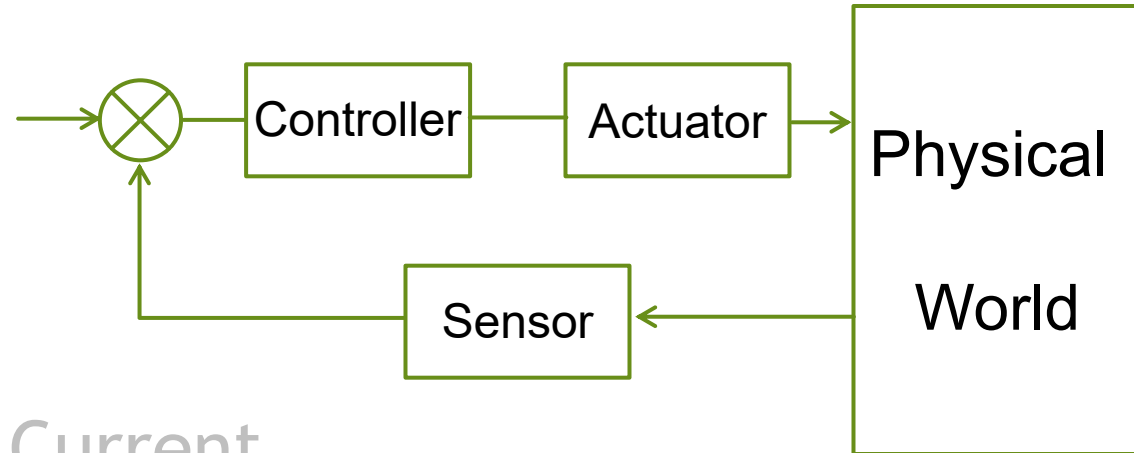

► Understanding of Current

► Computation of Current

► Measurement of Current

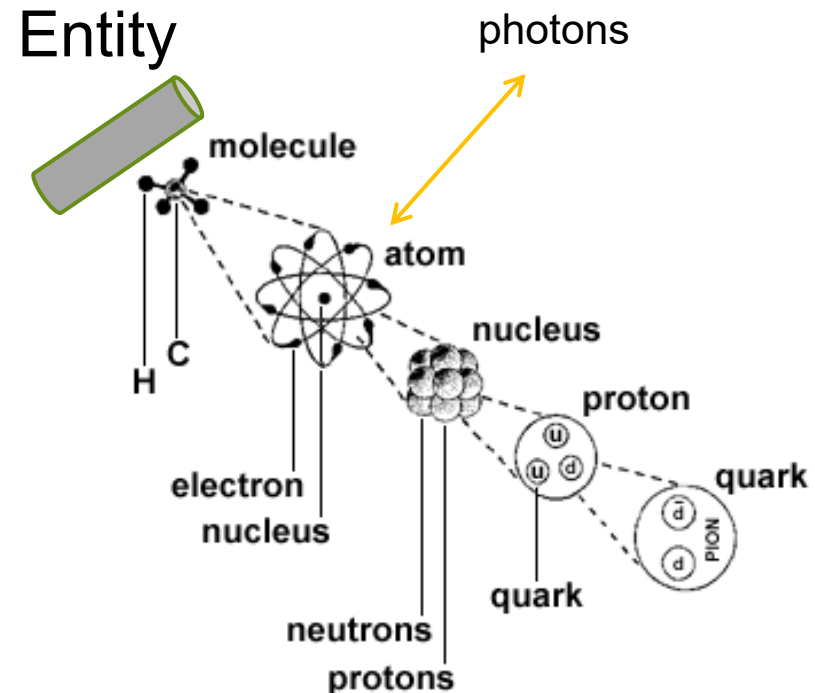

Equation of Current (1)

► System of R Circuit

$$I = \frac{V}{R}$$

Time Domain

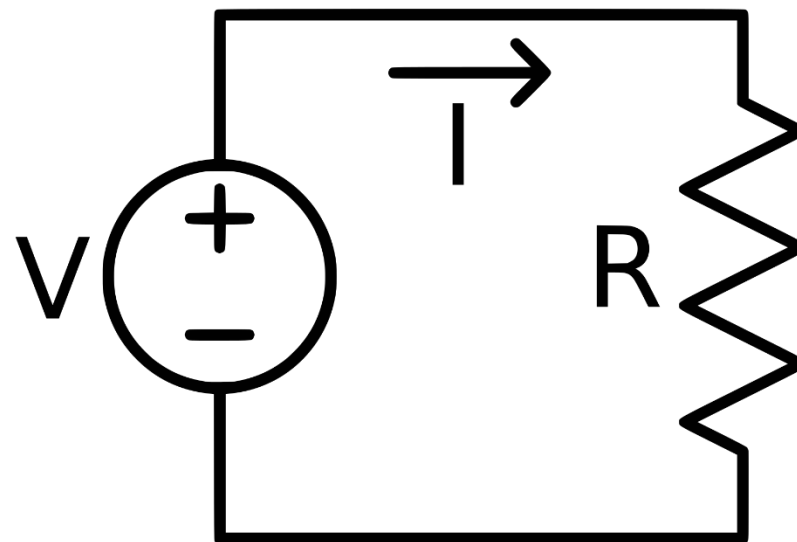

Frequency Domain

$$\frac{I(s)}{V(s)} = \frac{1}{R}$$

Relationship in Frequency Domain

$$s = \sigma + j\omega$$

Equation of Current (2)

► System of C Circuit

$$i = C \frac{dV_c}{dt}$$

Time Domain

Frequency Domain

$$\frac{I(s)}{V(s)} = C \times s$$

Relationship in Frequency Domain

$$s = \sigma + j\omega$$

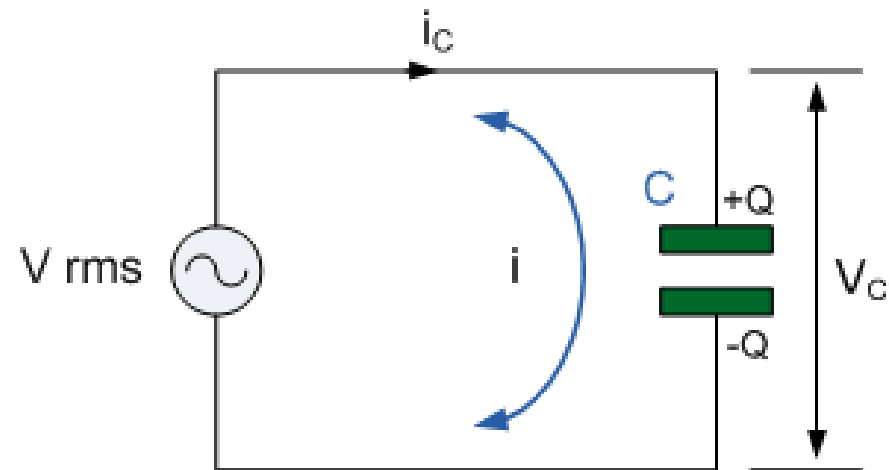

Equation of Current (3)

- System of L Circuit

$$v_L = L \frac{di}{dt}$$

$$i = \int \frac{V_L}{L} dt$$

Time Domain

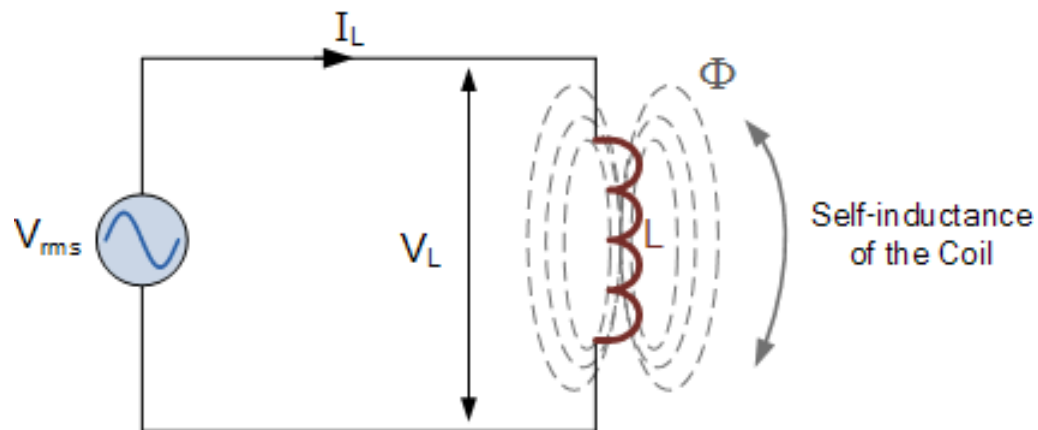

Frequency Domain

$$\frac{I(s)}{V(s)} = \frac{1}{L \times s}$$

Relationship in Frequency Domain

$$s = \sigma + j\omega$$

Equation of Current (4)

- ▶ Electro-magnetic System

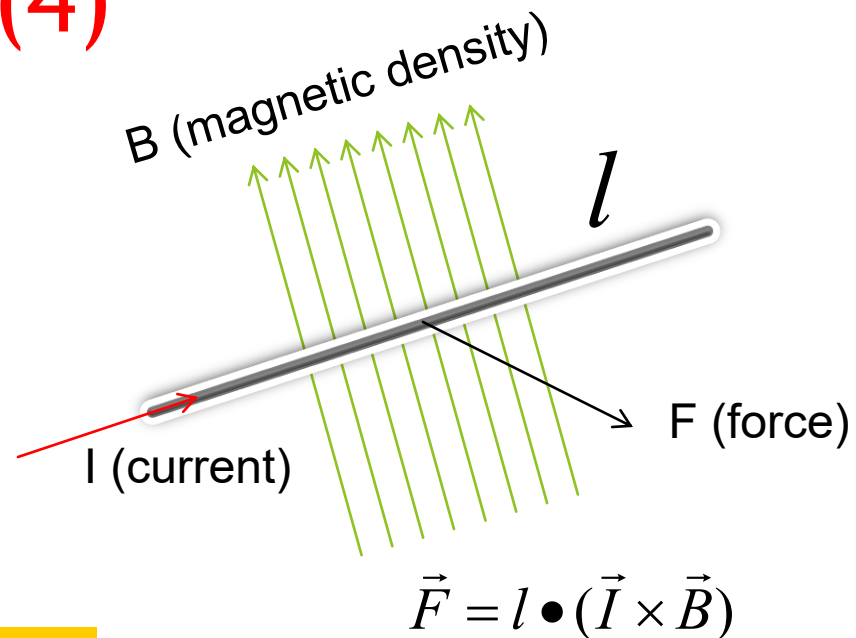

$$F = l \bullet B \bullet I$$

Length of conductor

Density of
Magnetic field

Current

Equation of Current (5)

► Electro-magnetic System

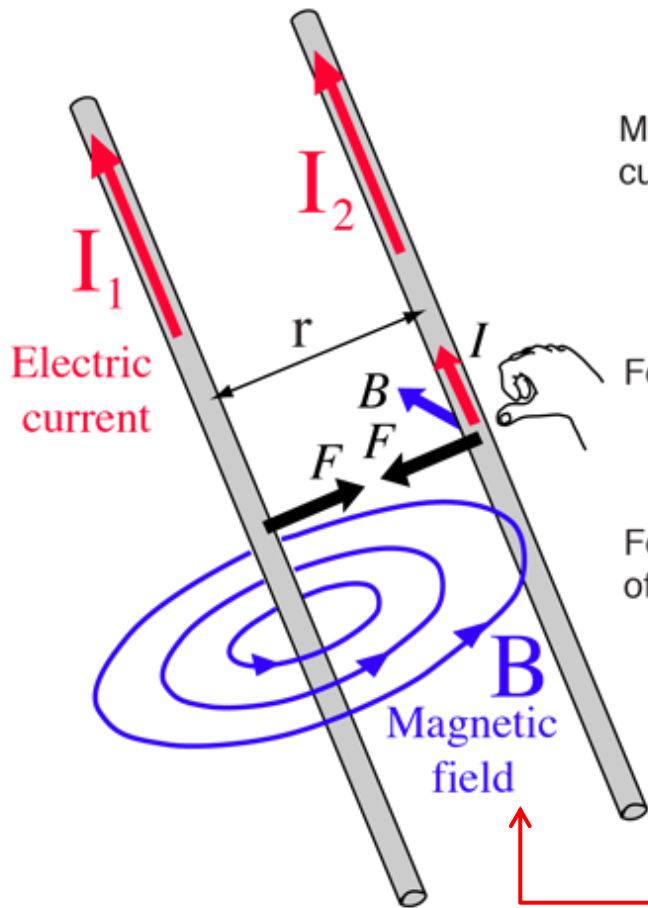

Magnetic field at wire 2 from current in wire 1:

$$B = \frac{\mu_0 I_1}{2\pi r}$$

Force on a length ΔL of wire 2:

$$F = I_2 \Delta L B$$

Force per unit length in terms of the currents:

$$\frac{F}{\Delta L} = \frac{\mu_0 I_1 I_2}{2\pi r}$$

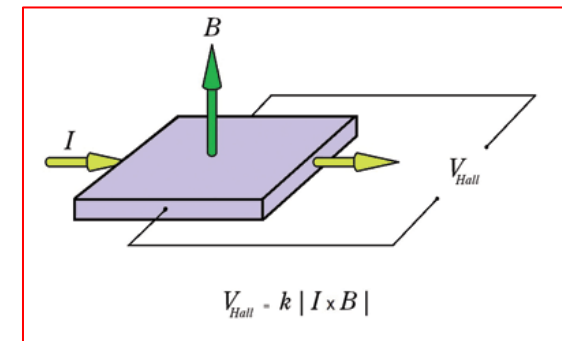
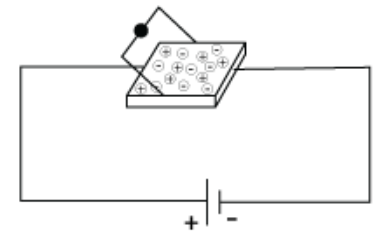

Design Idea of Contactless Sensor

Outline

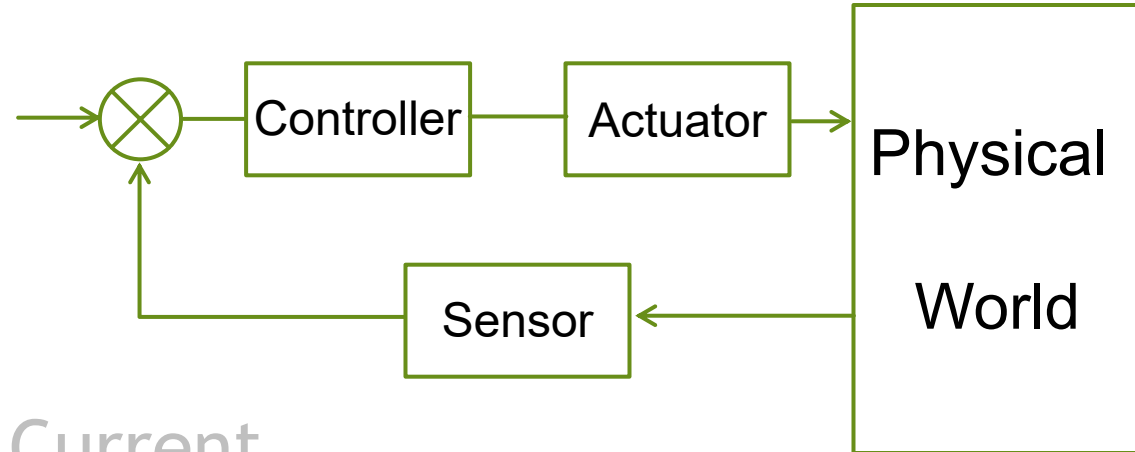

► Understanding of Current

► Computation of Current

► Measurement of Current

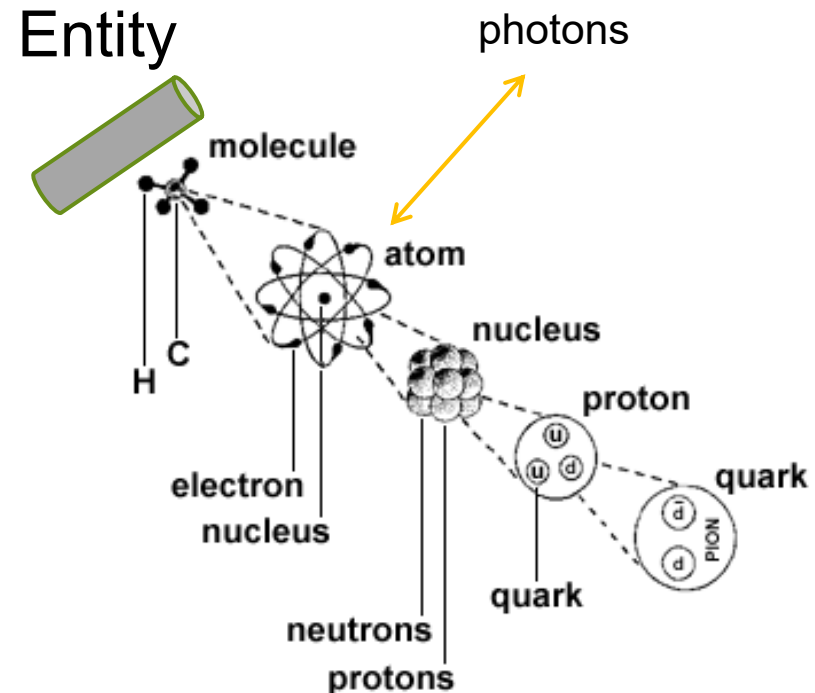

Requirement of Doing Current Measurement

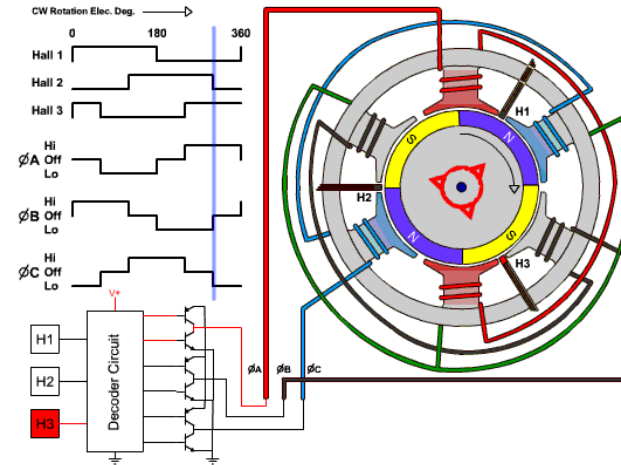
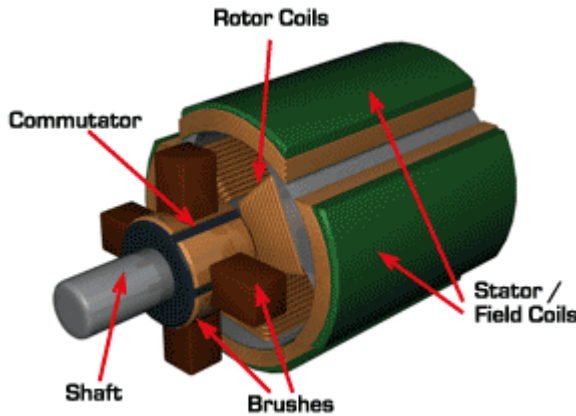

$$\tau = k \times i$$

$$v \times i = \tau \times \omega$$

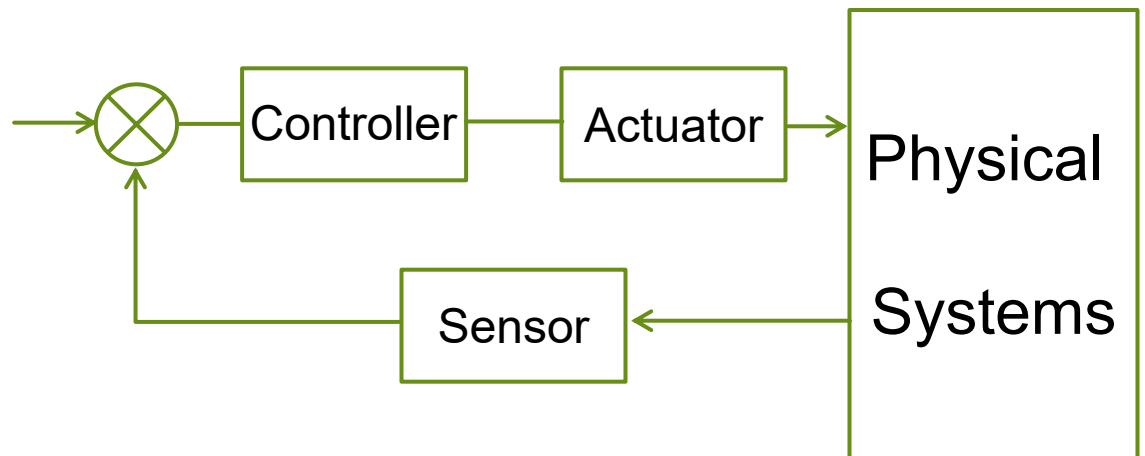
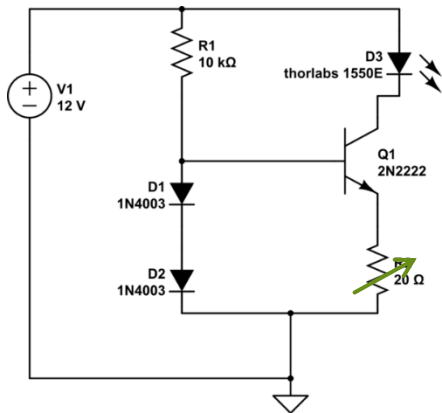

Example of Current/Torque Control

$$\tau = k \times i \quad v \times i = \tau \times v$$



Principles of Measuring Current

- ▶ Current produces electro-magnet field which can interact with another electro-magnetic field.
- ▶ Current produces electro-magnet field which deviates a primary circuit's electrons into a secondary circuit.
- ▶ Current could be converted into voltage with the use of resistor/capacitor/inductor.

Magnetic Force Methods

- ▶ A rotor is subject to two sources of torques.
- ▶ One is from the torsional springs.
- ▶ The other is from the electro-magnet of a current under measurement.
- ▶ When the two torques are equal in magnitude and opposite in direction, the reading from a scale indicates the value of the current under measurement.

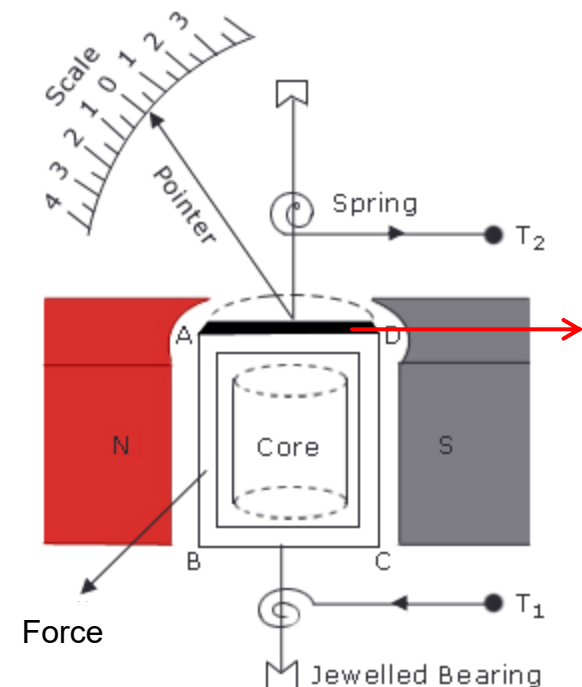

Equation Relating Current to Torque

$$\vec{F} = I \cdot (\vec{l} \times \vec{B})$$

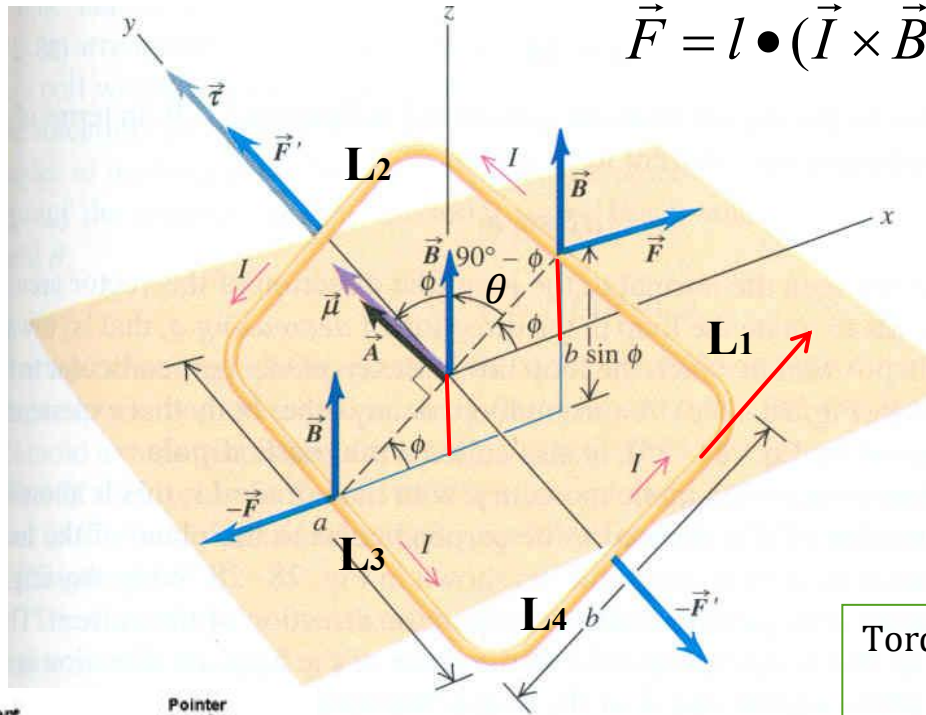

Electromagnetic force on L1:

$$F_1 = L_1 \cdot I \cdot B$$

Electromagnetic force on L3:

$$F_3 = -L_3 \cdot I \cdot B$$

Torque produced by F_1 about Y axis:

$$\tau_1 = \left(\frac{b}{2} \sin(\phi)\right) \cdot F_1 = \left(\frac{b}{2} \sin(\phi)\right) \cdot a \cdot I \cdot B$$

Torque produced by F_3 about Y axis::

$$\tau_3 = \left(-\frac{b}{2} \sin(\phi)\right) \cdot F_3 = \left(\frac{b}{2} \sin(\phi)\right) \cdot a \cdot I \cdot B$$

$$\phi = \frac{\pi}{2} - \theta$$

$$\theta = \frac{\pi}{2} - \phi$$

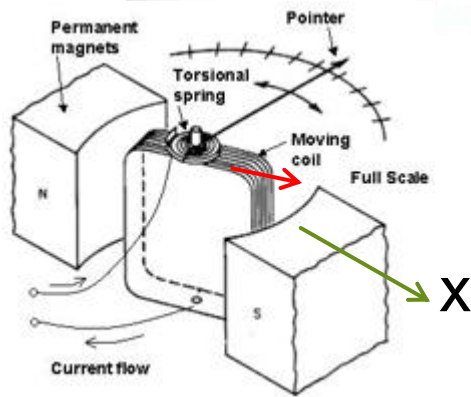

Equation Relating Current to Angle

Torque from current:

$$\tau_i = k \cdot I \cdot \sin\left(\frac{\pi}{2} - \theta\right)$$

Torque from spring:

$$\tau_s = c \cdot \theta$$

Equality of both torques:

$$k \cdot I \cdot \sin\left(\frac{\pi}{2} - \theta\right) = c \cdot \theta$$

Equation of current:

$$I = \frac{c}{k} \cdot \frac{\theta}{\sin\left(\frac{\pi}{2} - \theta\right)}$$

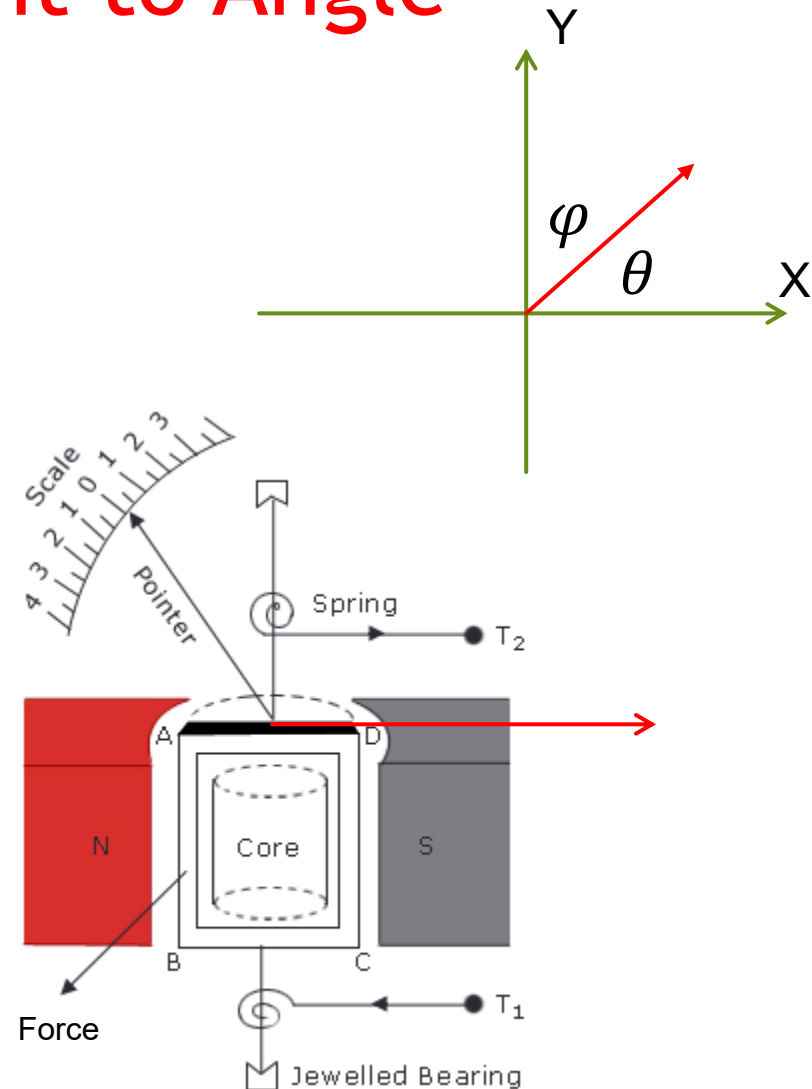

Conceptual Design: Ammeter

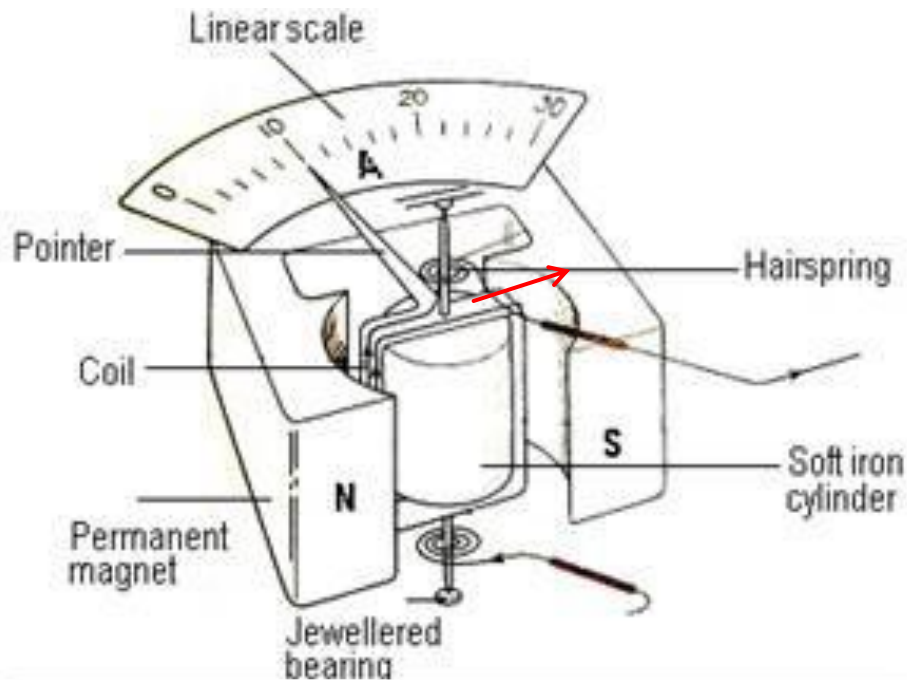

Hall Effect Methods

- ▶ A current under measurement passes through coils or a conductor in order to produce electro-magnetic field which is applied to a Hall sensor.
- ▶ The primary loop of the Hall sensor is internally built-up.
- ▶ The secondary loop of the Hall sensor will output a voltage, which can be measured.
- ▶ By calibration, the output could be related to the current under measurement.

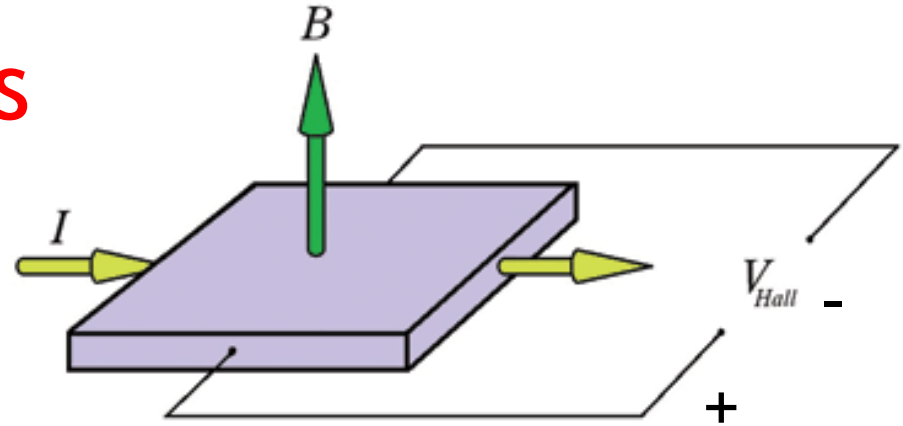

$$V_{Hall} = k |I \times B|$$

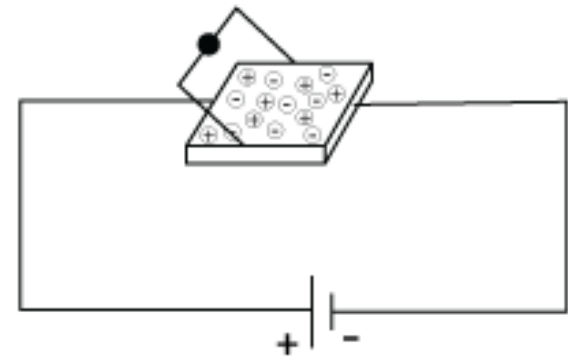

Conceptual Design: Hardware

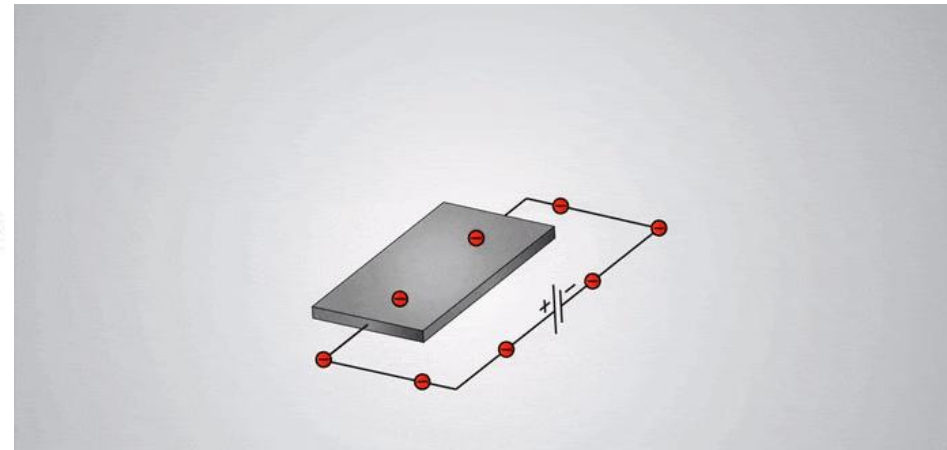
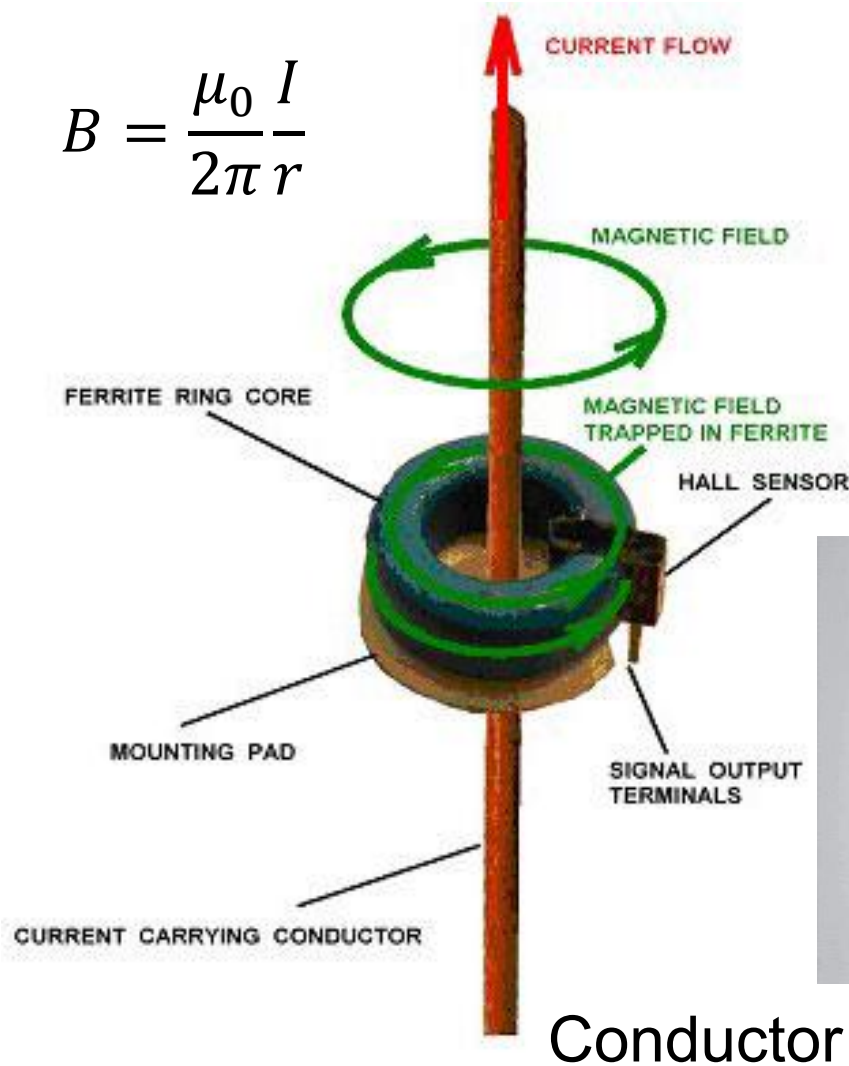

Conceptual Design: Signal Circuit

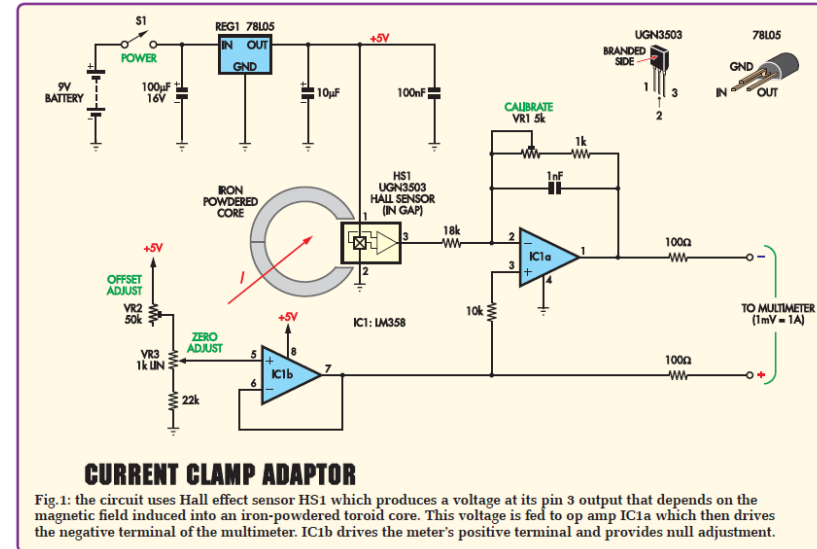
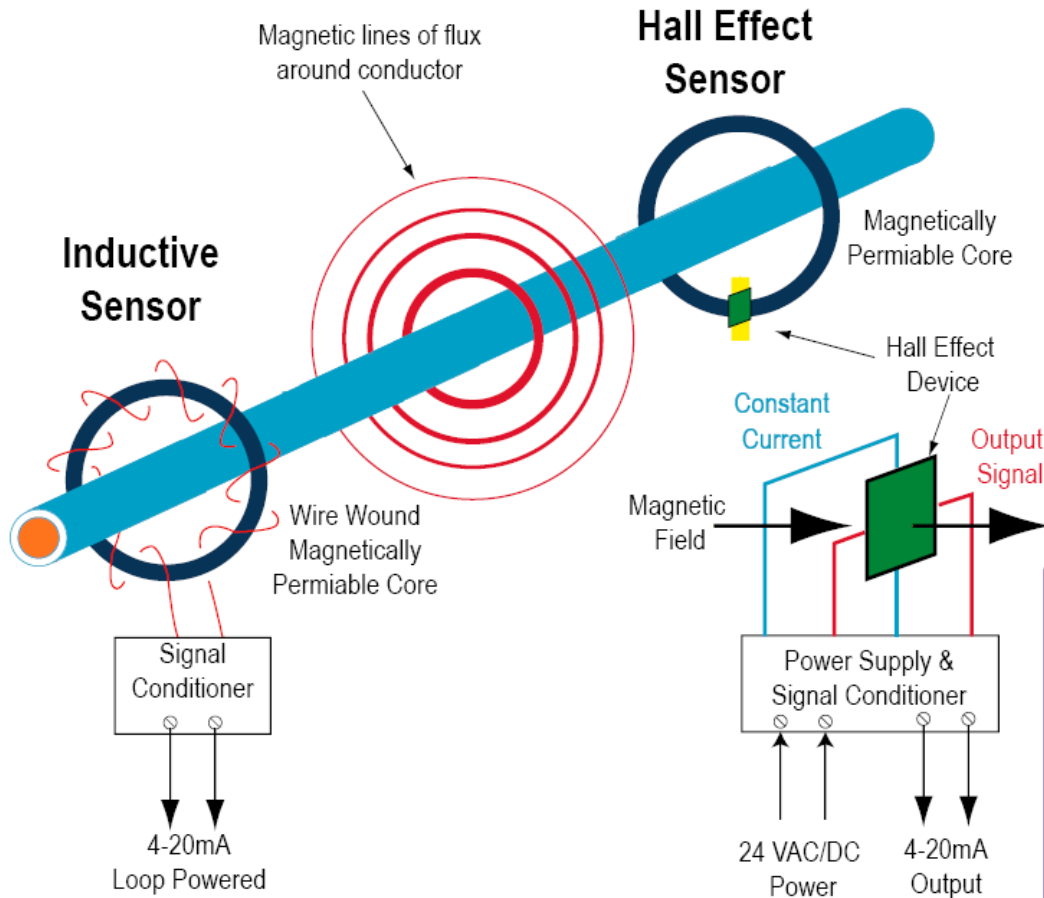

Voltage Methods

- ▶ If the current is very high, let the current under measurement to pass through a special resistor called **Shunt**.
- ▶ The voltage drop across the resistor or shunt can be measured.
- ▶ The values of current could be computer-readable and human-readable.
- ▶ In this way, voltmeter becomes ammeter.

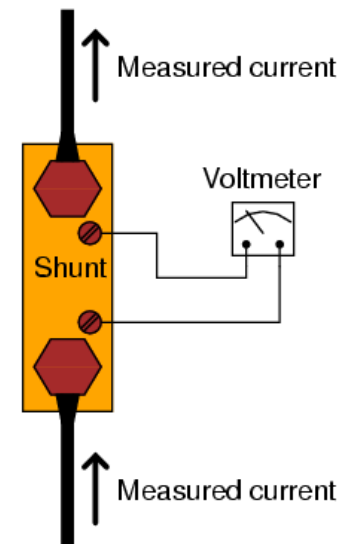
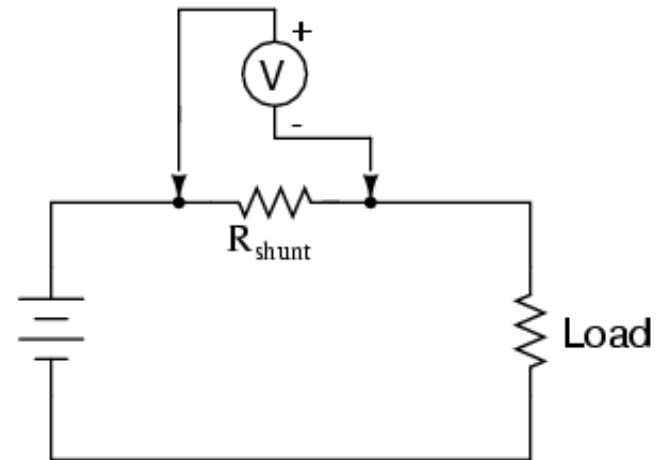

What is a shunt (i.e. special resistor)?

An ammeter's shunt allows the measurement of current values too large to be directly measured by a particular ammeter. In this case the **shunt**, a resistor of accurately known resistance, is placed in series with the load so that all of the current to be measured will flow through it. In order not to disrupt the circuit, the resistance of the shunt is normally very small. The voltage drop across the shunt is proportional to the current flowing through it and since its resistance is known, a voltmeter connected across the shunt can be scaled to directly display the current value.



Example of Ammeter Which Could Measure Currents in Multiple Ranges ...

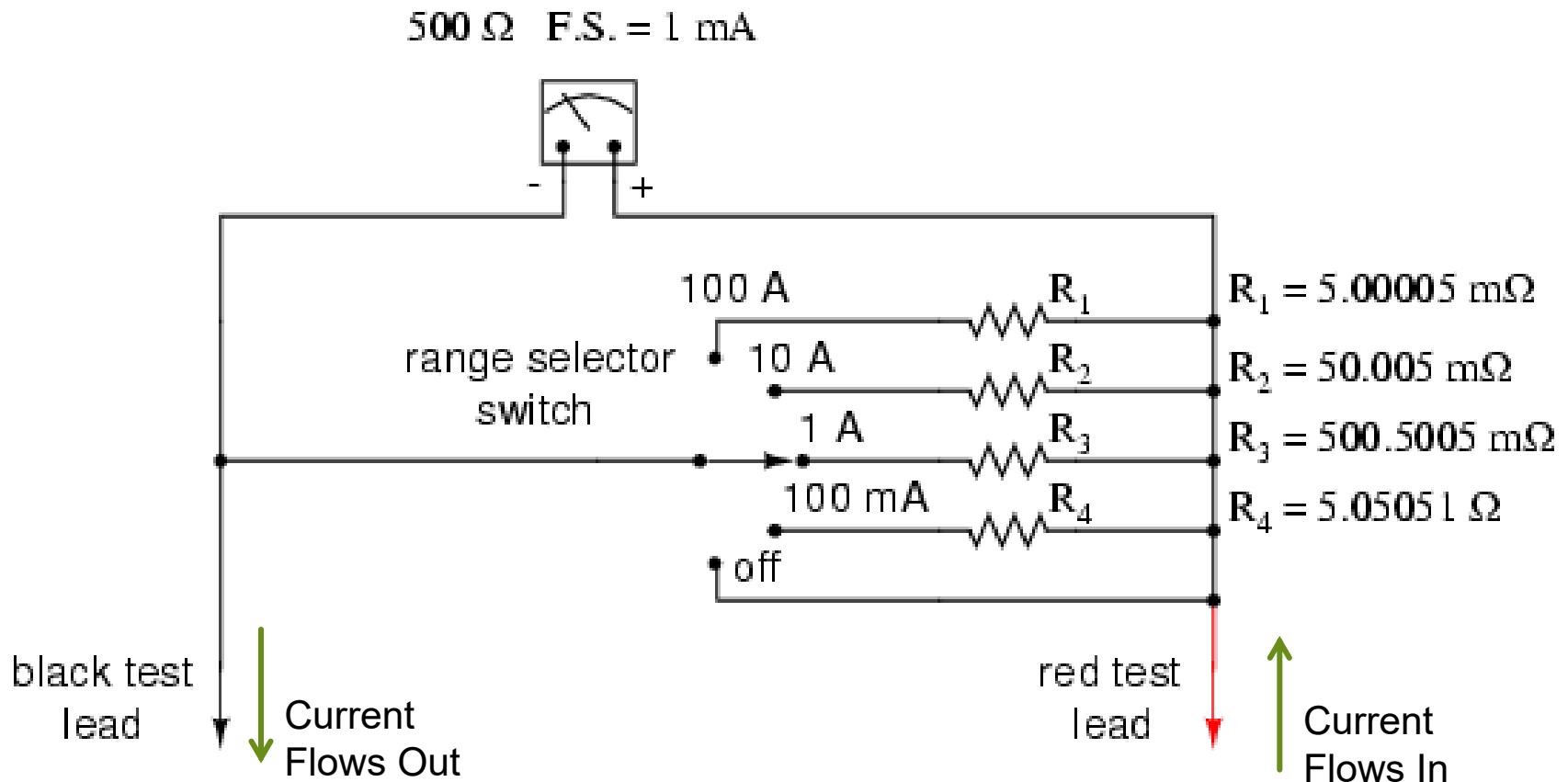

How to design digital measurement and sensing systems for current?

- ▶ Current is converted to voltage which is measured by digital voltmeter.

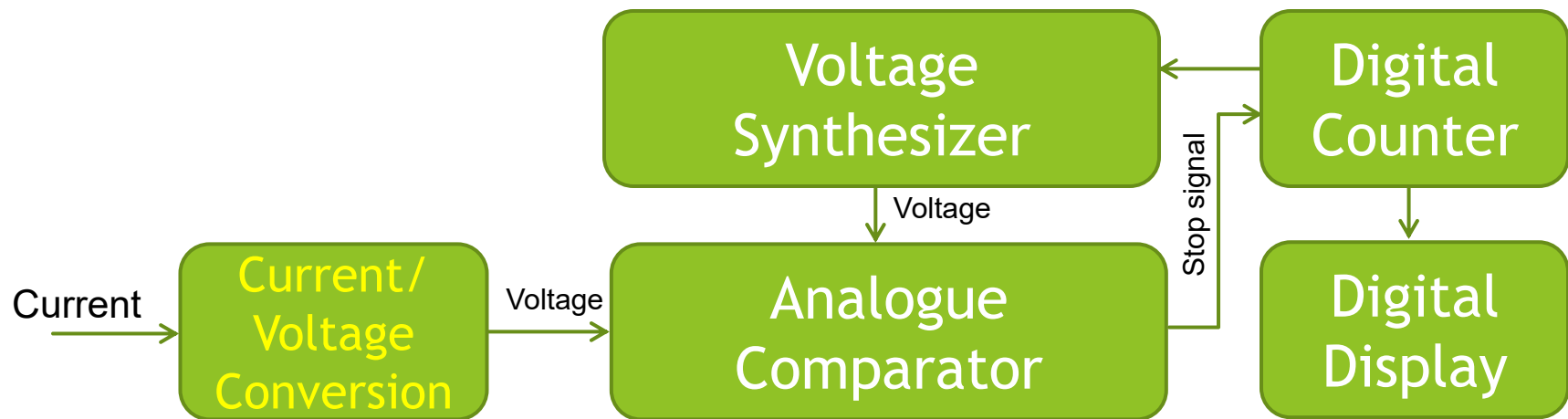

All microcontrollers are programmable digital sensors of voltage!

How To Convert High Current to Voltage?

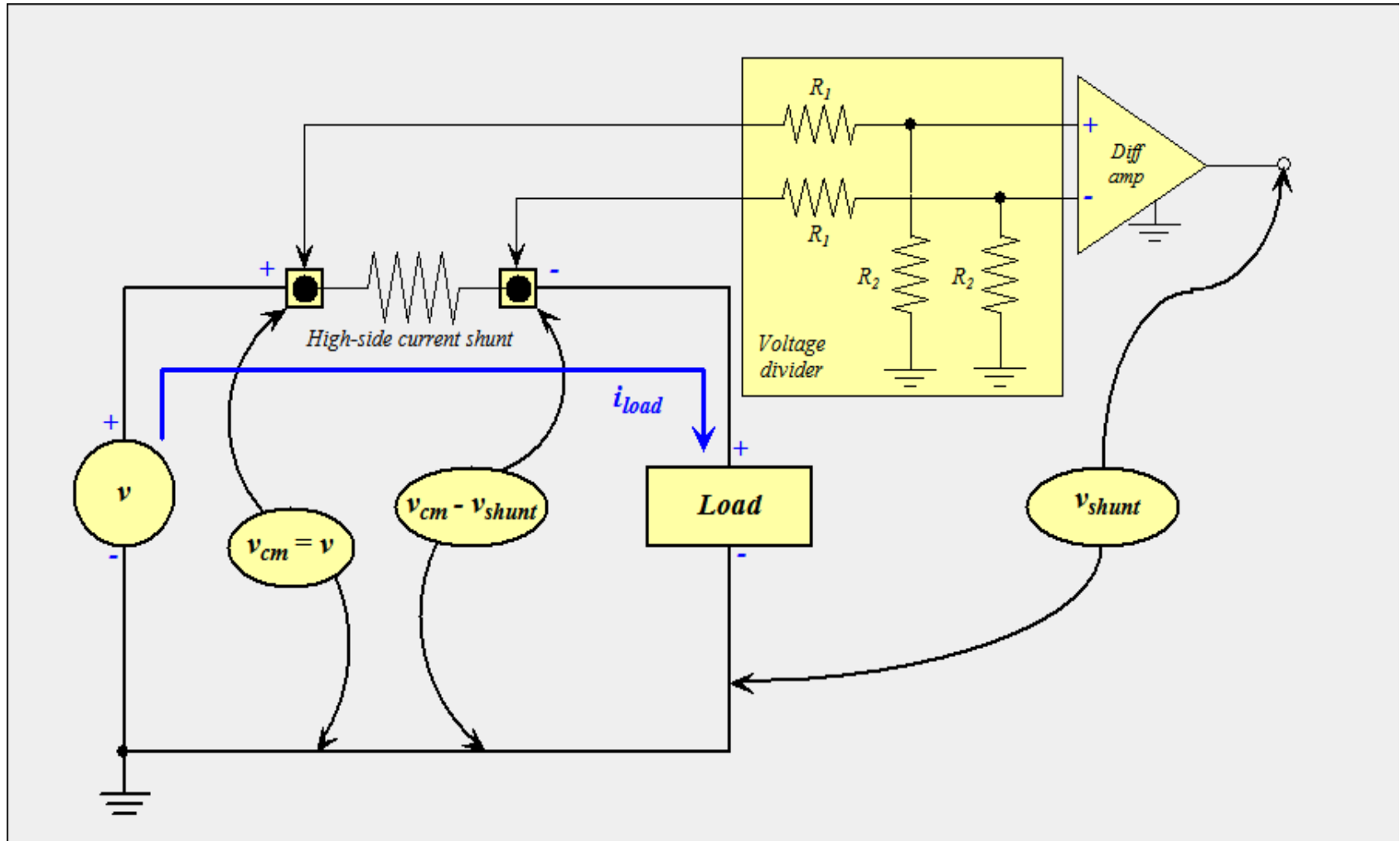

How To Convert Normal Current to Voltage?

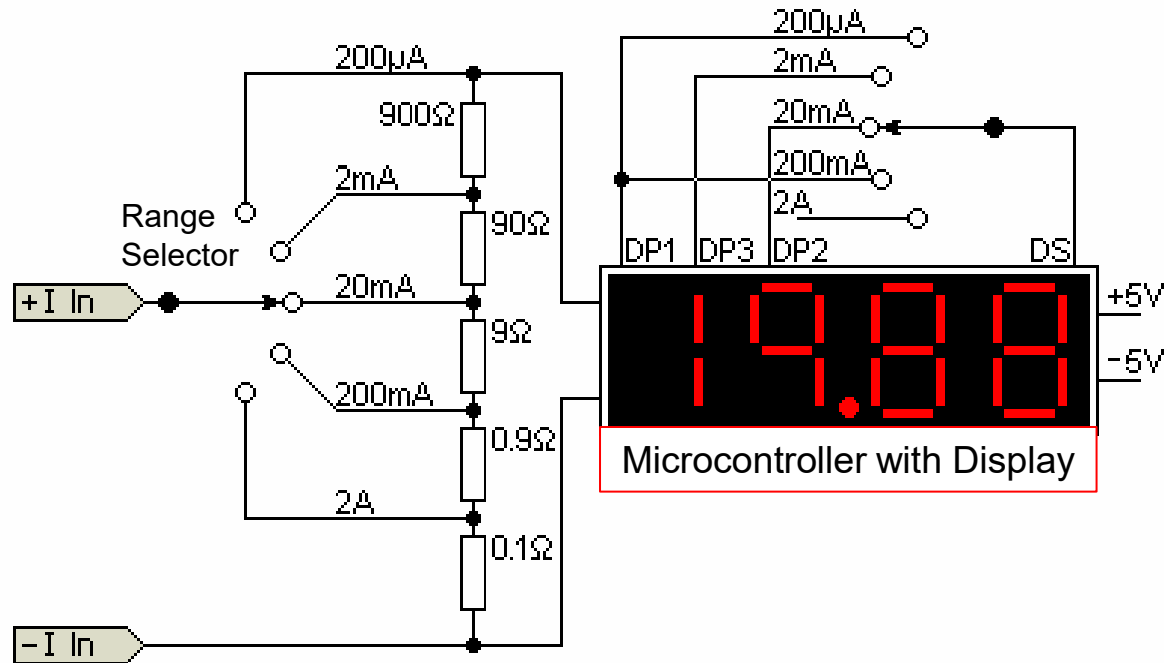

Remember to Do Calibration

- ▶ Curve fitting for calibration:
 - ▶ Y_i is produced by X_i
 - ▶ Z_i is computed from Y_i
 - ▶ Z_i must be equal to X_i

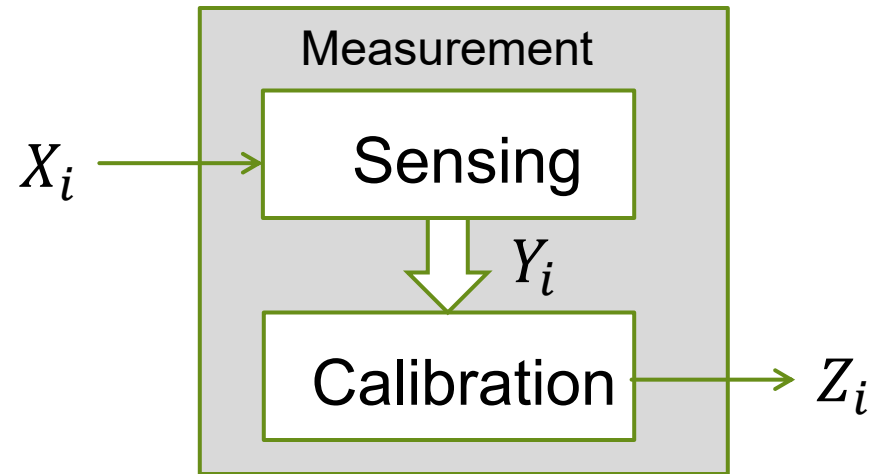

Calibrated Values Z_i

Measured Values Y_i

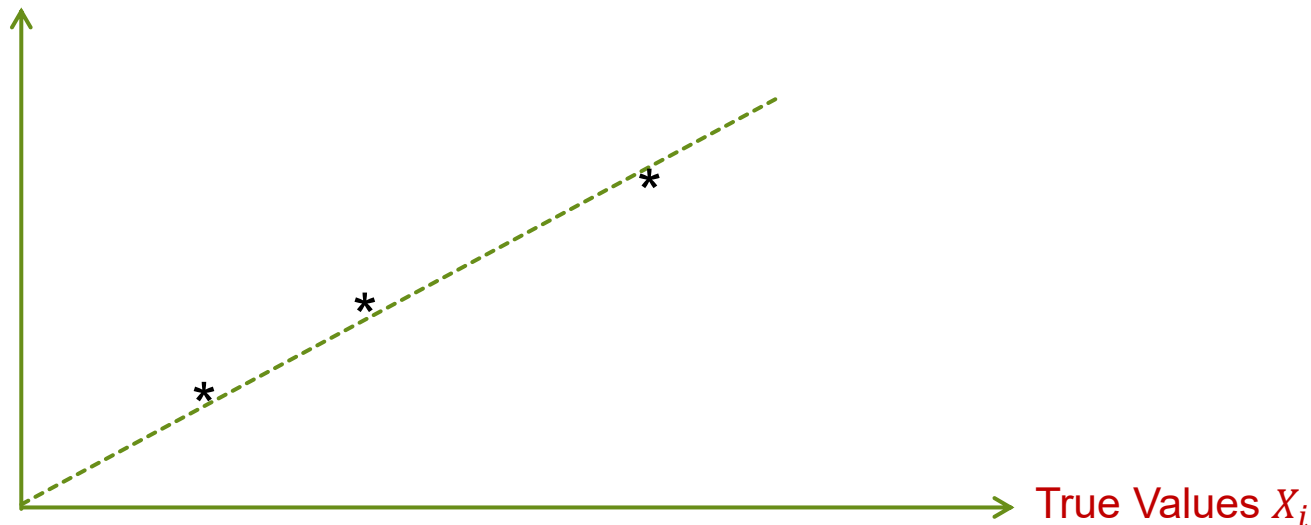

What is the standard of 1 Ampere when doing the calibration of Ammeter?

▶ Answer:

- ▶ One ampere is the constant current that will produce an attractive force of 2×10^{-7} Newtons **per meter** of length between **two straight and parallel conductors** of infinite length and negligible circular cross section placed **one metre apart in a vacuum**.

Remember to Do Error Analysis

- ▶ Systematic error = **mean value** - **true value**
- ▶ Repeatability error = value with maximum error - **mean value**
- ▶ Accuracy = value with minimum error - **mean value**
- ▶ Hysteresis error = |measured value in increasing - measured value in decreasing|

For each true value, we can do error analysis

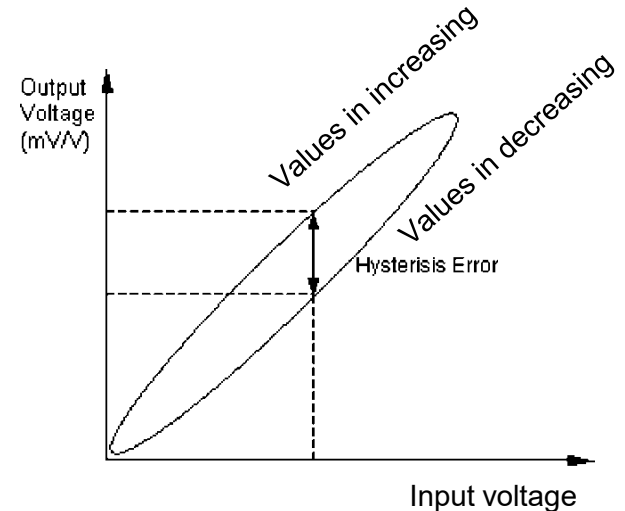
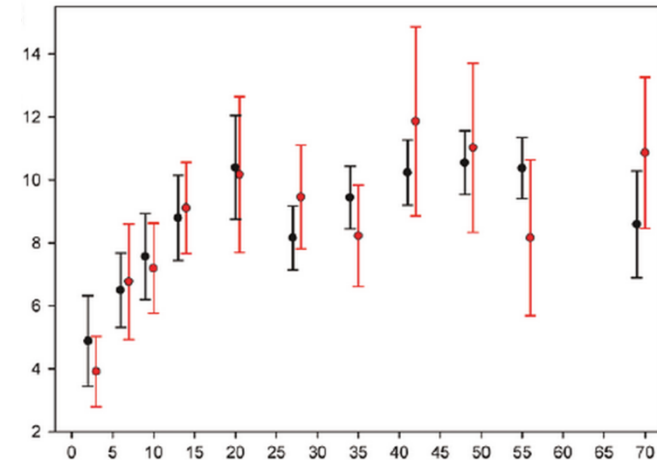

Example

- ▶ In a calibration test, 10 measurements using an ammeter have been made of a circuit that is known to have a true current of 2.0 amperes. The readings are: 1.98, 2.05, 2.10, 2.06, 1.99, 1.96, 2.02, 2.09, 2.03, and 1.99 amperes. What is the systematic error? And, what is the repeatability error?
- ▶ Answer:
 - ▶ Mean value of measurements is: $I_{\text{aver}} = 2.027$ amperes
 - ▶ Systematic error = $I_{\text{aver}} - I_{\text{true}} = 2.027 - 2.0 = 0.027$ amperes
 - ▶ Repeatability error = $I_{\text{max}} - I_{\text{aver}} = 2.10 - 2.027 = 0.073$ amperes

Summary

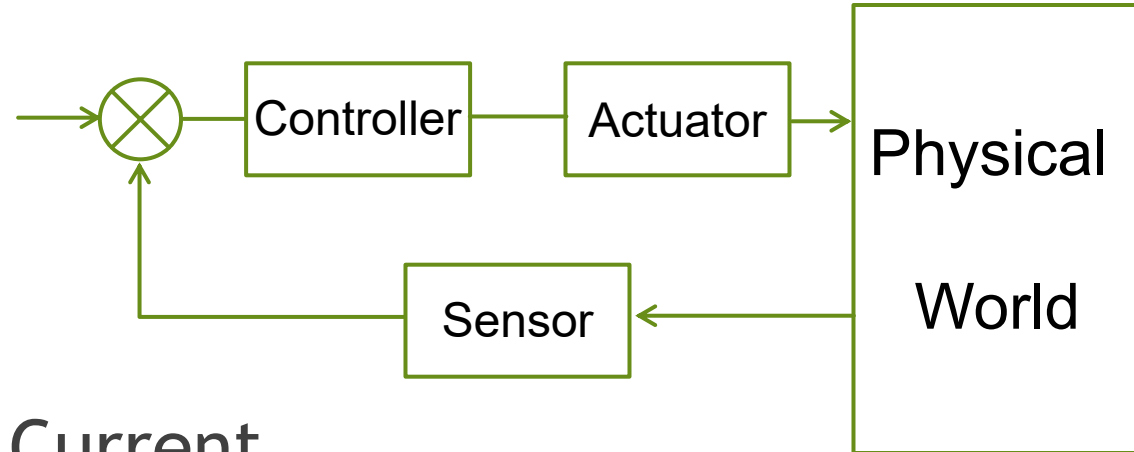

► Understanding of Current

► Computation of Current

► Measurement of Current

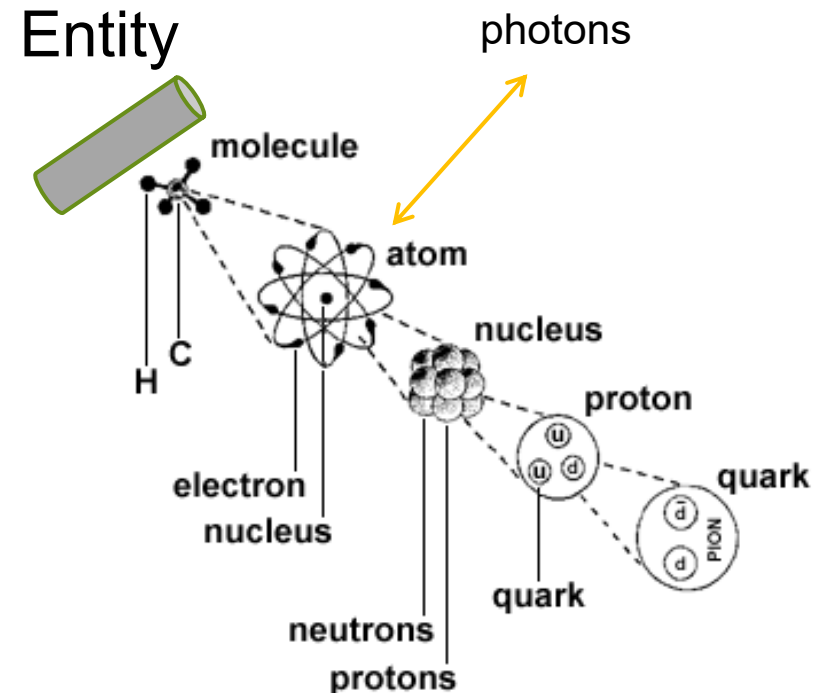

Outline of Module 2

- ▶ Lecture 1:
 - ▶ Measurement of Voltage
- ▶ Lecture 2:
 - ▶ Measurement of Current
- ▶ Lecture 3:
 - ▶ Measurement of Resistance
- ▶ Lecture 4:
 - ▶ Measurement of Capacitance
- ▶ Lecture 5:
 - ▶ Measurement of Inductance

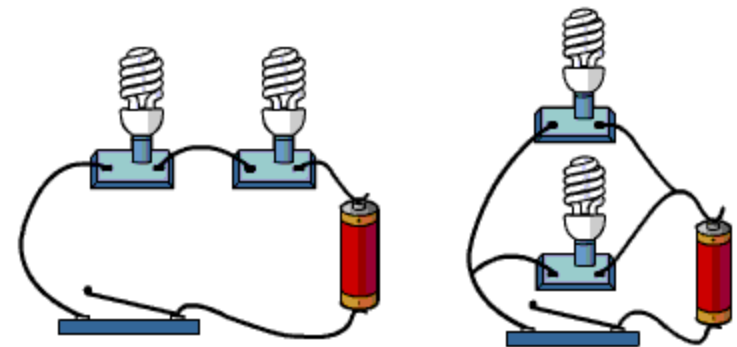

Series Circuit

Parallel Circuit

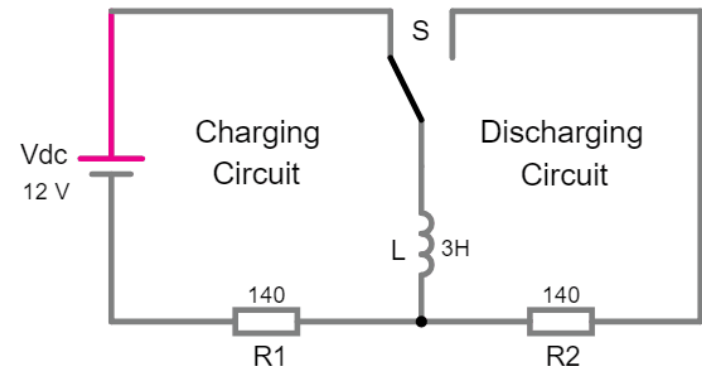
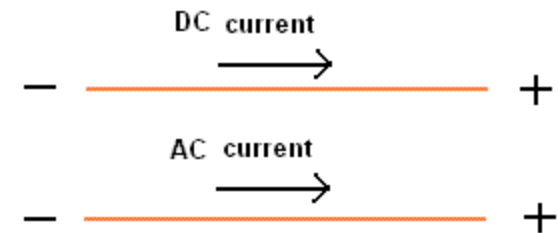



**NANYANG
TECHNOLOGICAL
UNIVERSITY**

School of Mechanical & Aerospace Engineering

Design, Machine, Control, Intelligence

Module 2 Lecture 3

MA4822

Measurement of Resistance

Xie Ming, PhD (France)

mmxie@ntu.edu.sg

<http://personal.ntu.edu.sg/mmxie>

Outline

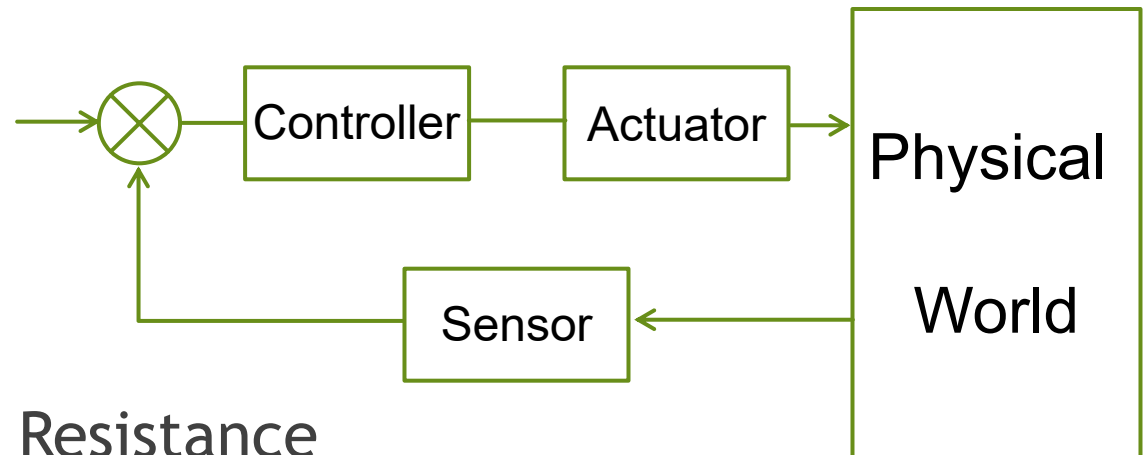

- ▶ Understanding of Resistance
- ▶ Computation of Resistance
- ▶ Measurement of Resistance

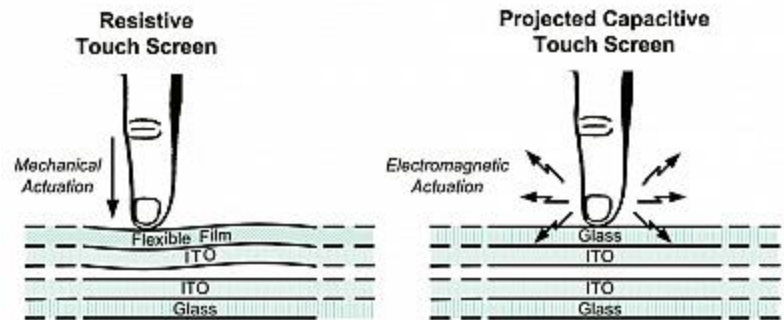

Resistor is a sensing element

Both **resistive** and **capacitive** technologies have a strong electrical component, both use ITO (Indium-Tin-Oxide, a clear conductor), and both will be around for a long time to come. A **resistive** touchscreen consists of a **flexible** top layer, then a layer of ITO (Indium-Tin-Oxide), an air gap and then another layer of ITO.

Outline

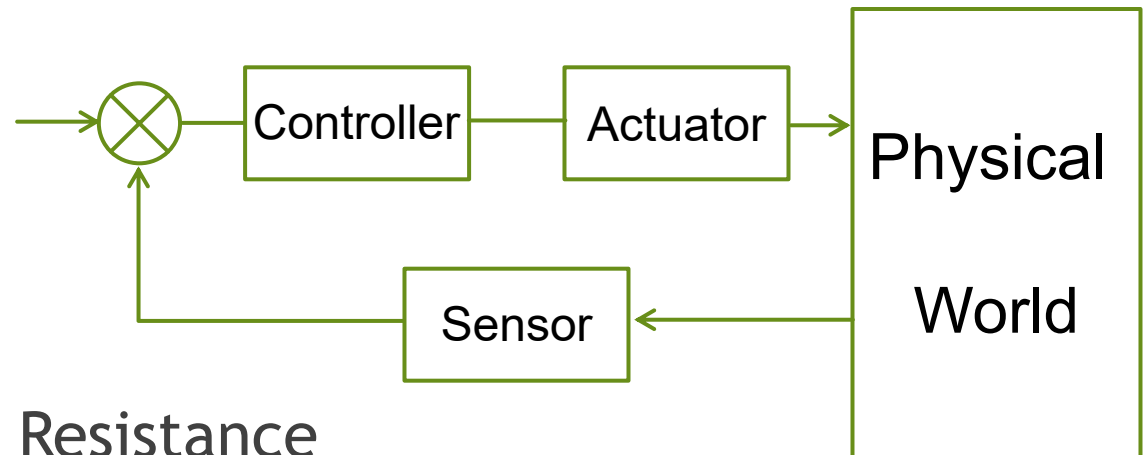

- ▶ Understanding of Resistance
- ▶ Computation of Resistance
- ▶ Measurement of Resistance

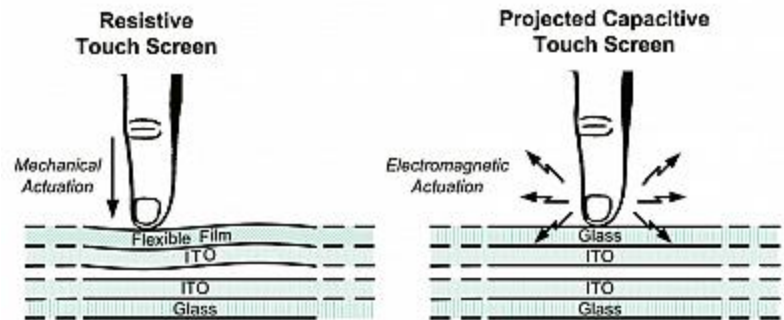

Resistor is a sensing element

Both **resistive** and **capacitive** technologies have a strong electrical component, both use ITO (Indium-Tin-Oxide, a clear conductor), and both will be around for a long time to come. A **resistive** touchscreen consists of a **flexible** top layer, then a layer of ITO (Indium-Tin-Oxide), an air gap and then another layer of ITO.

Definition of Conductor/Insulator

- ▶ Conductor refers to any material **which allows** electrons to pass through it without difficulties.
- ▶ Insulator refers to any material **which does not** allow electrons to pass through it.

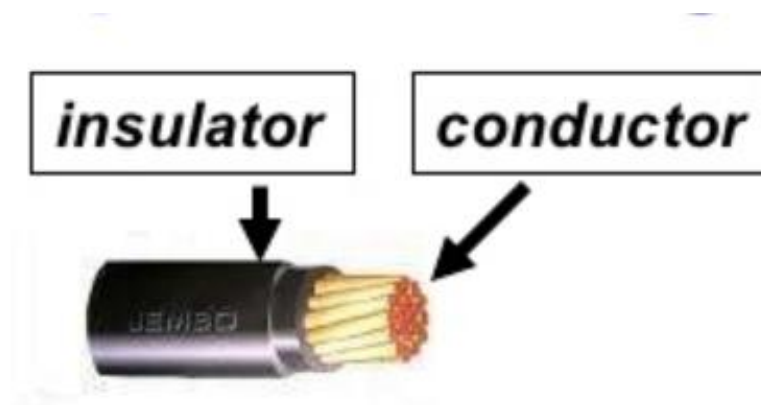

Definition of Resistor

- ▶ Resistor refers to any material which allows electrons to pass through it with **certain levels of difficulties**.

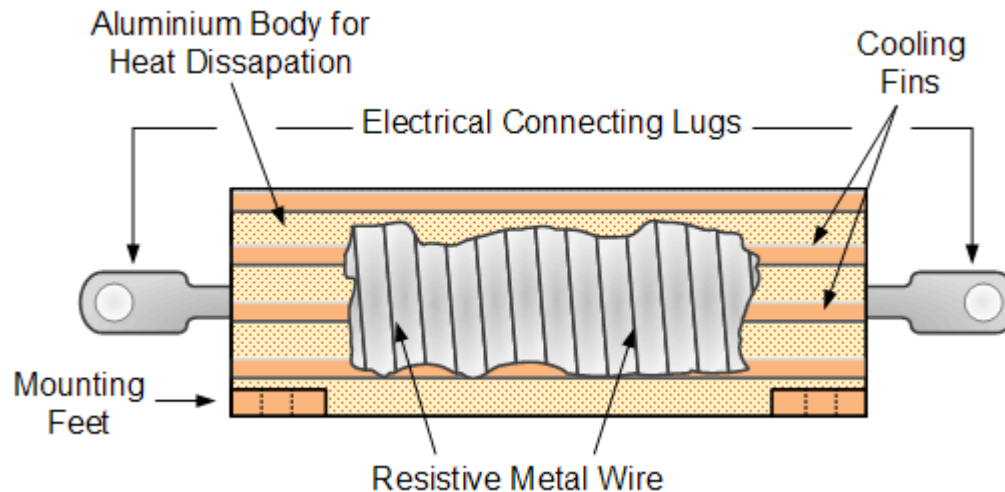

Example of Resistor Design

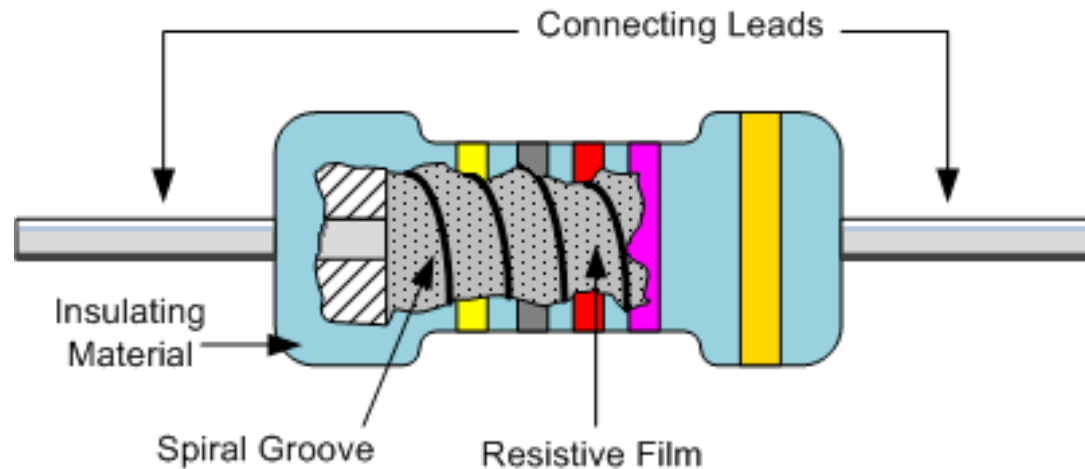

Example of Resistor Design

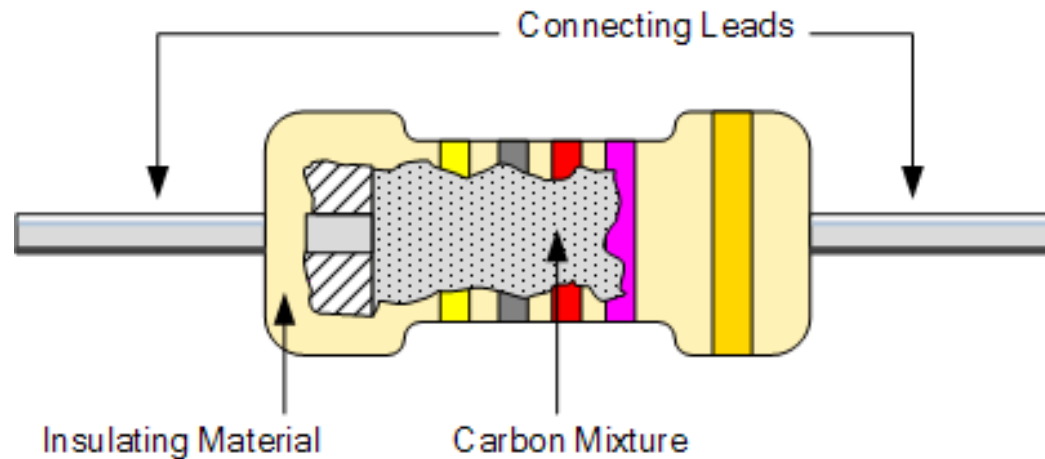

Example of Resistor Design

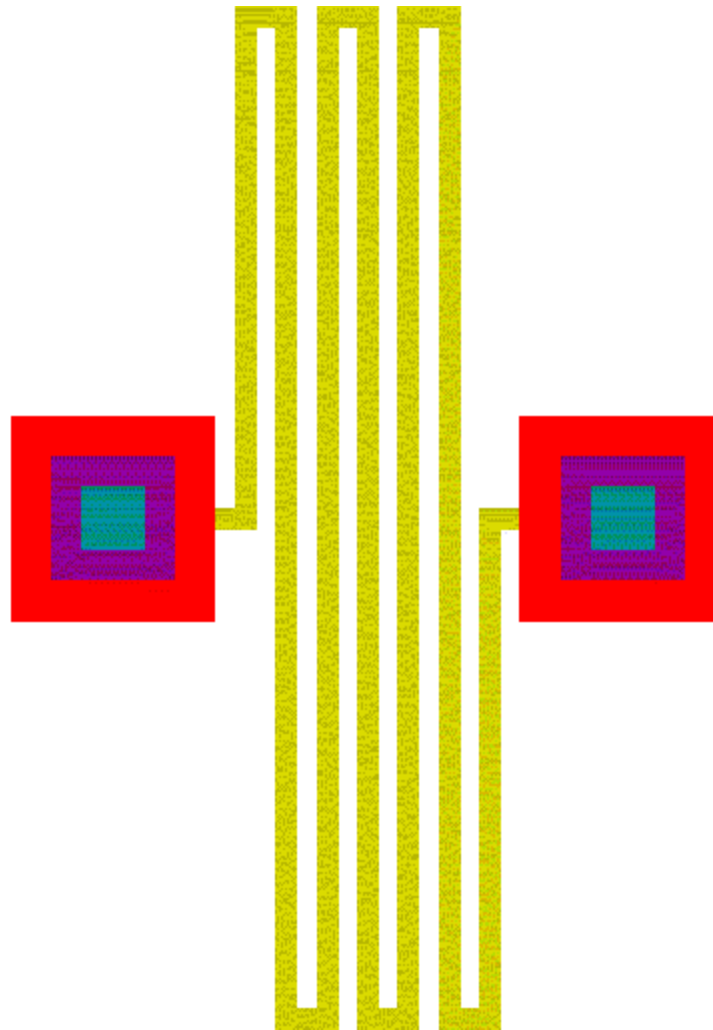

Graphic Representation of Resistor

Resistors

zig-zag
(USA, Japan)

rectangular
(Europe)



fixed resistor



variable resistor



continuous resistor



pre-set resistor



potentiometer



pre-set potentiometer



Example of Graphic Representations

Fixed Resistor



Variable Resistor

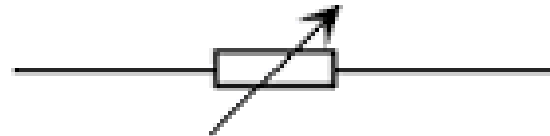

Thermistor



Thermistors are constructed of semiconductor material with a resistivity that is especially sensitive to temperature

Light Dependant Resistor (LDR)

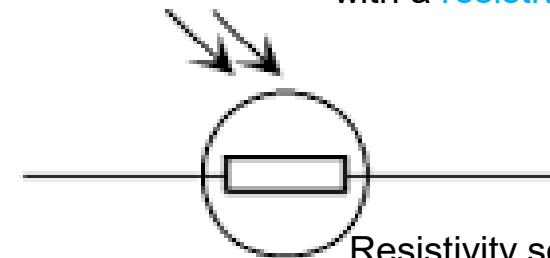

Resistivity sensitive to light

Definition of Resistance

- ▶ Electrical resistance measures the degree to which a resistor opposes an electric current passing through it.

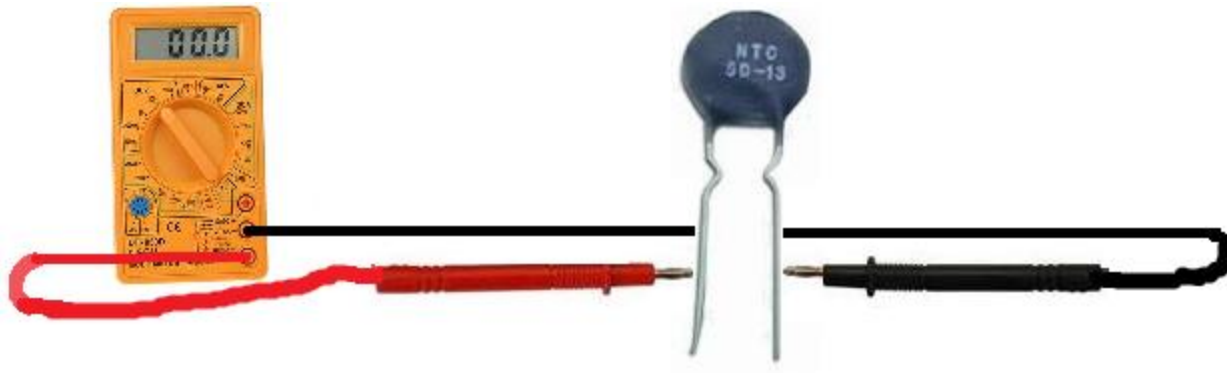

Example of Measuring Resistance



RESISTANCE: Measure this with the component **NOT** connected to the circuit.

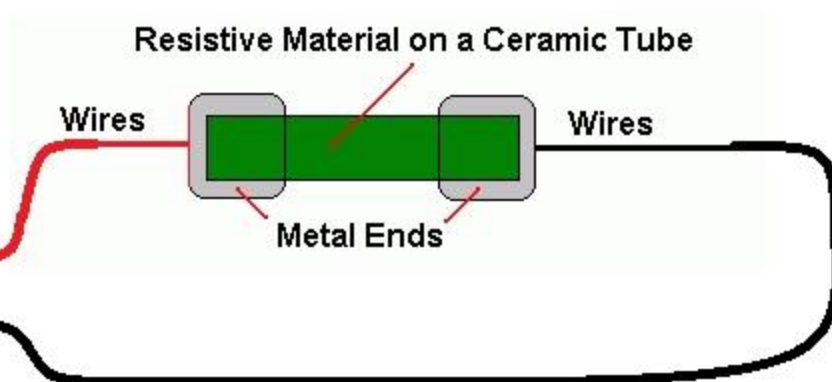

Unit of Measurement of Resistance

- The unit of measurement of resistance is Ohms.

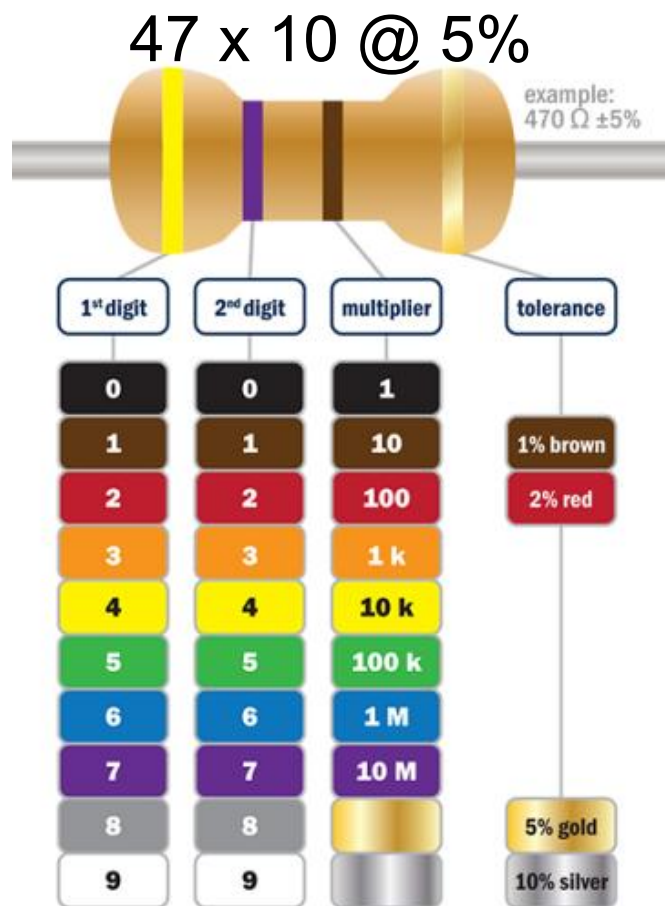

Resistor's Colour Code Chart

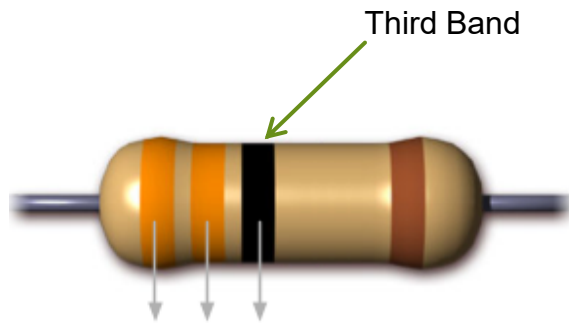

Match the **third band** to a chart below.
Then match the **first two bands** and read the value.

0	0	Ω
1	1	Ω
2	2	Ω
3	3	Ω
4	4	Ω
5	5	Ω
6	6	Ω
7	7	Ω
8	8	Ω
9	9	Ω

0	00	Ω
1	10	Ω
2	20	Ω
3	30	Ω
4	40	Ω
5	50	Ω
6	60	Ω
7	70	Ω
8	80	Ω
9	90	Ω

0	.0	kΩ
1	.1	kΩ
2	.2	kΩ
3	.3	kΩ
4	.4	kΩ
5	.5	kΩ
6	.6	kΩ
7	.7	kΩ
8	.8	kΩ
9	.9	kΩ

0	0	kΩ
1	1	kΩ
2	2	kΩ
3	3	kΩ
4	4	kΩ
5	5	kΩ
6	6	kΩ
7	7	kΩ
8	8	kΩ
9	9	kΩ

0	00	kΩ
1	10	kΩ
2	20	kΩ
3	30	kΩ
4	40	kΩ
5	50	kΩ
6	60	kΩ
7	70	kΩ
8	80	kΩ
9	90	kΩ

0	.0	MΩ
1	.1	MΩ
2	.2	MΩ
3	.3	MΩ
4	.4	MΩ
5	.5	MΩ
6	.6	MΩ
7	.7	MΩ
8	.8	MΩ
9	.9	MΩ

0	0	MΩ
1	1	MΩ
2	2	MΩ
3	3	MΩ
4	4	MΩ
5	5	MΩ
6	6	MΩ
7	7	MΩ
8	8	MΩ
9	9	MΩ

Example of Reading Resistor's Colour Codes

0	0	Ω
1	1	Ω
2	2	Ω
3	3	Ω
4	4	Ω
5	5	Ω
6	6	Ω
7	7	Ω
8	8	Ω
9	9	Ω

0	00	Ω
1	10	Ω
2	20	Ω
3	30	Ω
4	40	Ω
5	50	Ω
6	60	Ω
7	70	Ω
8	80	Ω
9	90	Ω

0	.0	kΩ
1	.1	kΩ
2	.2	kΩ
3	.3	kΩ
4	.4	kΩ
5	.5	kΩ
6	.6	kΩ
7	.7	kΩ
8	.8	kΩ
9	.9	kΩ

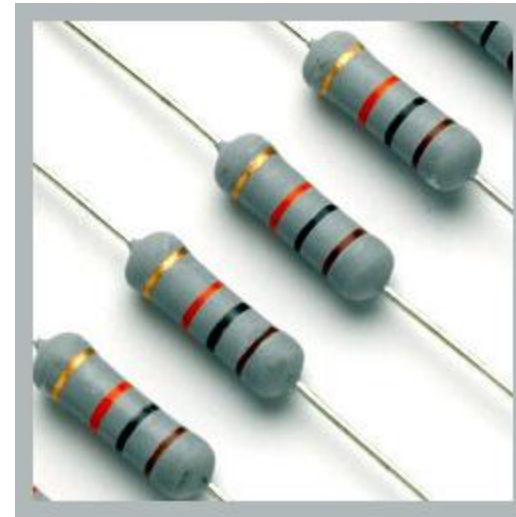

1K RESISTOR (+/-)5%

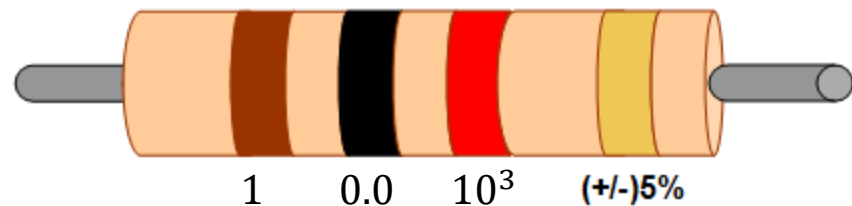

Match the Third Band First

Resistors Could Be Connected in Series

Calculation:

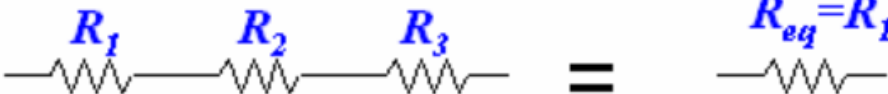
Series:  $R_{eq} = R_1 + R_2 + R_3$

Example:

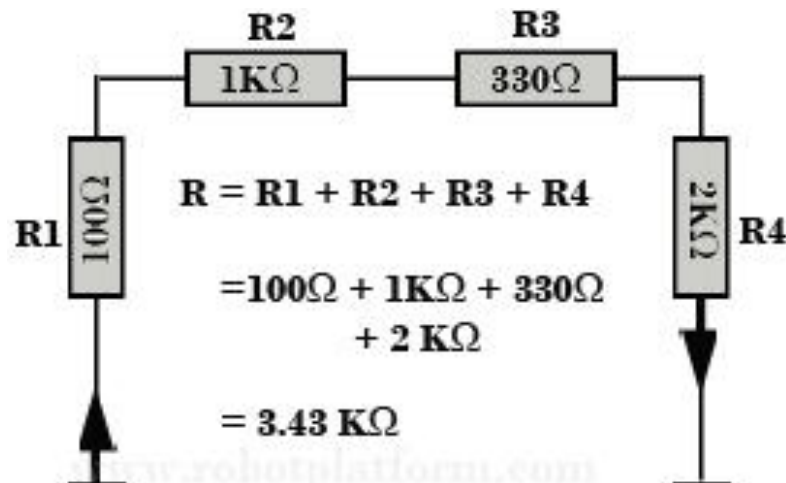

Resistors Could Be Connected in Parallel

Calculation:

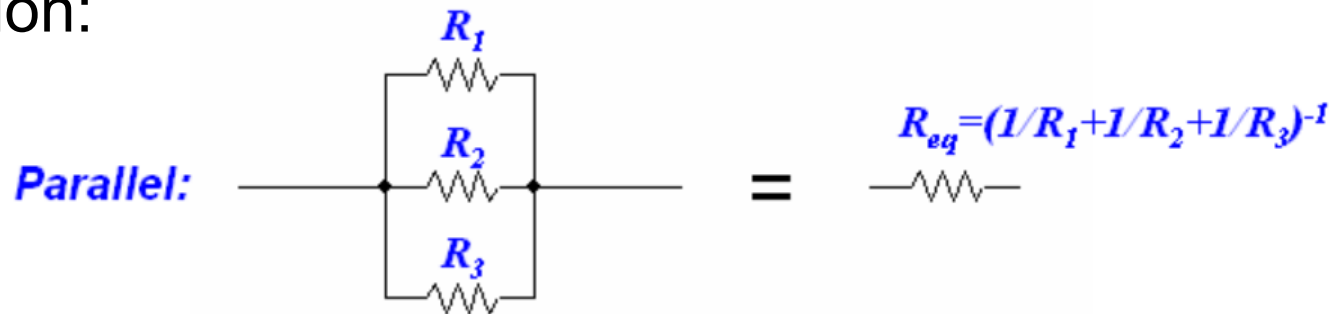

Example:

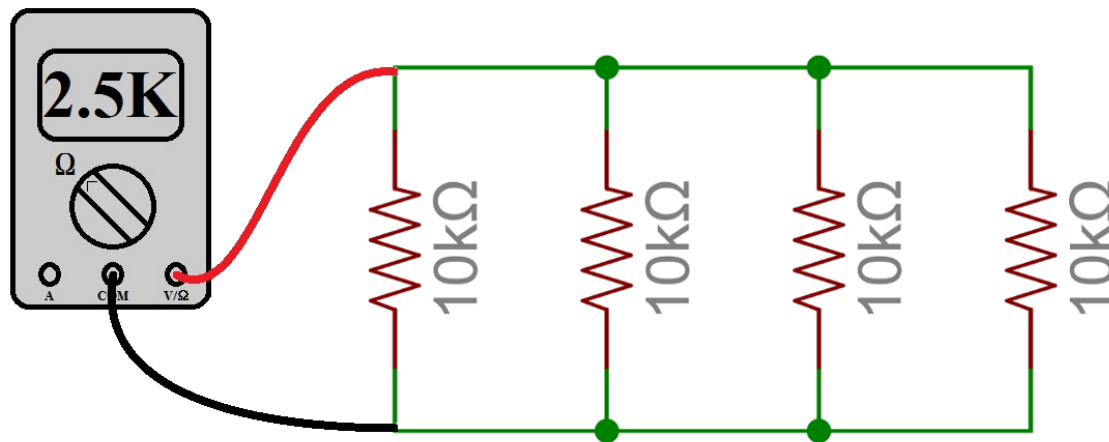

Total Resistance = Value of One Resistor / Number of Resistors
 $2.5K = 10K / 4$

Outline

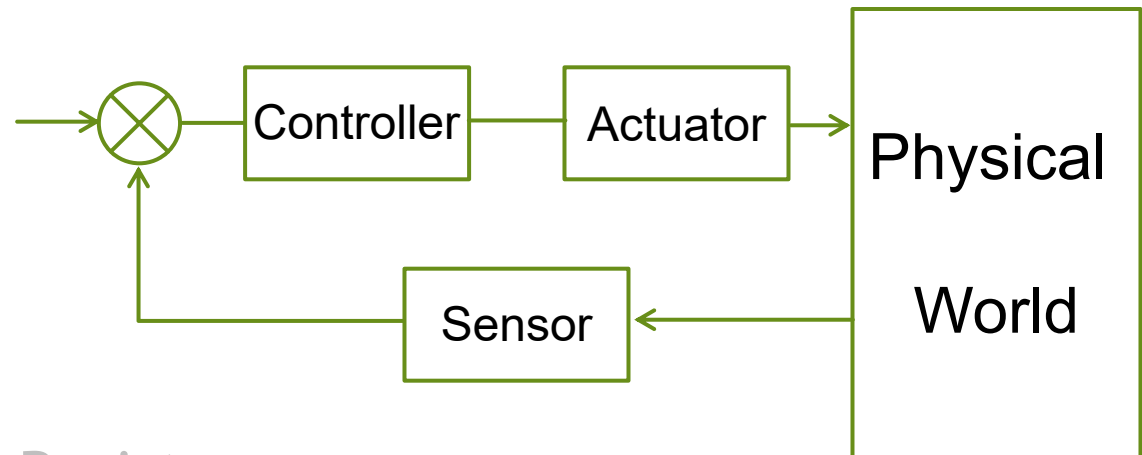

► Understanding of Resistance

► Computation of Resistance

► Measurement of Resistance

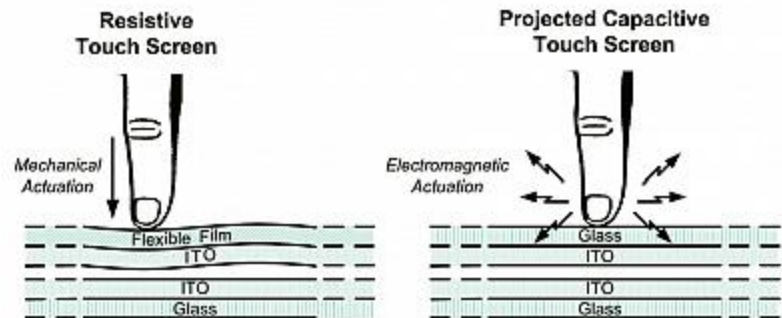

Resistor is a sensing element

Both **resistive** and **capacitive** technologies have a strong electrical component, both use ITO (Indium-Tin-Oxide, a clear conductor), and both will be around for a long time to come. A **resistive** touchscreen consists of a **flexible** top layer, then a layer of ITO (Indium-Tin-Oxide), an air gap and then another layer of ITO.

Ohm's Law for Resistor

$$I = \frac{V}{R}$$

$$di = \frac{dv}{R}$$

Time Domain

Frequency Domain

$$\frac{I(s)}{V(s)} = \frac{1}{R}$$

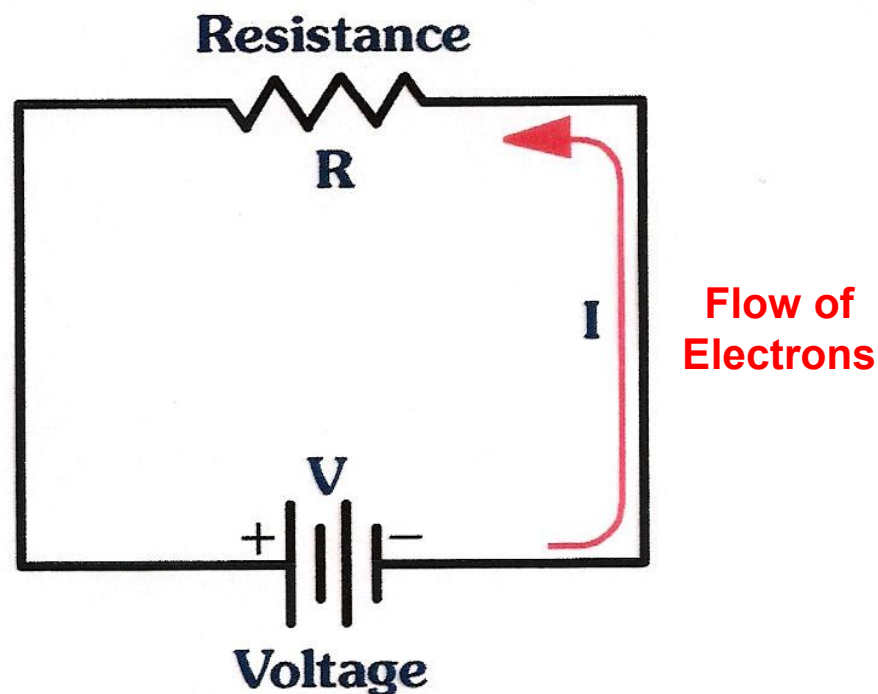

Example

- ▶ In the circuit as shown in the figure, when the voltage output varies 0.2 volts, the current changes 0.1 amperes. What is the resistance?
- ▶ Answer:

$$di = \frac{dv}{R}$$

$$R = \frac{dv}{di} = \frac{0.2}{0.1} = 2\Omega$$

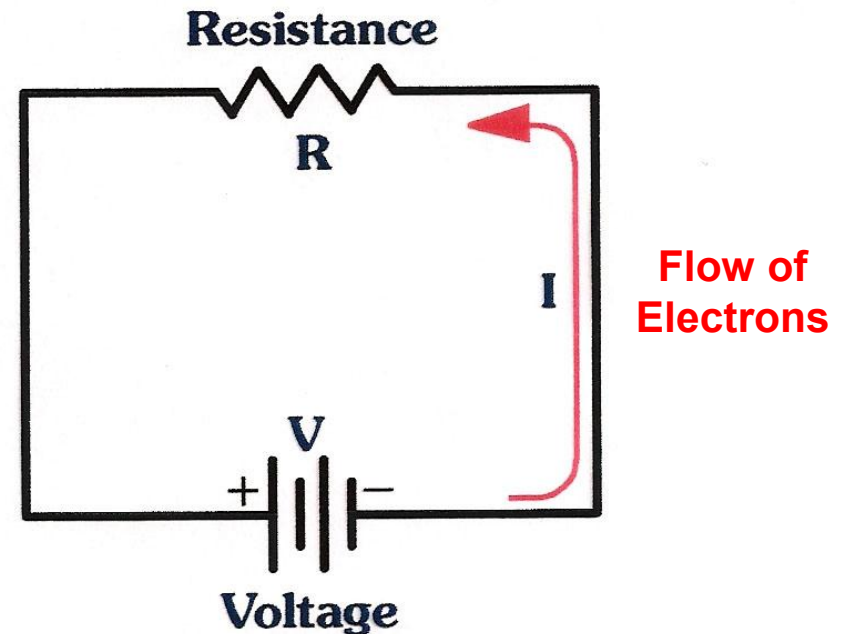

Alternating Current (AC) Circuit with Resistor

► Diagram:

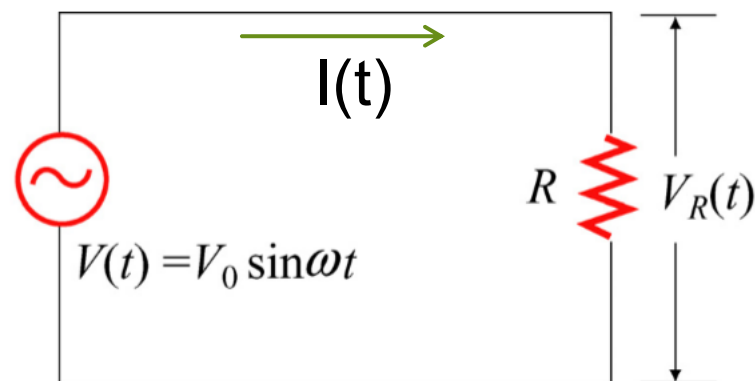
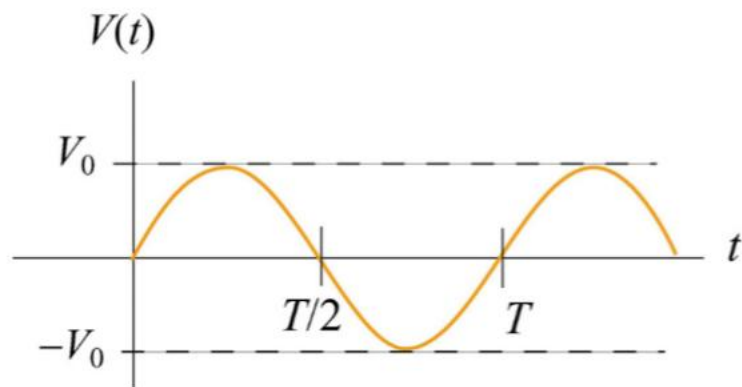

$$\omega = 2\pi f \quad \omega = \frac{2\pi}{T}$$

Equations of AC Circuit with Resistor

- Kirchhoff's Voltage Rule:

$$V(t) - V_R(t) = 0$$

$$V(t) - I(t)R = 0$$

$$I(t) = \frac{V(t)}{R} = \frac{V_0}{R} \sin(\omega t)$$

$$I(t) = I_0 \sin(\omega t)$$

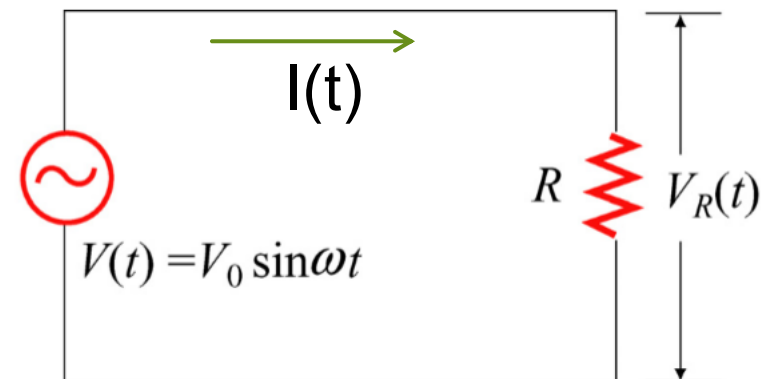
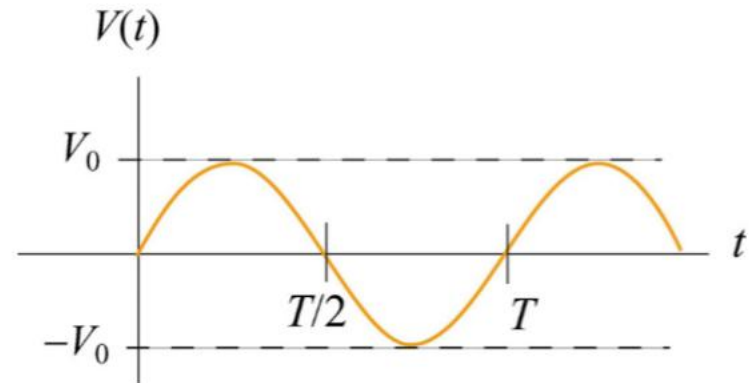

Property of LTI System: Sine input, Sine output

AC Circuit with Resistor

► Phasor Diagram:

$$I_{R0} = I_0 \quad V_{R0} = V_0$$

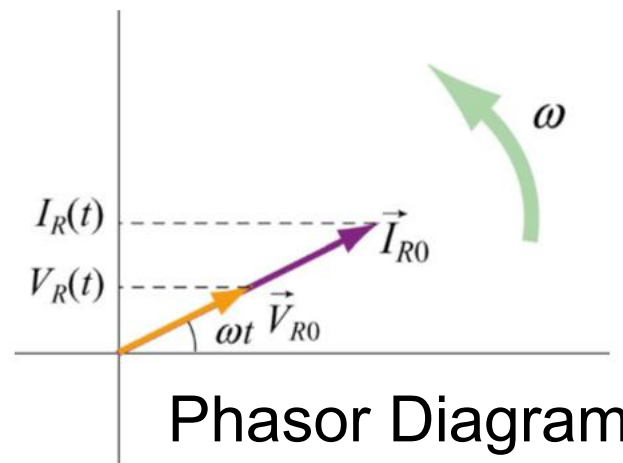
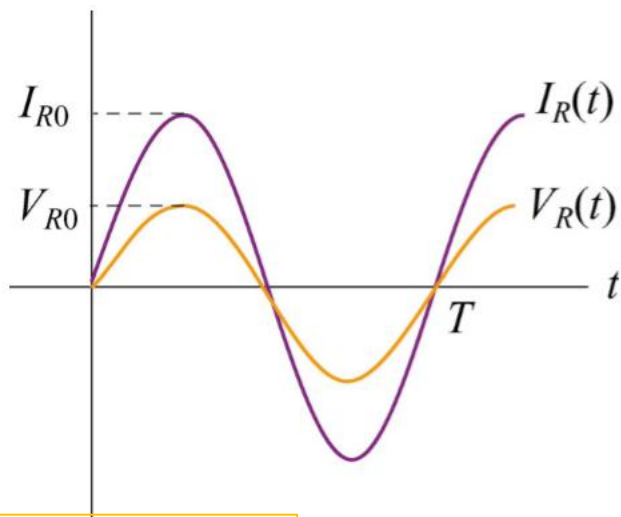
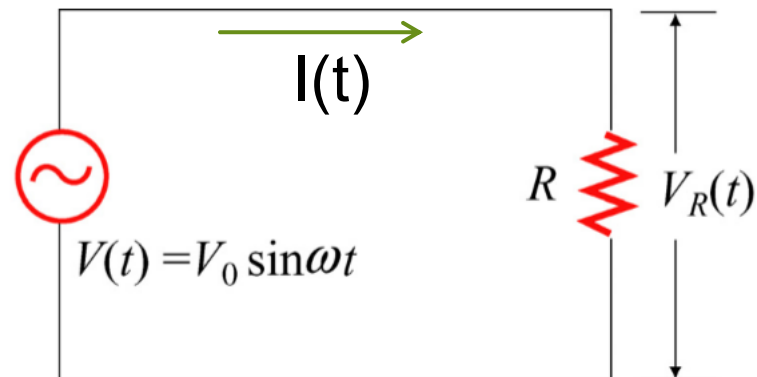

Peak Values

AC Circuit with Resistor

► Root-Mean-Square Voltage:

$$V_{rms} = \sqrt{\frac{1}{T} \int_0^T V_0^2 \sin^2(\omega t) dt} = \sqrt{\frac{1}{T} \int_0^T V_0^2 \sin^2\left(\frac{2\pi}{T} t\right) dt} = \frac{V_0}{\sqrt{2}}$$

$$V_0 = \sqrt{2} \times V_{rms}$$

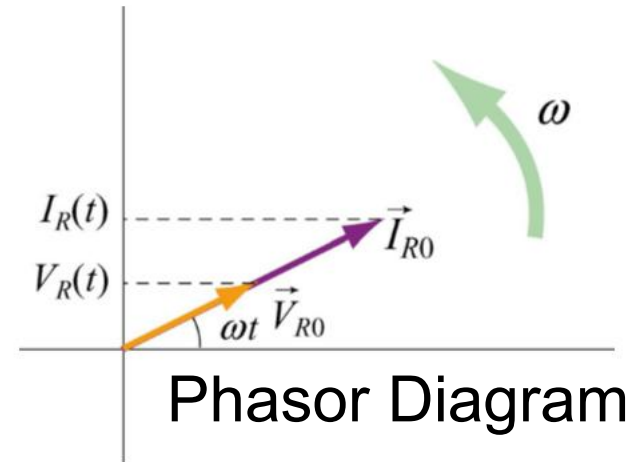
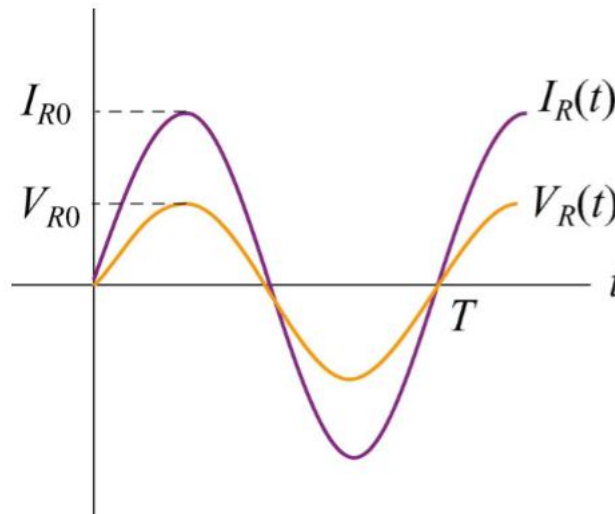
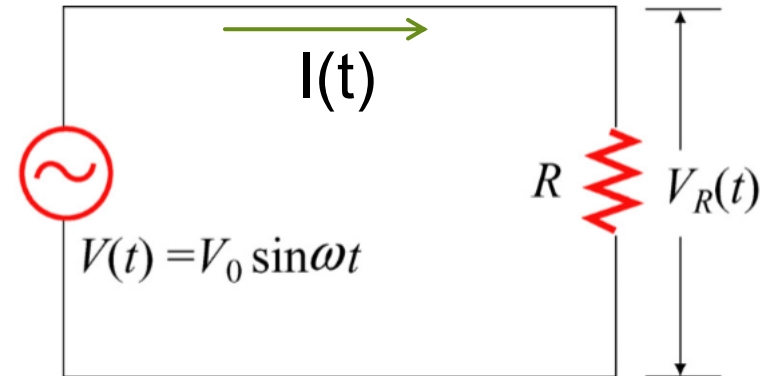

Peak Values

(RMS: Root Mean Square)

Current-Voltage Methods

- ▶ Z_x refers to the value of the electrical parameter of a resistor under measurement. R_{ref} is a resistor with a precise value of resistance.
- ▶ Hence, the value to be calculated is:

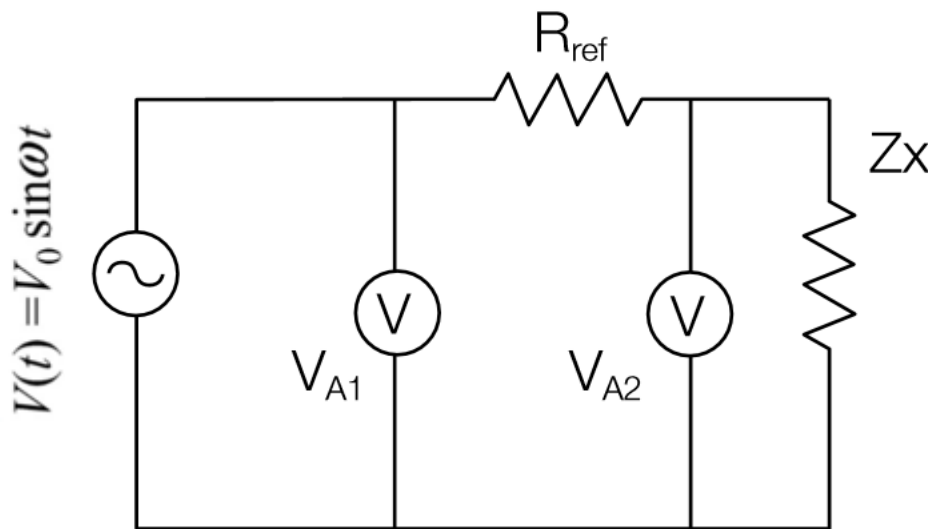

$$Z_X = \frac{V_{A2}}{I} = \frac{V_{A2}}{V_{A1} - V_{A2}} R_{ref}$$

Example of Calculating Resistance

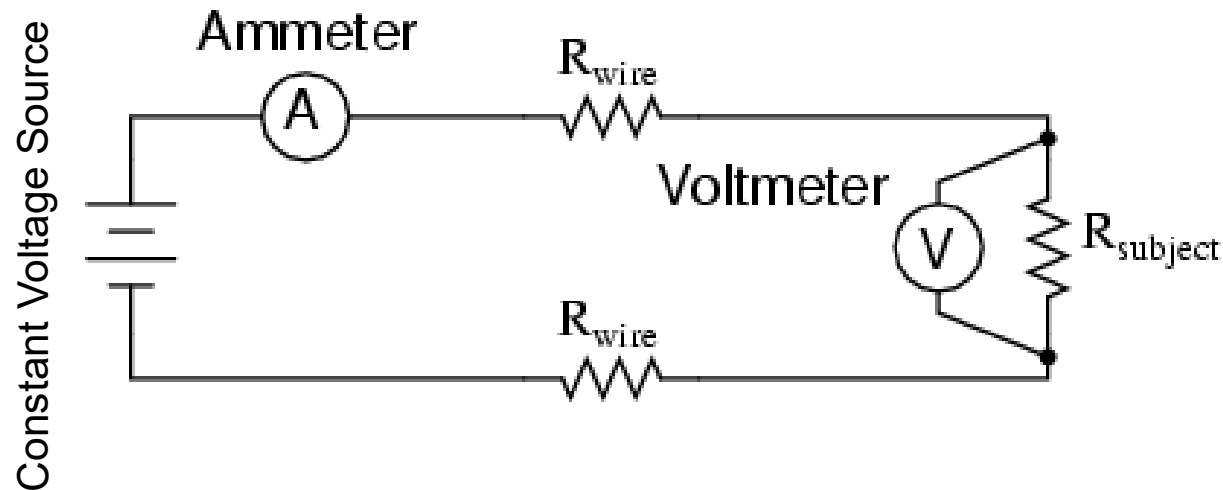

$$R_{\text{subject}} = \frac{\text{Voltmeter indication}}{\text{Ammeter indication}}$$

Example of Calculating Resistance

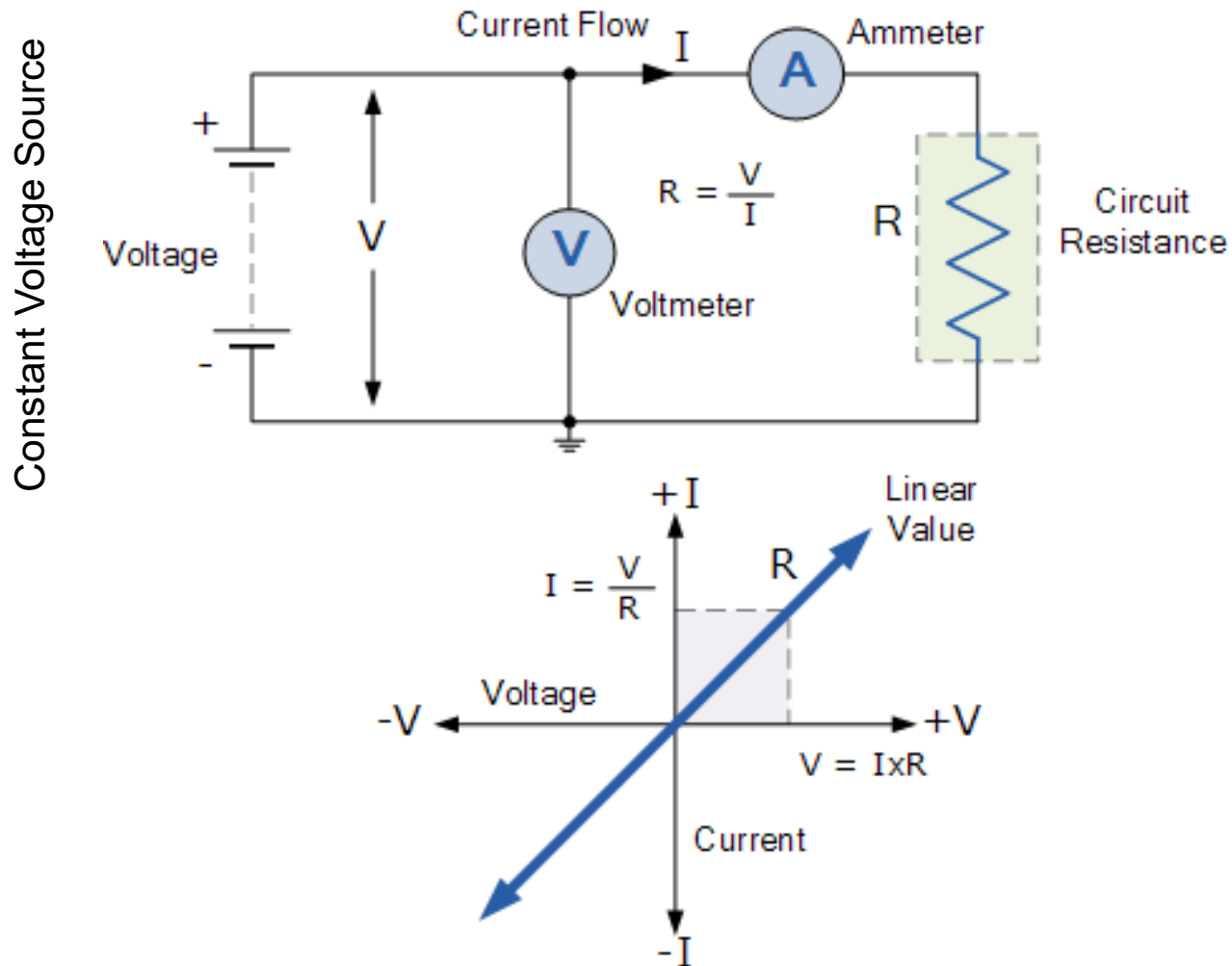

Example of Calculating Resistance

- ▶ What is the equation of calculating the resistance R_X as shown in the circuit below?

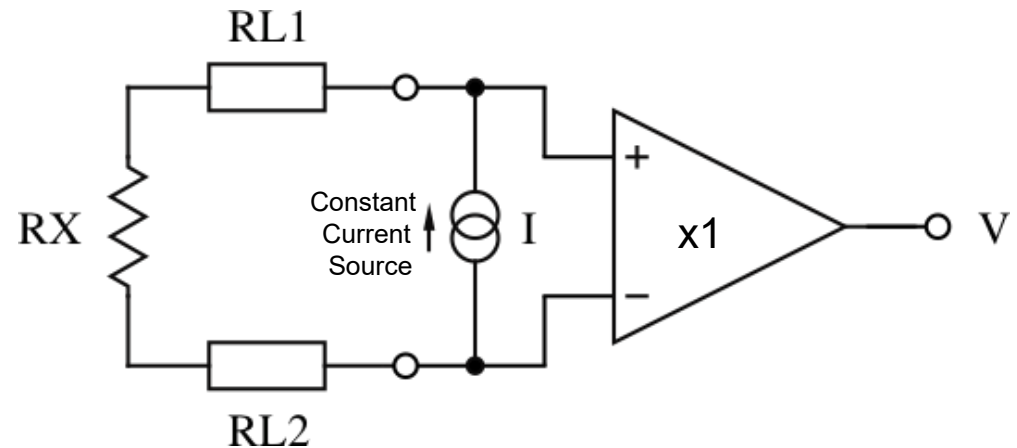

- ▶ Answer:

$$V = I \times (RL1 + RL2 + RX)$$

$$RX = \frac{V}{I} - RL1 - RL2$$

Bridge-Circuit Methods

- Four devices of resistor form a rectangle loop. A known power source is applied to one pair of diagonal points. The voltage output from another pair of diagonal points indicates the in-balance or out-of-balance of the bridge circuit.

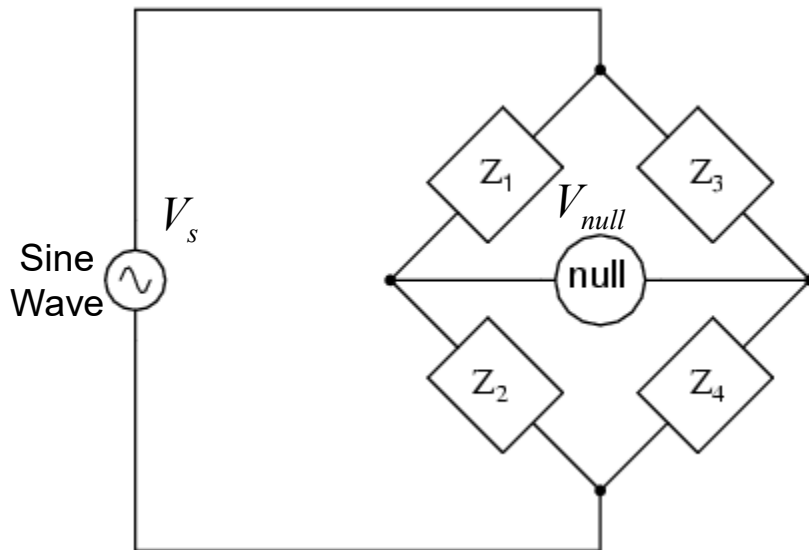

$$V_{null} = \frac{V_s}{Z_1 + Z_2} Z_2 - \frac{V_s}{Z_3 + Z_4} Z_4$$

$$0 = \frac{V_s}{Z_1 + Z_2} Z_2 - \frac{V_s}{Z_3 + Z_4} Z_4$$

$$\frac{Z_2}{Z_1 + Z_2} = \frac{Z_4}{Z_3 + Z_4}$$

Example of Using Bridge-Circuit

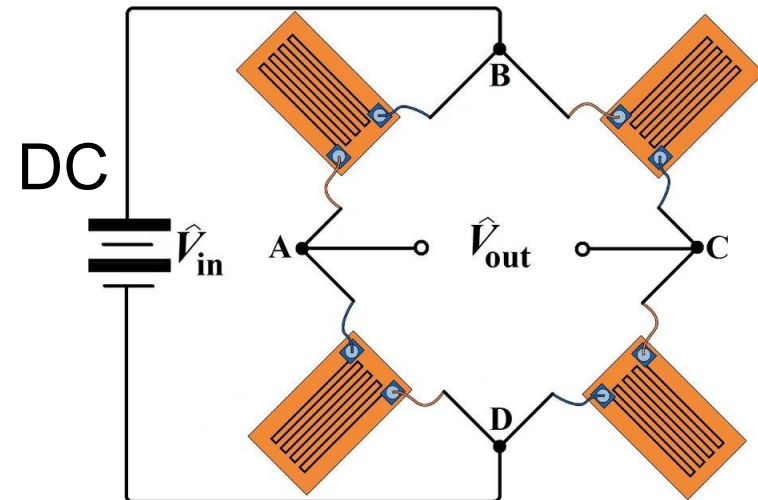
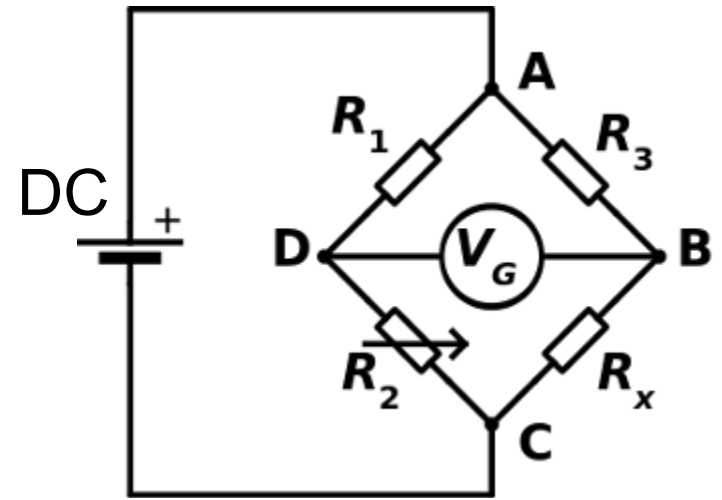
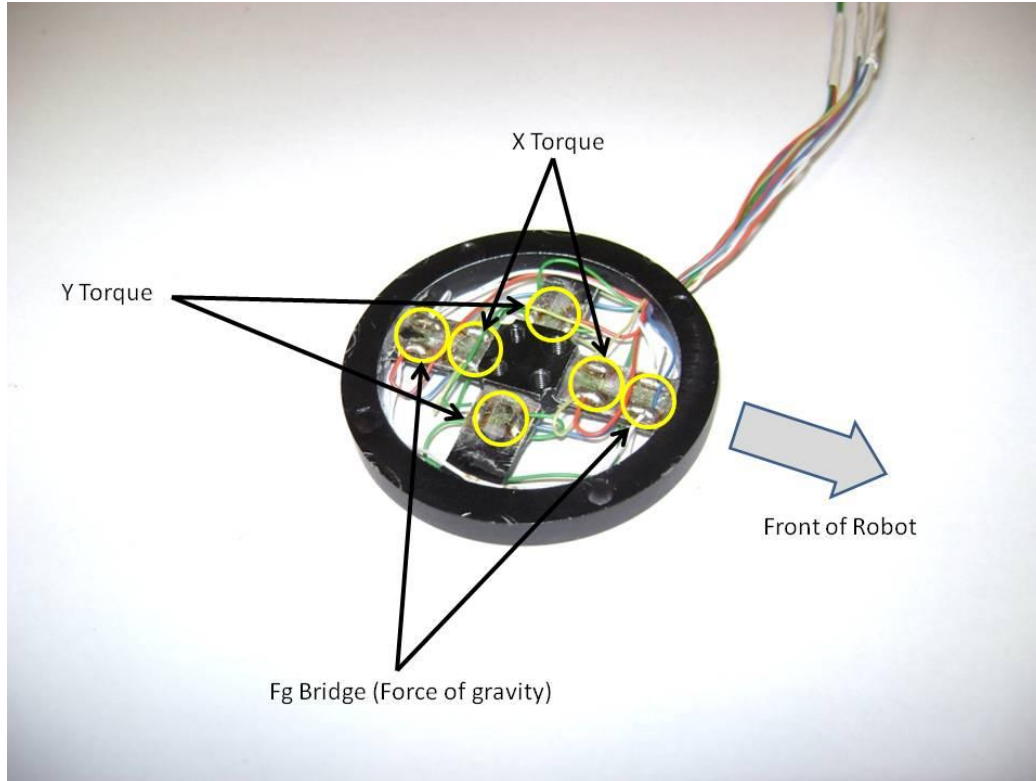

$$\frac{R_2}{R_1 + R_2} = \frac{R_x}{R_3 + R_x}$$

Example of Calculating Resistance

- ▶ As shown in the figure below, if $V_1 = V_2 = 1.2$ volts, what is the resistance of the resistor under measurement?

- ▶ Answer:

$$I_{R3} = \frac{3.0 - 1.2}{10 \times 10^3} \text{ amperes}$$

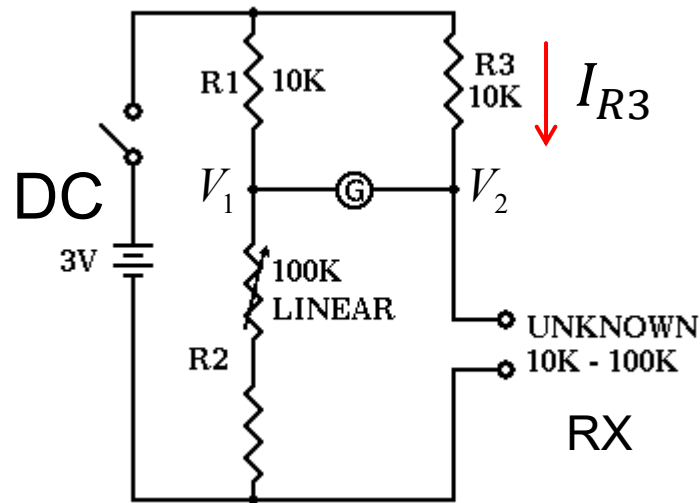

$$R_{unknown} = \frac{V_2}{I_{R3}} = \frac{10 \times 10^3}{3.0 - 1.2} \times 1.2 = 6.67 K\Omega$$

Outline

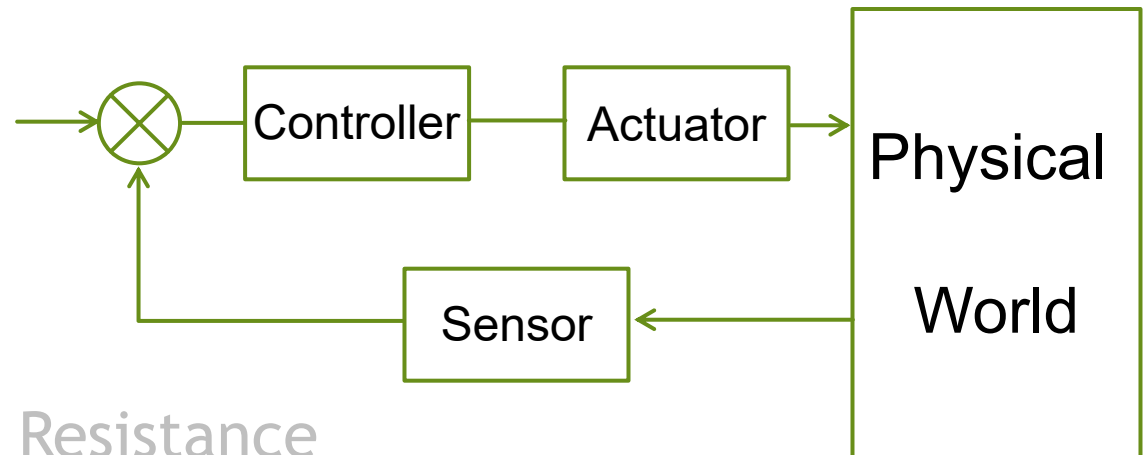

- ▶ Understanding of Resistance
- ▶ Computation of Resistance
- ▶ Measurement of Resistance

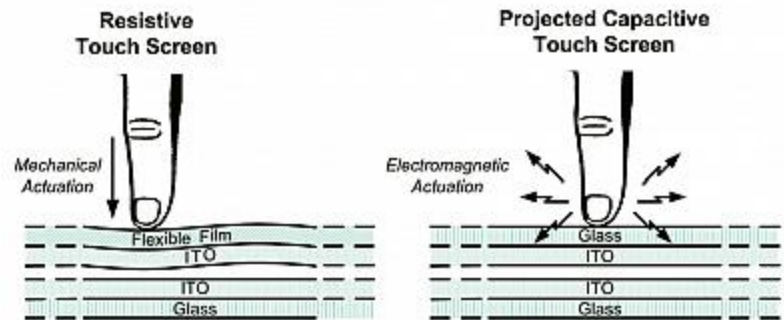

Resistor is a sensing element

Both **resistive** and **capacitive** technologies have a strong electrical component, both use ITO (Indium-Tin-Oxide, a clear conductor), and both will be around for a long time to come. A **resistive** touchscreen consists of a **flexible** top layer, then a layer of ITO (Indium-Tin-Oxide), an air gap and then another layer of ITO.

Applications: Resistive Touch Screens

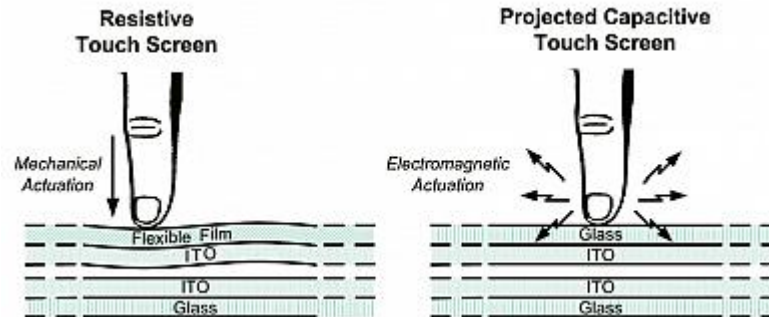

Resistor is a sensing element

Both **resistive** and **capacitive** technologies have a strong electrical component, both use ITO (Indium-Tin-Oxide, a clear conductor), and both will be around for a long time to come. A **resistive** touchscreen consists of a **flexible** top layer, then a layer of ITO (Indium-Tin-Oxide), an air gap and then another layer of ITO.

Applications: Constant Current Source

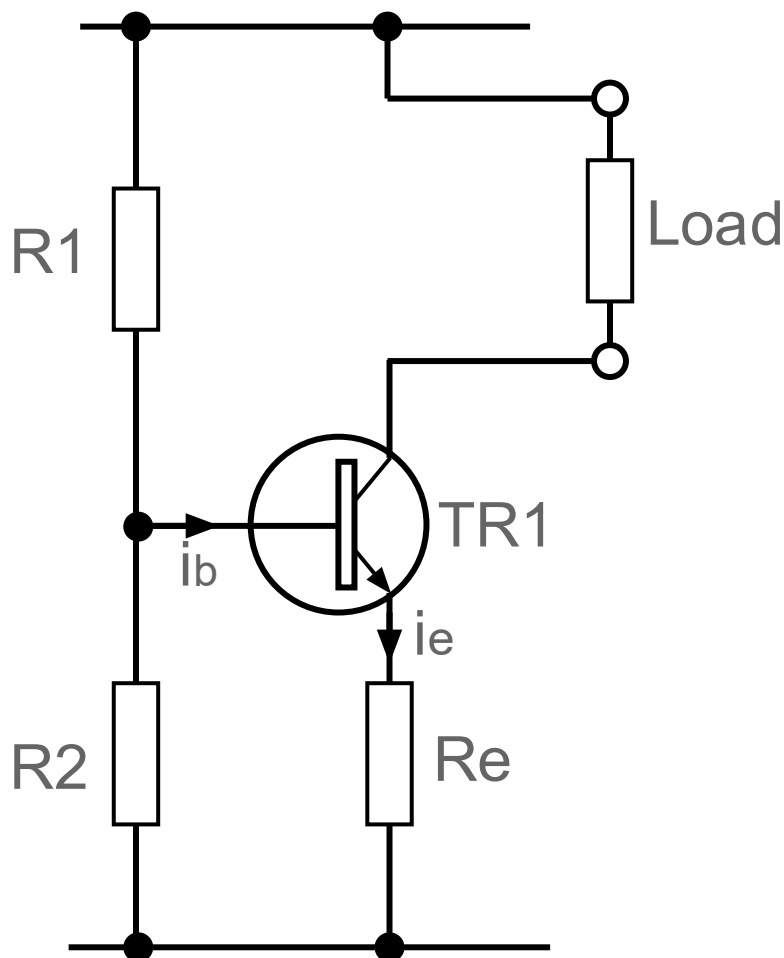

$$i_e = \left(\frac{v}{R_1 + R_2} R_2 - 0.7 \right) \frac{1}{R_e}$$

Applications: Potentiometer

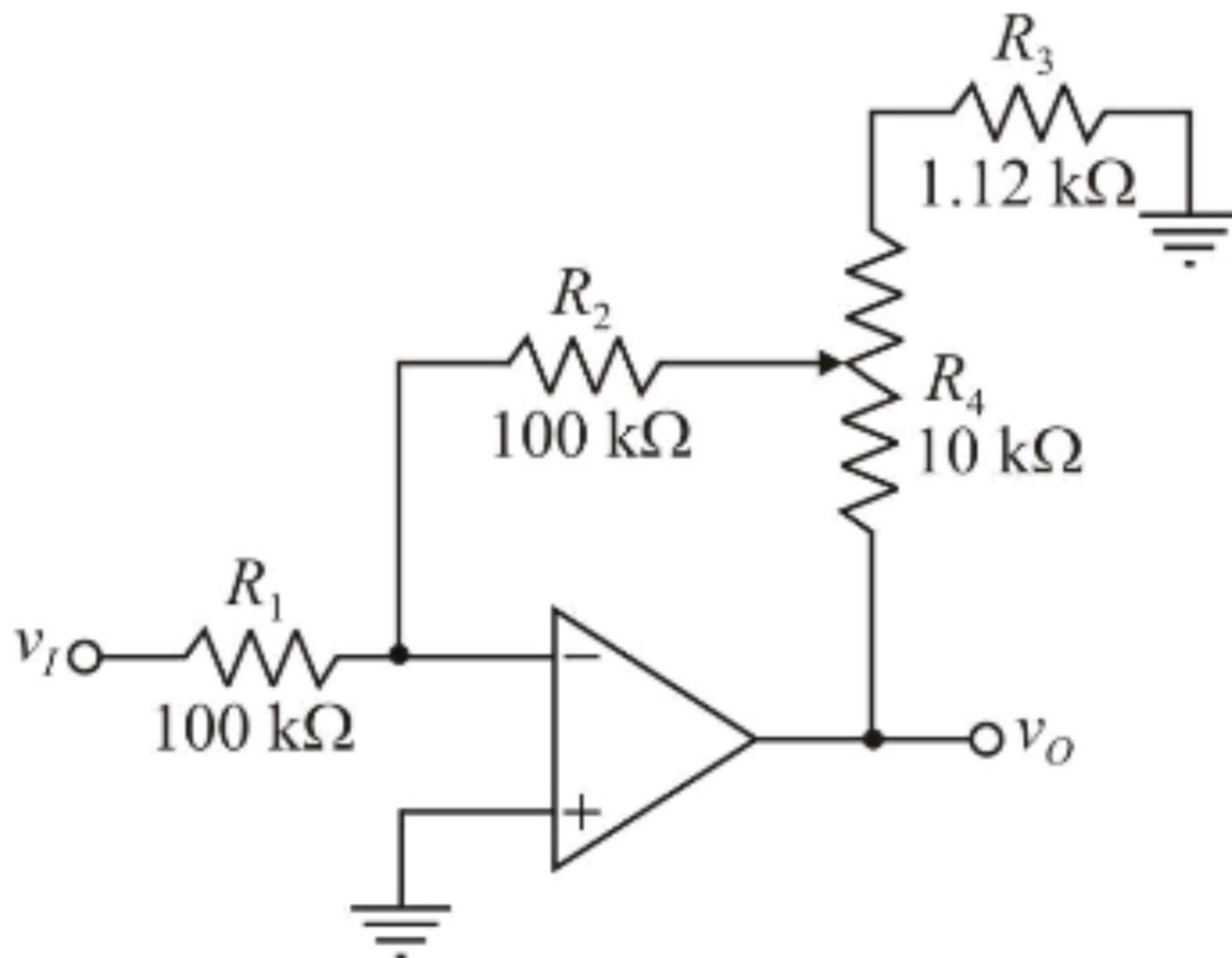

Applications: Force/Torque Sensors

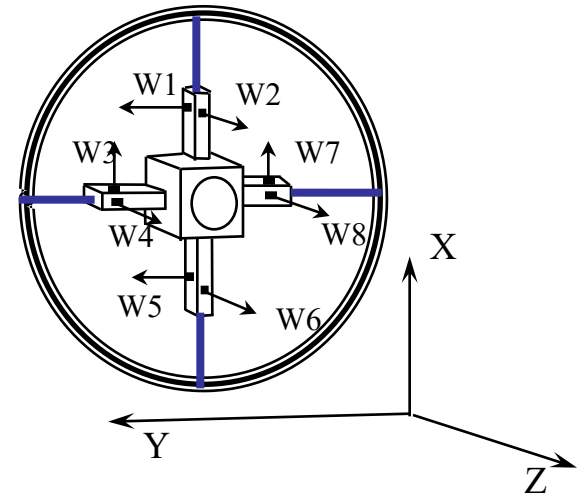
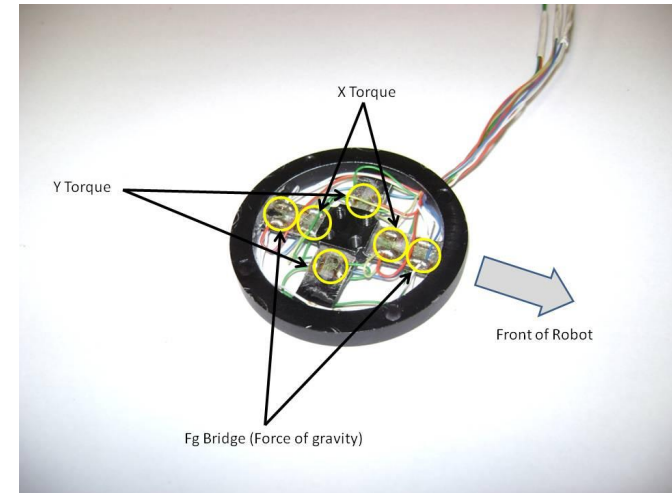
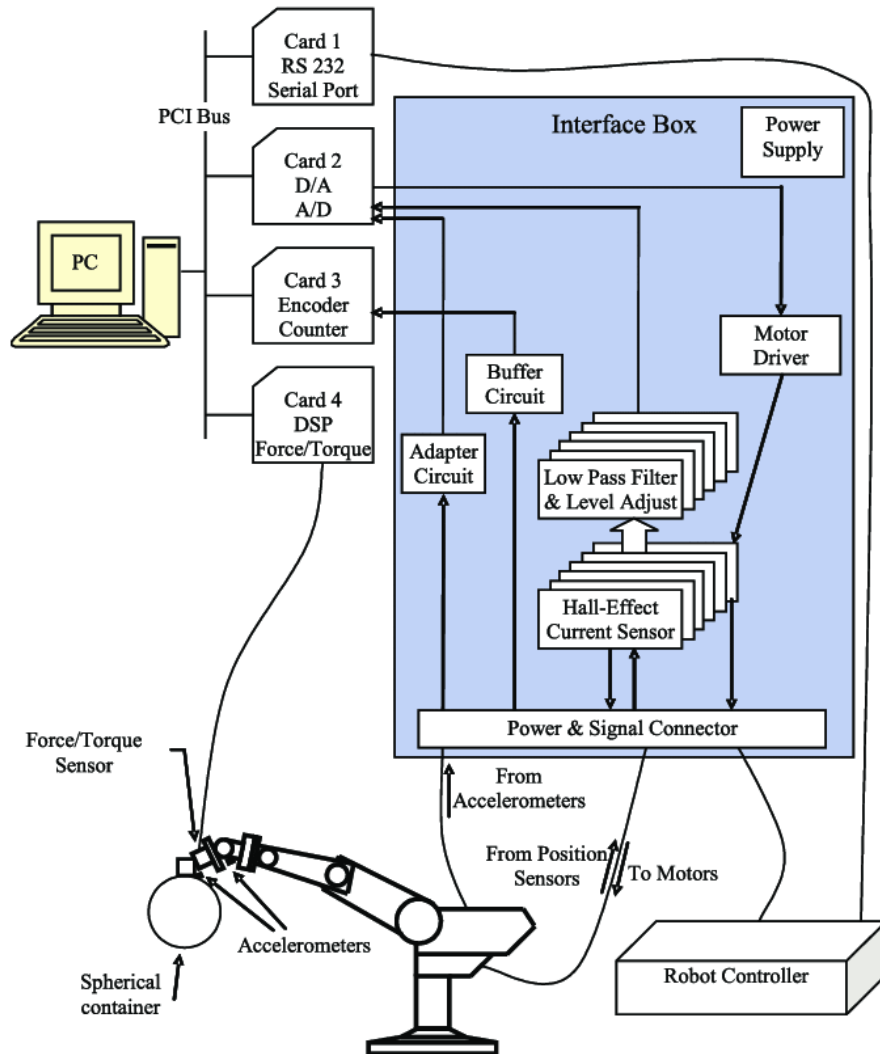

Principles of Measuring Resistance

- ▶ Electric voltage can be automatically measured.
- ▶ Electric current can be automatically measured.
- ▶ Electric resistance could be related to voltage or current.
- ▶ Hence, electric resistance can also be automatically measured.

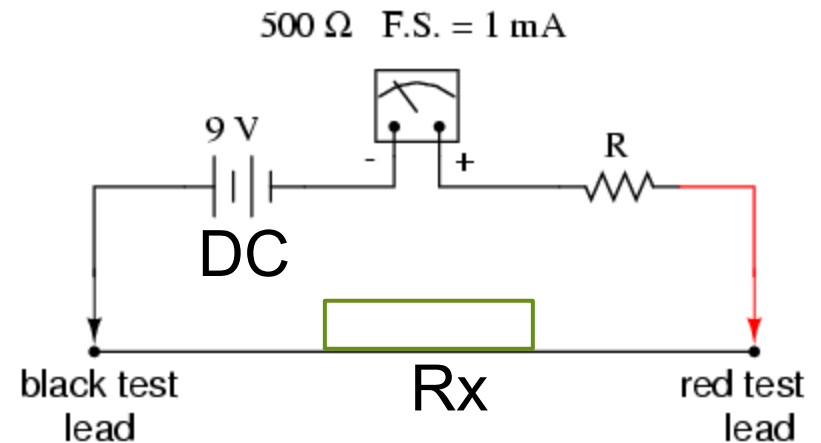

Example of Designing Analogue Measurement and Sensing Systems for Resistance

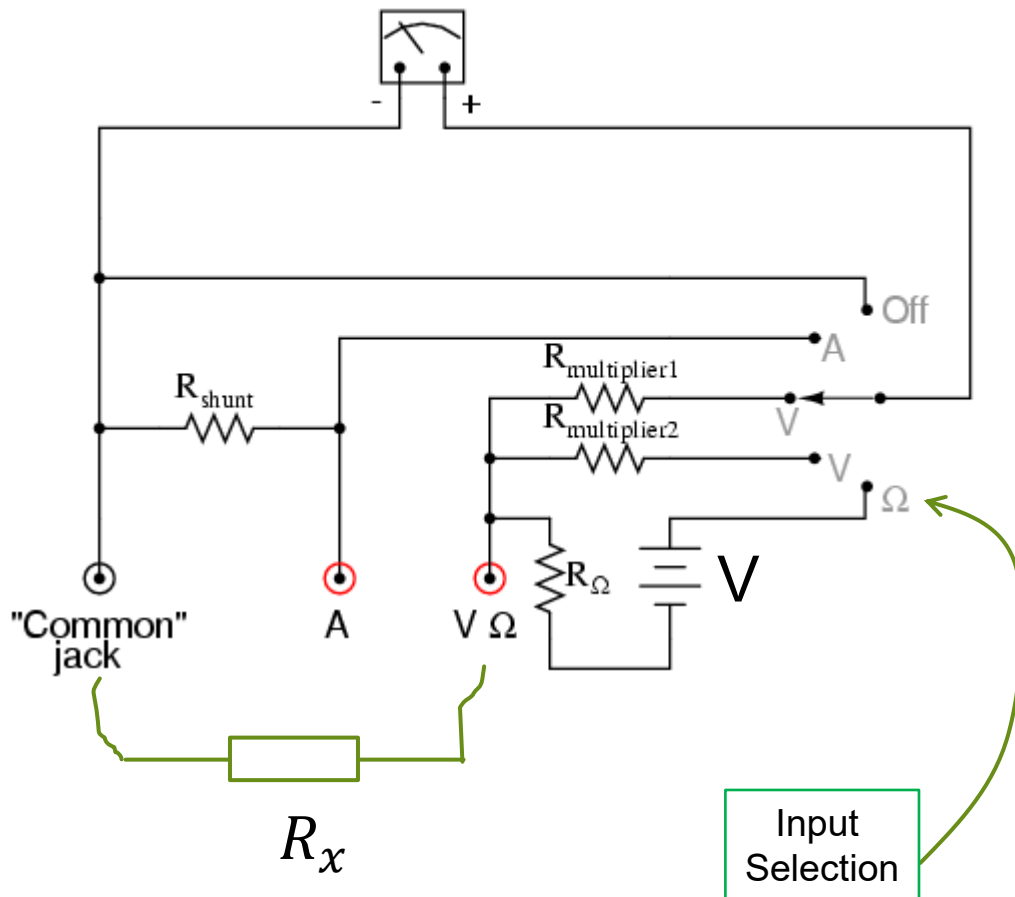

$$I = \frac{V}{R_{\Omega} + R_x}$$



$$R_x = \frac{V - I \times R_{\Omega}}{I}$$

Example of doing manual measurement

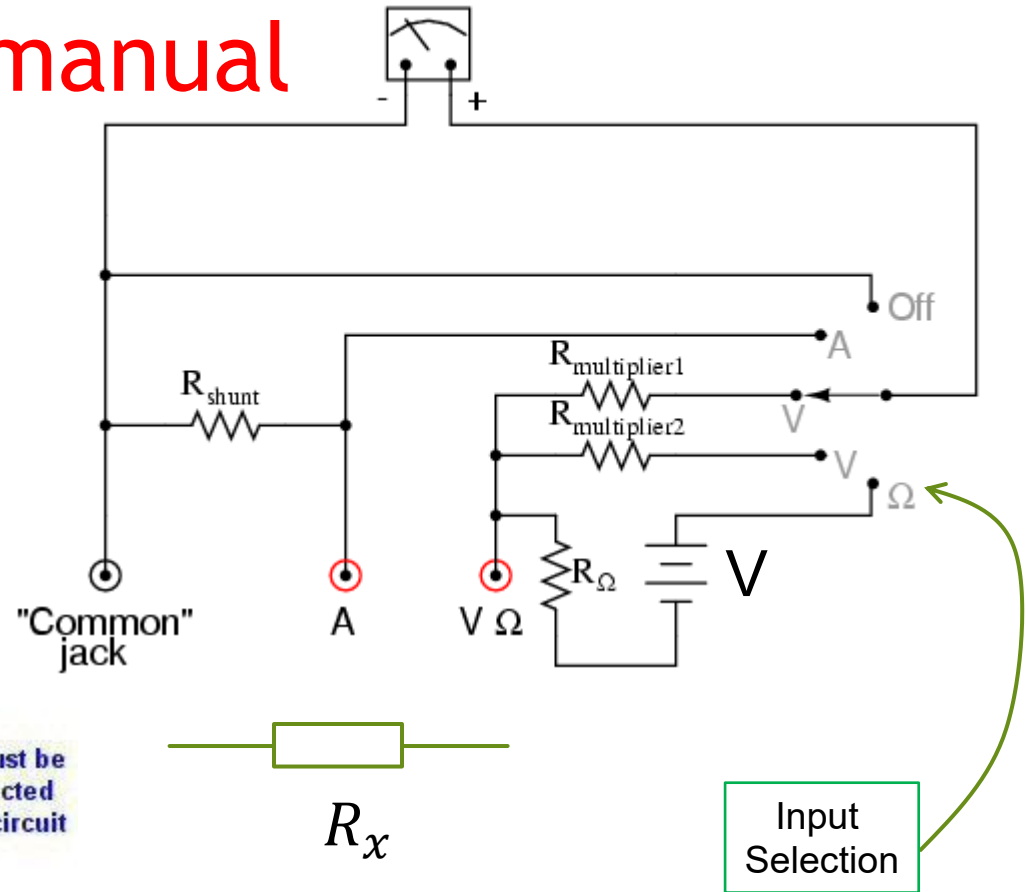
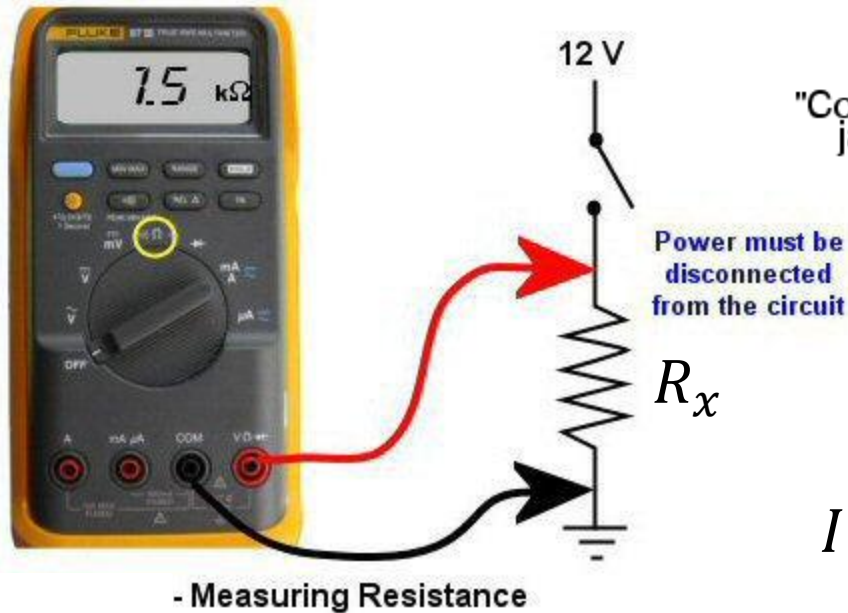

$$I = \frac{V}{R_{\Omega} + R_x} \quad \Rightarrow \quad R_x = \frac{V - I \times R_{\Omega}}{I}$$

How to design digital measurement and sensing systems for resistance?

- ▶ Resistance is converted to voltage which is measured by digital voltmeter (e.g. microcontrollers).

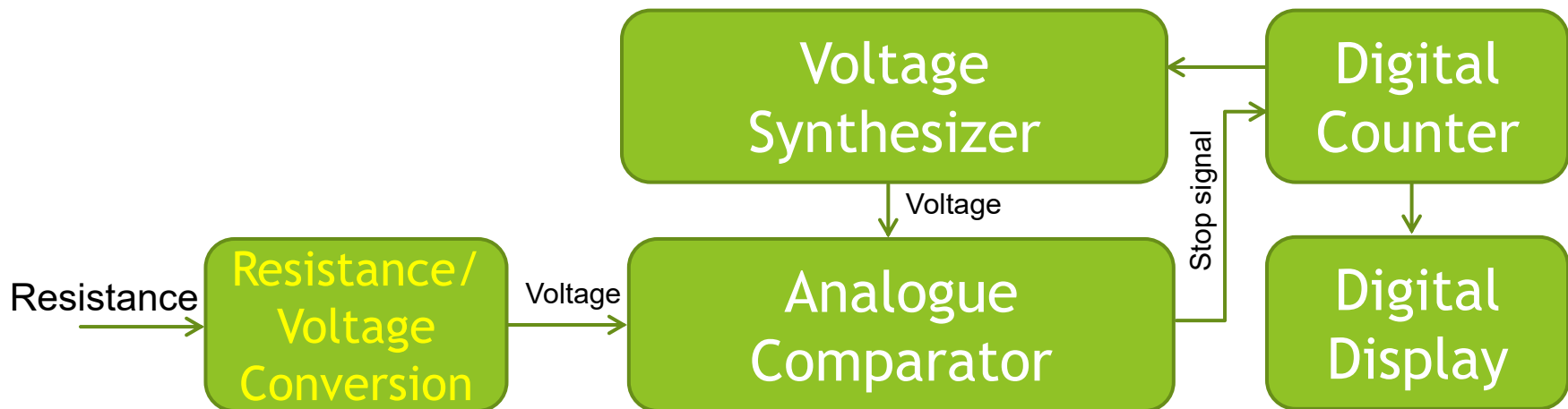

All microcontrollers are programmable digital sensors of voltage!

How to convert values of resistance into values of voltage?

- To use Wheatstone bridge circuit ...

$$V_{out} = \frac{V_{in}}{R_1 + R_3} R_3 - \frac{V_{in}}{R_2 + R_4} R_4$$

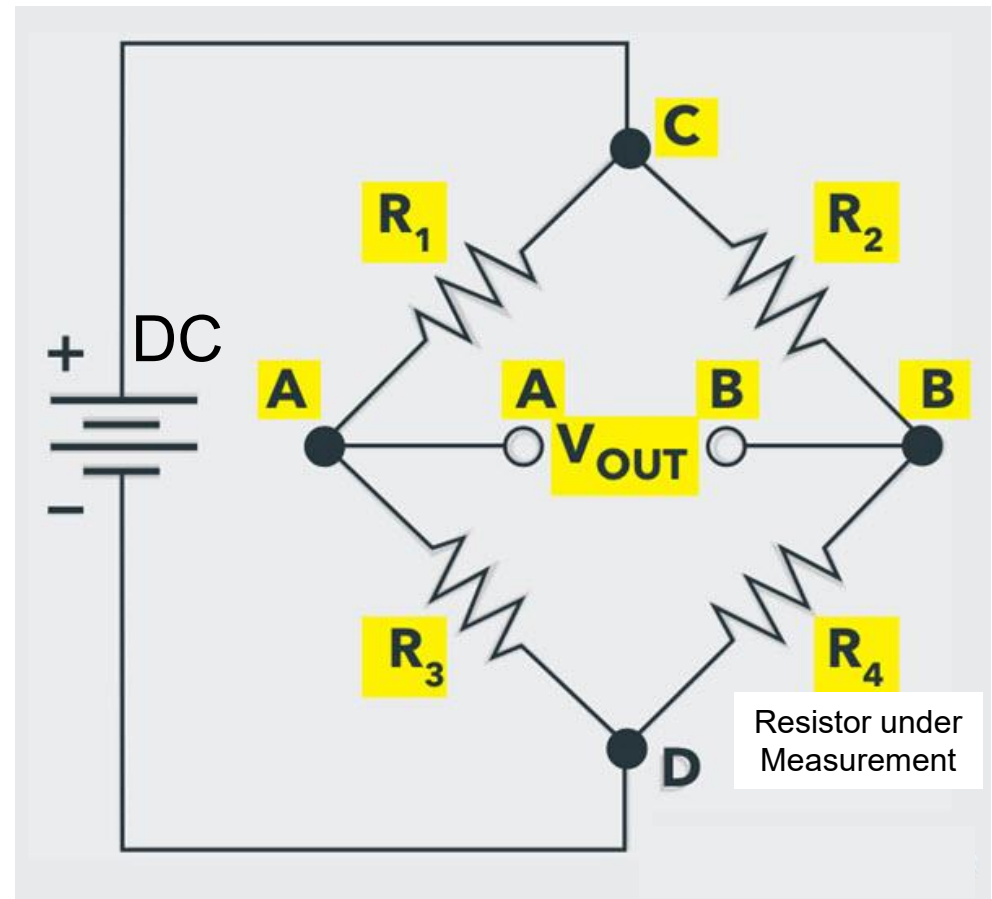

How to convert values of resistance into values of voltage? (continued)

► To use a circuit with constant current source ...

$$V_1 = R_2 \frac{V_{in}}{R_1 + R_2}$$

$$V_2 = V_1$$

$$V_{out} = V_{in} - R_2 \frac{V_{in}}{R_1 + R_2} \frac{R}{R_e}$$

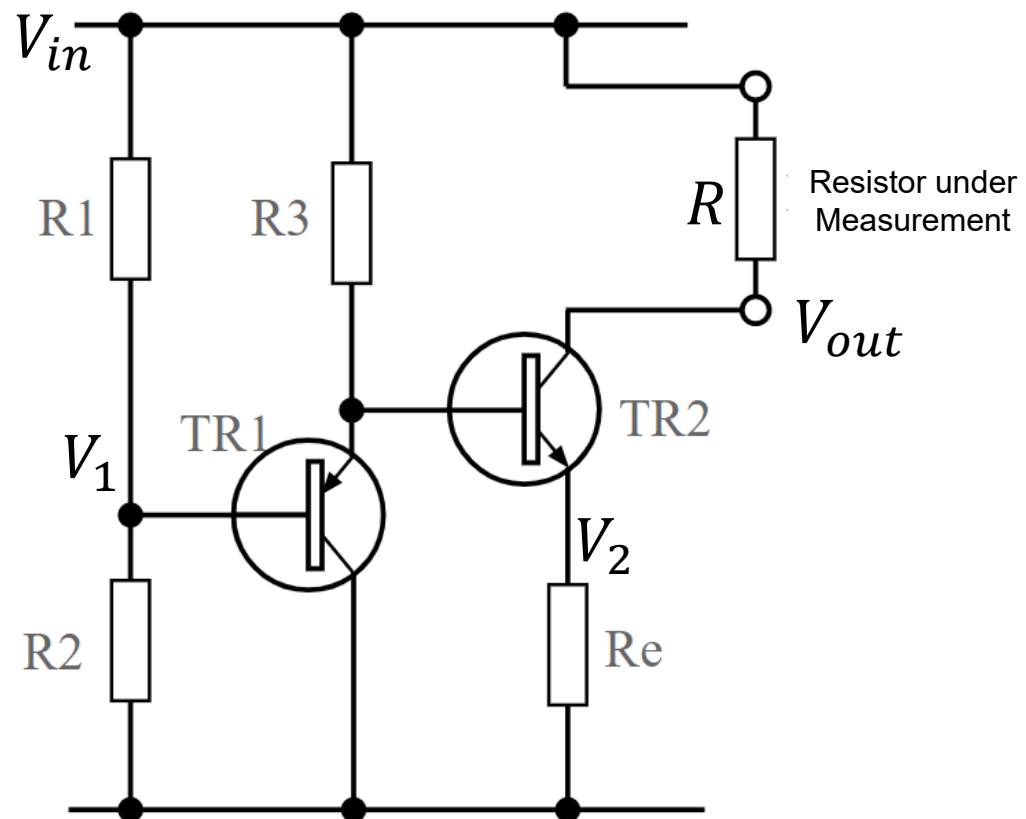

Remember to Do Calibration

- ▶ Curve fitting for calibration:
 - ▶ Y_i is produced by X_i
 - ▶ Z_i is computed from Y_i
 - ▶ Z_i must be equal to X_i

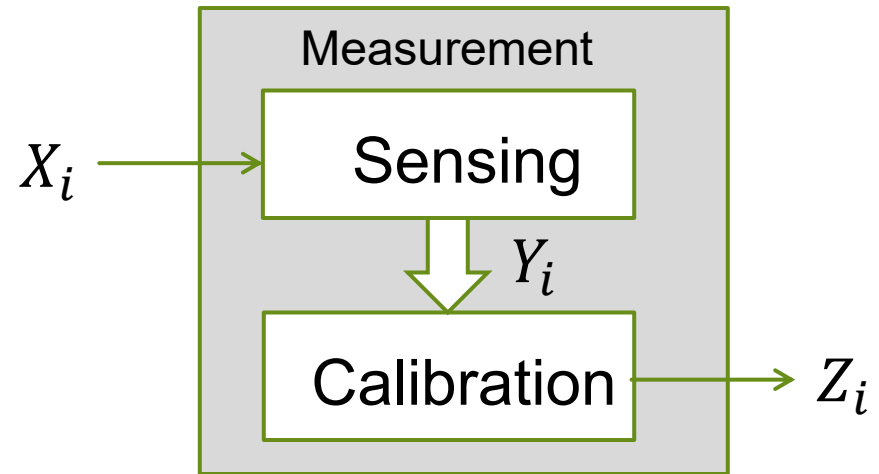

Calibrated Values Z_i

Measured Values Y_i

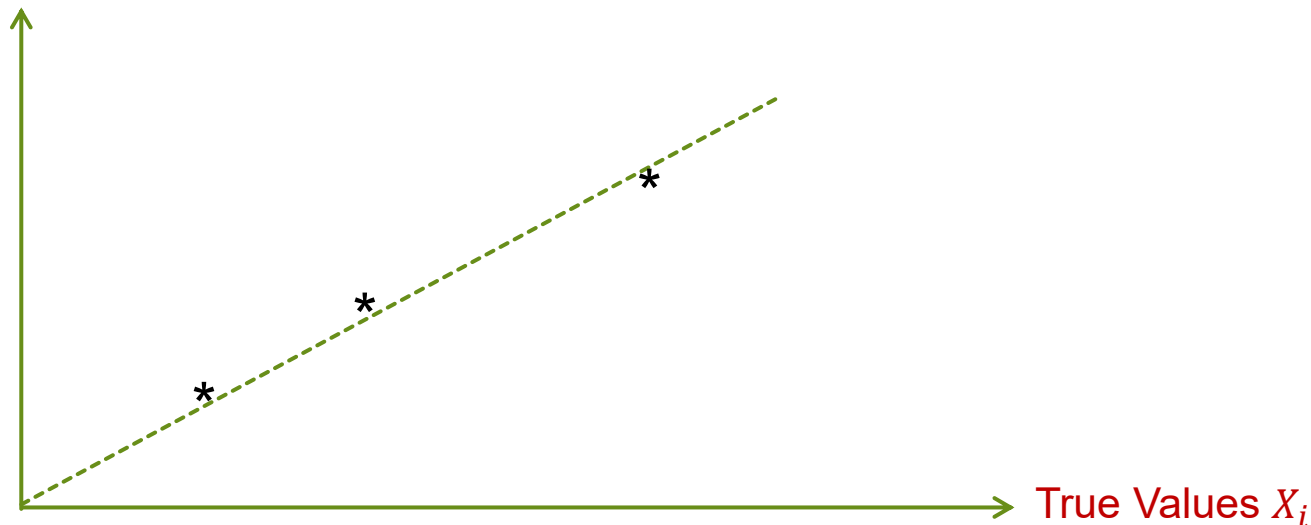

Remember to Do Error Analysis

- ▶ Systematic error = mean value - true value
- ▶ Repeatability error = value with maximum error - mean value
- ▶ Accuracy = value with minimum error - mean value
- ▶ Hysteresis error = |measured value in increasing - measured value in decreasing|

For each true value, we can do error analysis

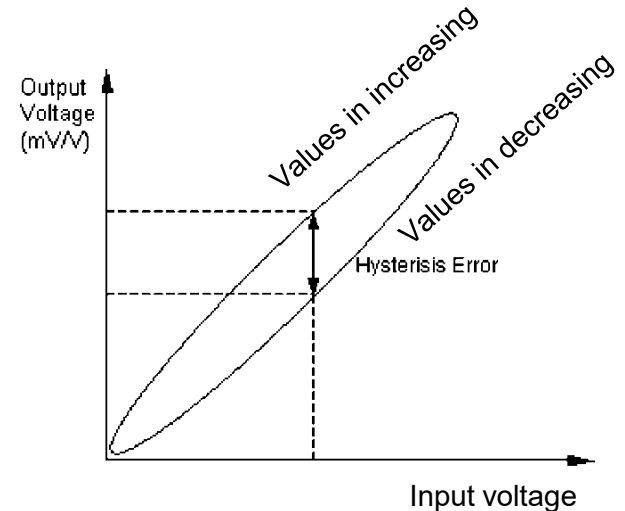
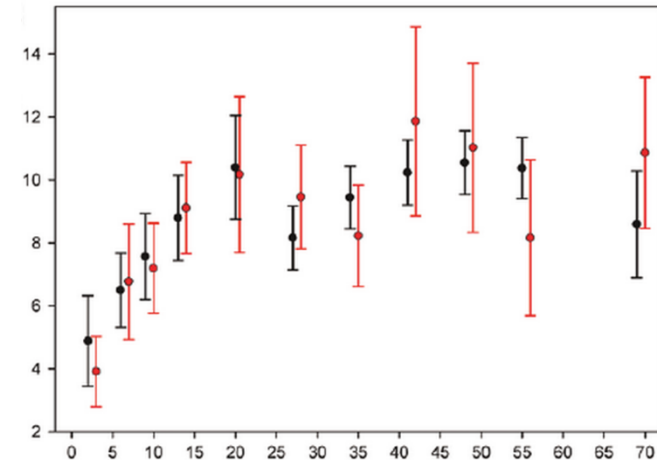

Summary

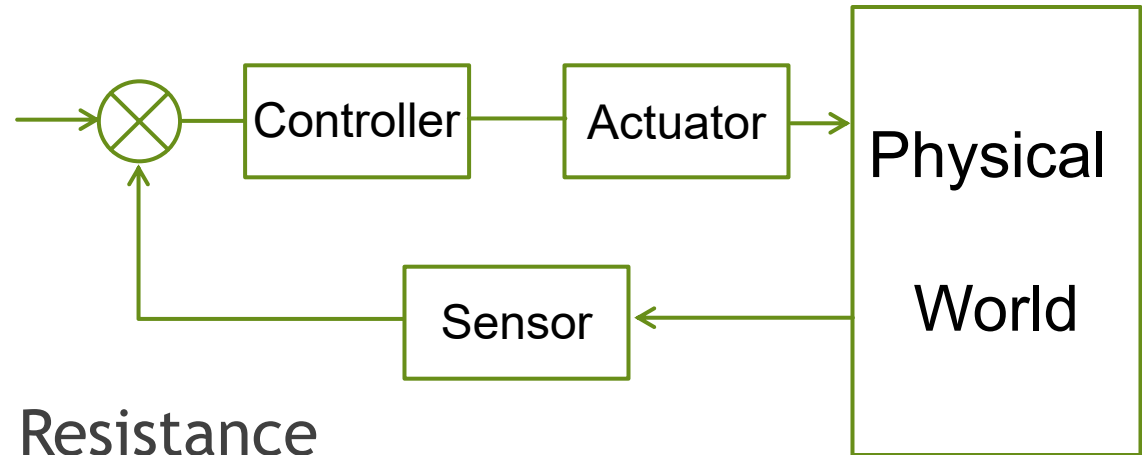

- ▶ Understanding of Resistance
- ▶ Computation of Resistance
- ▶ Measurement of Resistance

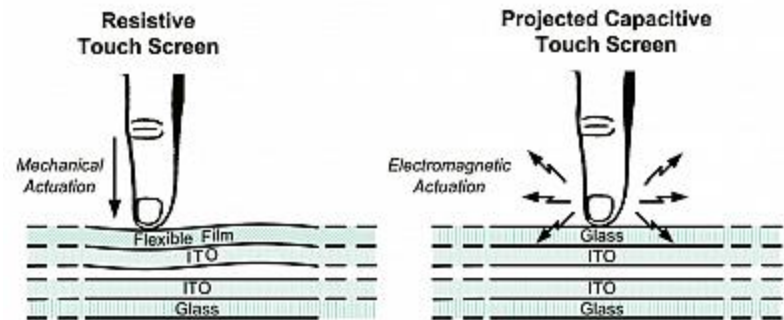

Resistor is a sensing element

Both **resistive** and **capacitive** technologies have a strong electrical component, both use ITO (Indium-Tin-Oxide, a clear conductor), and both will be around for a long time to come. A **resistive** touchscreen consists of a **flexible** top layer, then a layer of ITO (Indium-Tin-Oxide), an air gap and then another layer of ITO.

Outline of Module 2

- ▶ Lecture 1:
 - ▶ Measurement of Voltage
- ▶ Lecture 2:
 - ▶ Measurement of Current
- ▶ Lecture 3:
 - ▶ Measurement of Resistance
- ▶ Lecture 4:
 - ▶ Measurement of Capacitance
- ▶ Lecture 5:
 - ▶ Measurement of Inductance

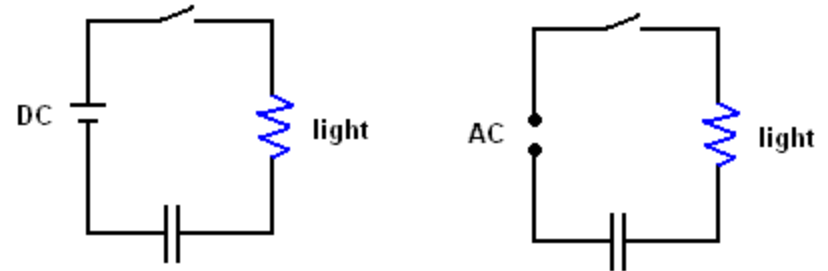
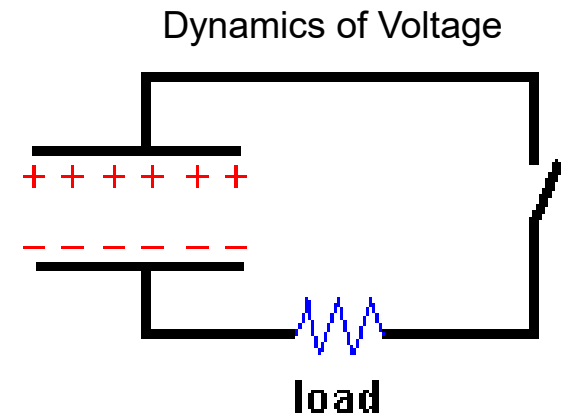
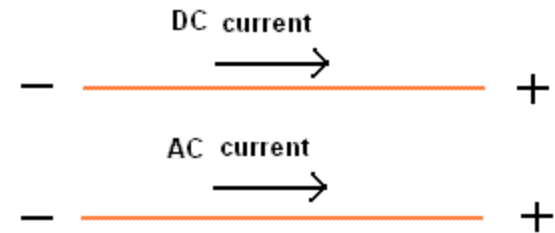



NANYANG
TECHNOLOGICAL
UNIVERSITY

School of Mechanical & Aerospace Engineering

Design, Machine, Control, Intelligence

Module 2 Lecture 4

MA4822

Measurement of Capacitance

Xie Ming, PhD (France)

mmxie@ntu.edu.sg

<http://personal.ntu.edu.sg/mmxie>

Outline

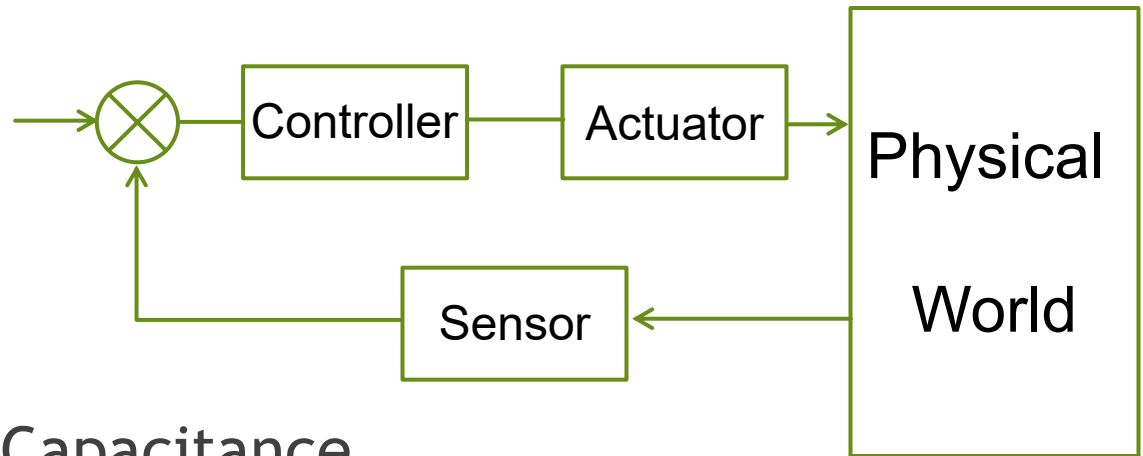

- ▶ Understanding of Capacitance
- ▶ Computation of Capacitance
- ▶ Measurement of Capacitance

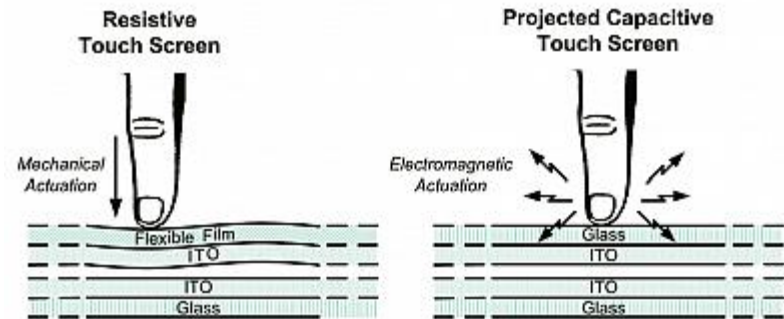

Both **resistive** and **capacitive** technologies have a strong electrical component, both use ITO (Indium-Tin-Oxide, a clear conductor), and both will be around for a long time to come. A **resistive** touchscreen consists of a **flexible** top layer, then a layer of ITO (Indium-Tin-Oxide), an air gap and then another layer of ITO.

Outline

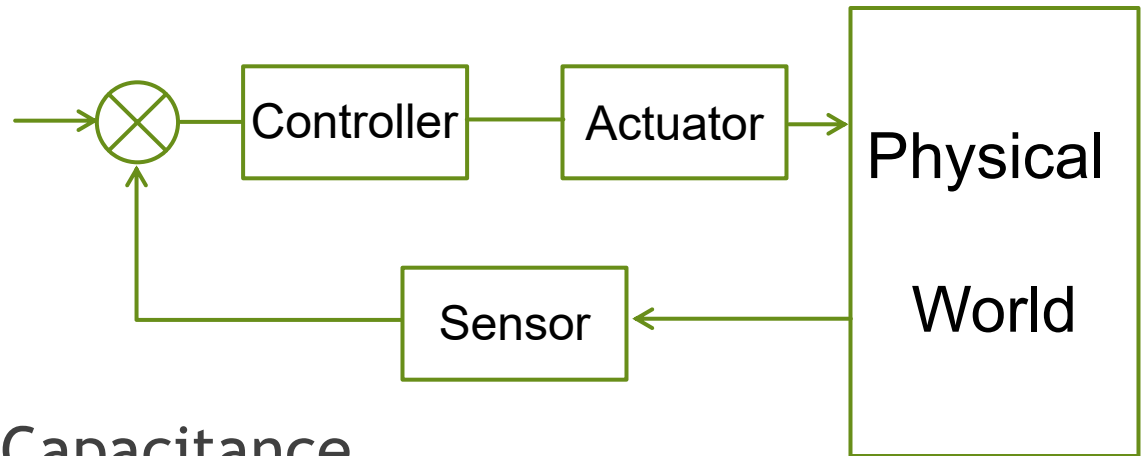

- ▶ Understanding of Capacitance
- ▶ Computation of Capacitance
- ▶ Measurement of Capacitance

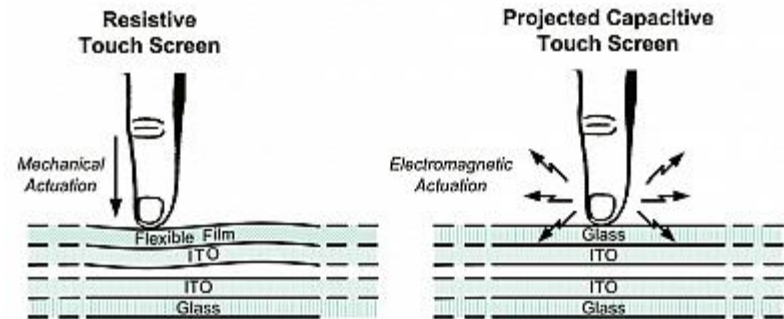

Both **resistive** and **capacitive** technologies have a strong electrical component, both use ITO (Indium-Tin-Oxide, a clear conductor), and both will be around for a long time to come. A **resistive** touchscreen consists of a **flexible** top layer, then a layer of ITO (Indium-Tin-Oxide), an air gap and then another layer of ITO.

Definition of Capacitor

- ▶ Capacitor refers to a device which can store variable electric charges or energy.

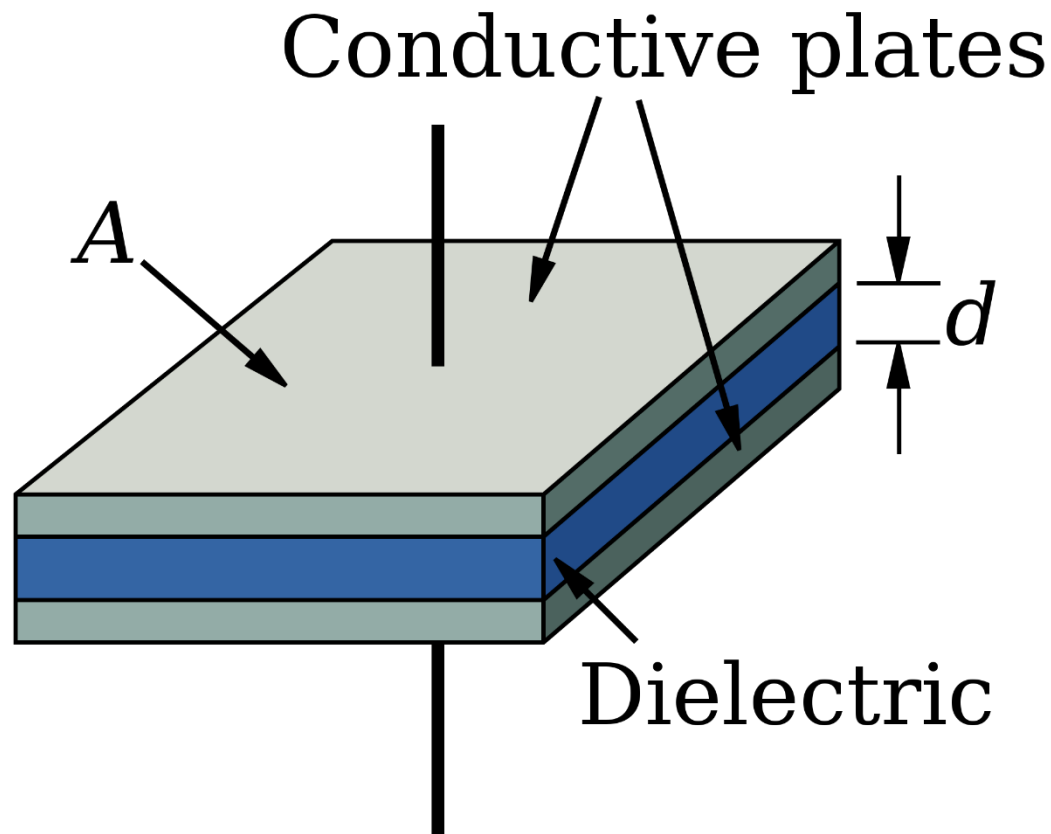

Similar Device: Elastic Spring

- ▶ It is a device which stores elastic potential energy.
- ▶ The energy stored inside a spring is not constant.

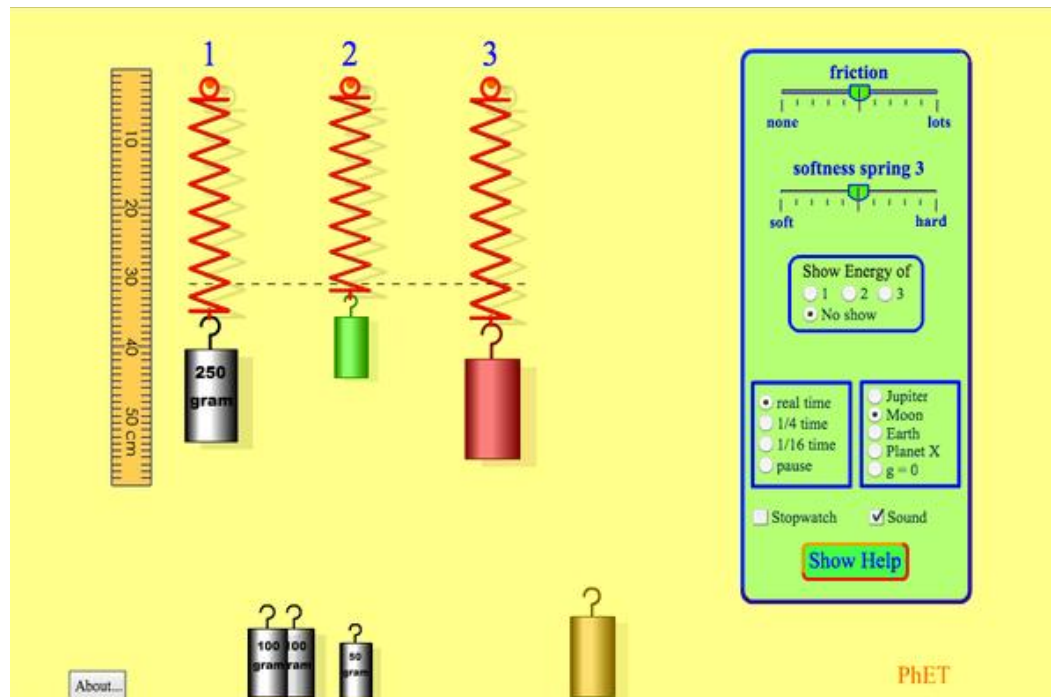

Properties of Dielectric Material

- ▶ A dielectric material (dielectric for short) is an electrical **insulator** that can be polarized by an applied electric field. When a dielectric is placed in an electric field, electric charges do not flow through the material.
- ▶ Dielectrics is the study of dielectric properties which concern the storage and dissipation of electric and magnetic energy in materials.

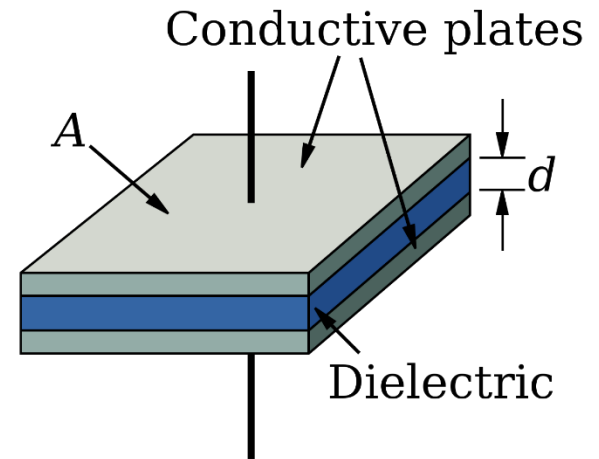

Property of Capacitor with Dielectric Material



$\frac{Q}{V}$ increases

Dielectrics

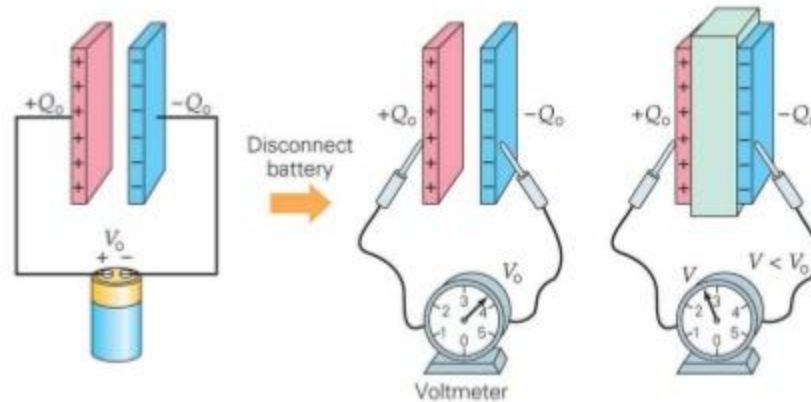

Decrease in voltages

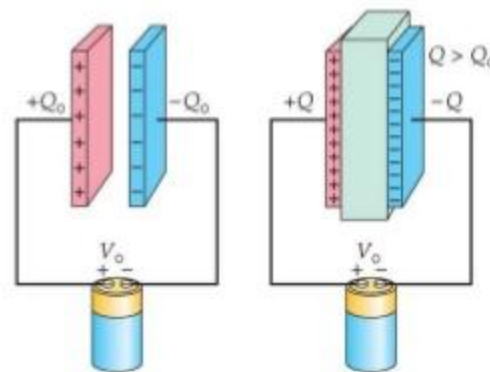

Increase in charges

Inserting a dielectric into a capacitor while either the voltage or the charge is held constant has the same effect – the ratio of charge to voltage increases.

Dielectric Constant ...

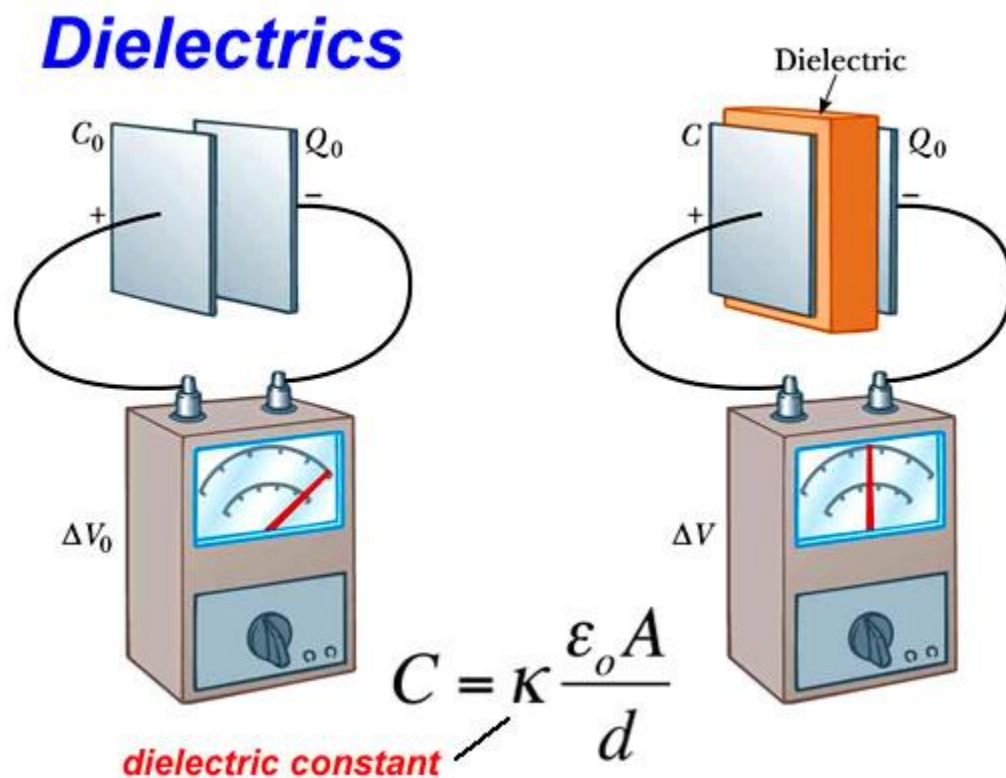

$$k = \frac{1}{4\pi\epsilon_0} = 9.0 \times 10^9 \text{ N.m}^2/\text{C}^2$$

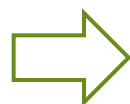

$$\epsilon_0 = 8.854 \times 10^{-12} \text{ C}^2/\text{N.m}^2$$

Graphic Representation of Capacitor

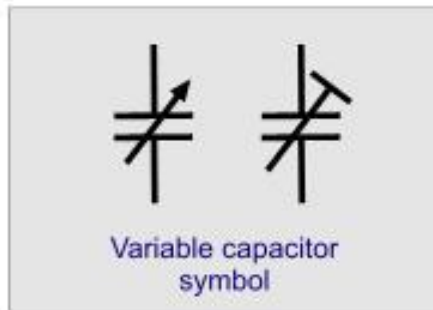
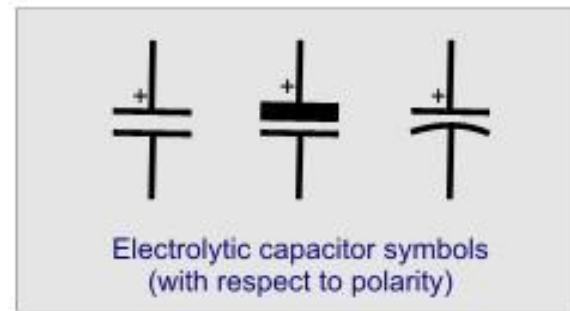
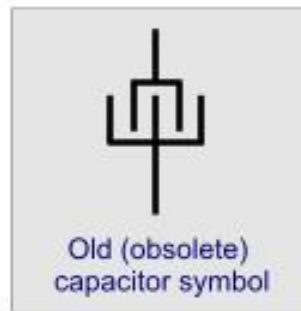
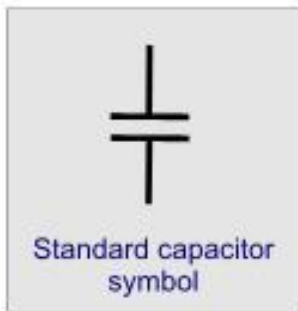

Parameters of Capacitor

- ▶ Electric charge: Q (Coulomb)
- ▶ Capacitance: C (Farad)
- ▶ Distance between two plates: d (meter)
- ▶ Area of parallel plates: A (meter²)

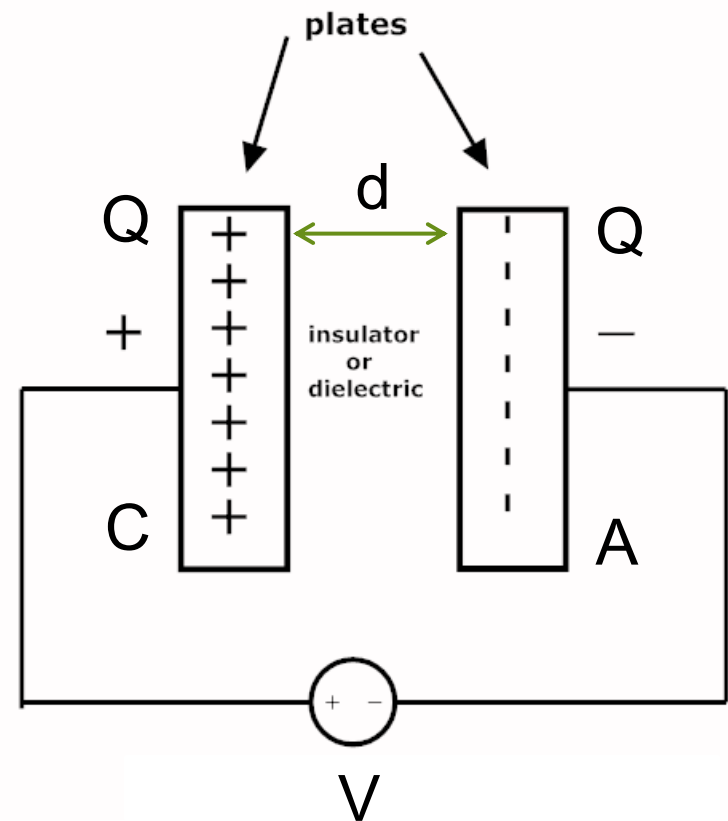

Capacitance without Dielectric

- When the space between the parallel plates is vacuum, we have:

$$C = \frac{Q}{V} \text{ (Coulomb/Volt)}$$

$$Q = \epsilon_0 \frac{V \times A}{d}$$

$$C = \epsilon_0 \frac{A}{d}$$

$$k = \frac{1}{4\pi\epsilon_0} = 9.0 \times 10^9 \text{ N.m}^2/\text{C}^2$$

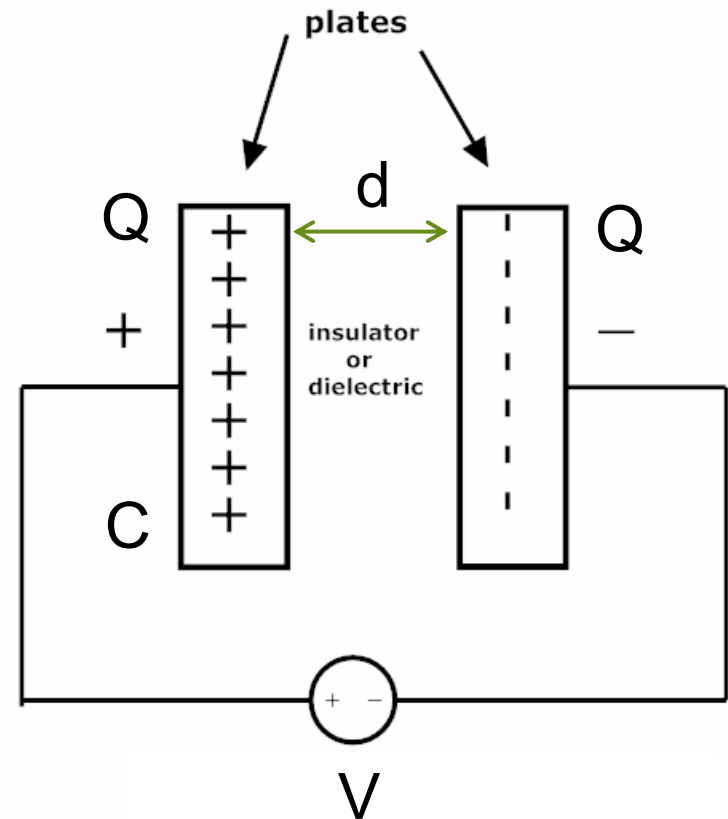

Example

- ▶ A parallel-plate capacitor has the area of 10.0 mm^2 . The distance between the plates is 0.1 mm . What is the capacitance?

- ▶ Answer:

$$C = \epsilon_0 \frac{A}{d}$$

$$C = 8.854 \times 10^{-12} \frac{10.0 \times 10^{-6}}{0.1 \times 10^{-3}} = 0.8854 \times 10^{-12} \text{ F}$$

$$k = \frac{1}{4\pi\epsilon_0} = 9.0 \times 10^9 \text{ N.m}^2/\text{C}^2$$

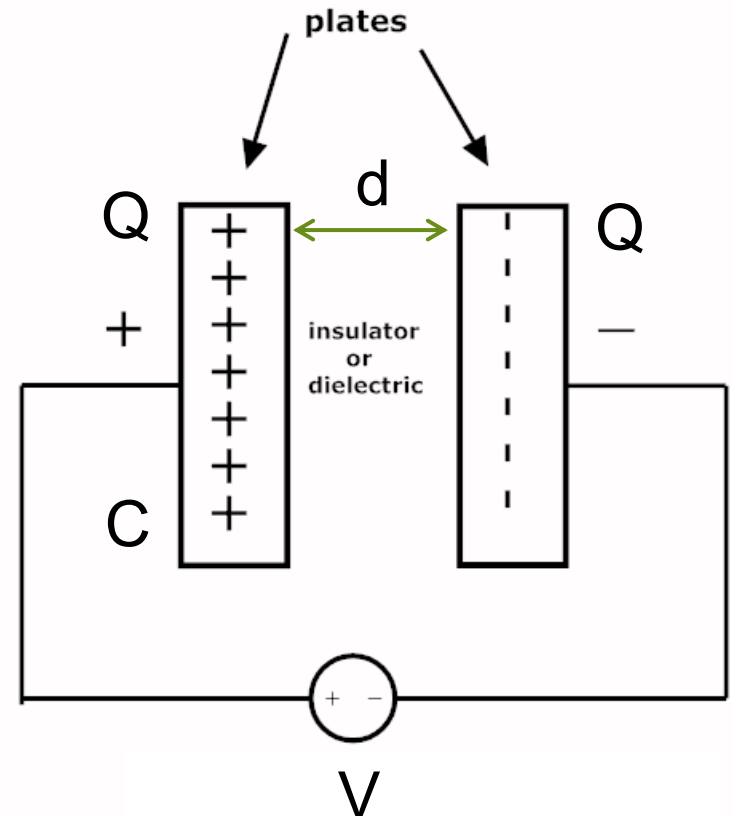

Capacitance with Dielectric

- ▶ When a dielectric is inserted into the parallel plates, the voltage will decrease by a factor of K , if the charge is kept constant.
- ▶ When the voltage is kept constant, the charge will increase by a factor of K . So, we have:

$$C = \frac{Q}{V} \text{ (Coulomb/Volt)}$$



$$Q = K\epsilon_0 \frac{V \times A}{d}$$

$$C = K\epsilon_0 \frac{A}{d}$$

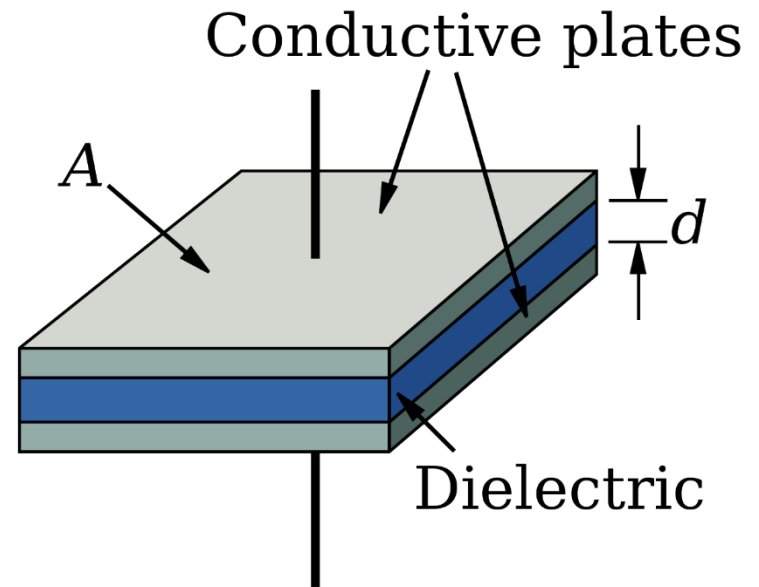

Outline

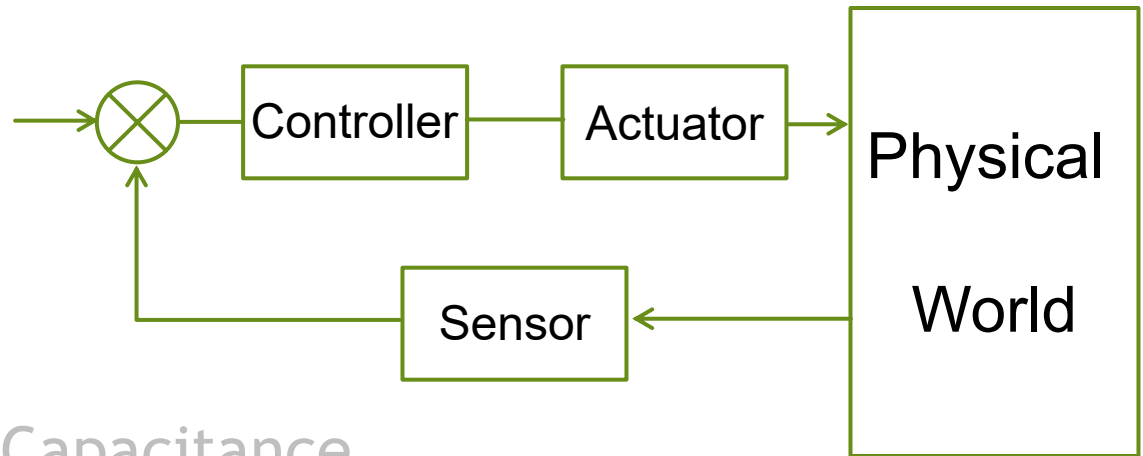

- ▶ Understanding of Capacitance
- ▶ Computation of Capacitance
- ▶ Measurement of Capacitance

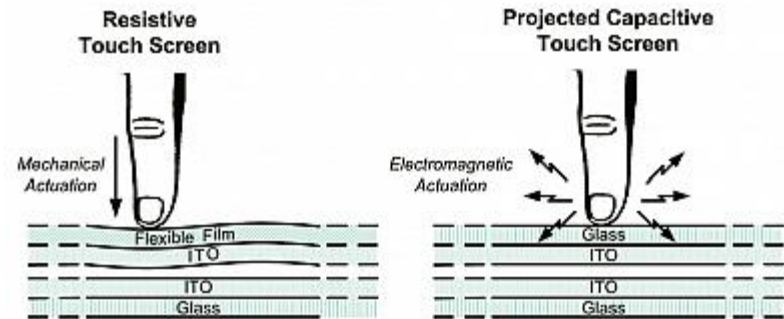

Both **resistive** and **capacitive** technologies have a strong electrical component, both use ITO (Indium-Tin-Oxide, a clear conductor), and both will be around for a long time to come. A **resistive** touchscreen consists of a **flexible** top layer, then a layer of ITO (Indium-Tin-Oxide), an air gap and then another layer of ITO.

Unit of Measurement of Capacitance

- ▶ The SI unit of capacitance is the **farad** (symbol: F), named after the English physicist Michael Faraday.
- ▶ A 1 **farad** capacitor, when charged with 1 coulomb of electrical charge, has a potential difference of 1 volt between its plates.

$$C = \frac{Q}{V} \text{ (Coulomb/Volt)}$$

$$C = \frac{Q}{V} \text{ (Farad)}$$

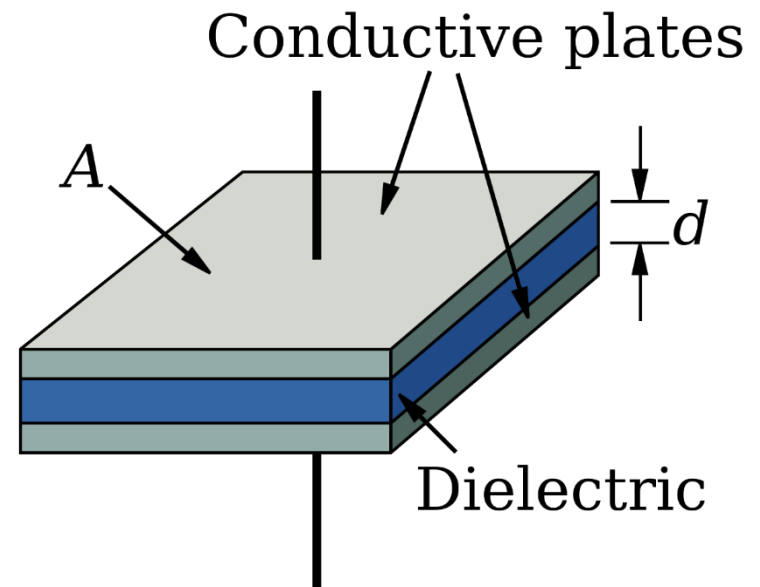

Capacitors Could Be Connected in Series

Calculation:



$$\frac{1}{C_{Tot}} = \frac{1}{C_1} + \frac{1}{C_2} + \dots + \frac{1}{C_{N-1}} + \frac{1}{C_N}$$

Example:

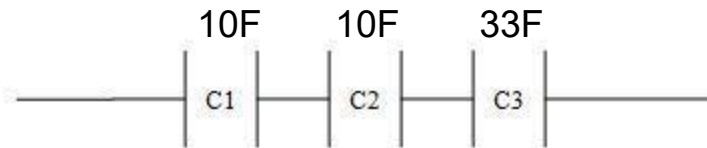

$$\frac{1}{C_{total}} = \frac{1}{10F} + \frac{1}{10F} + \frac{1}{33F} = 0.1F + 0.1F + 0.03F = 0.23F$$

$$C_{total} = \frac{1}{0.23F} = 4.35F$$

Capacitors Could Be Connected in Parallel

Calculation:

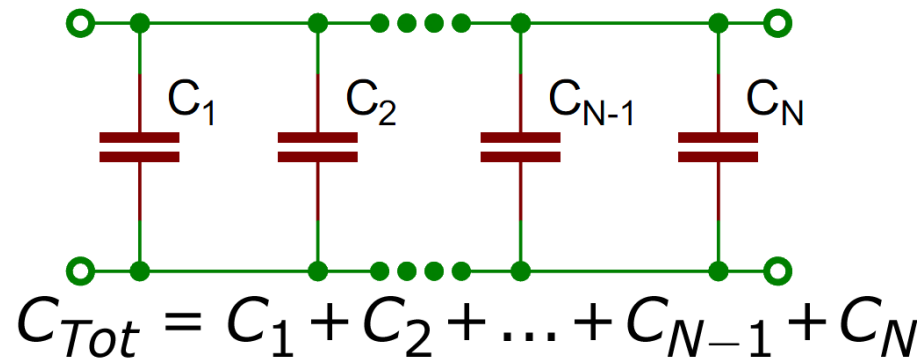

Example:

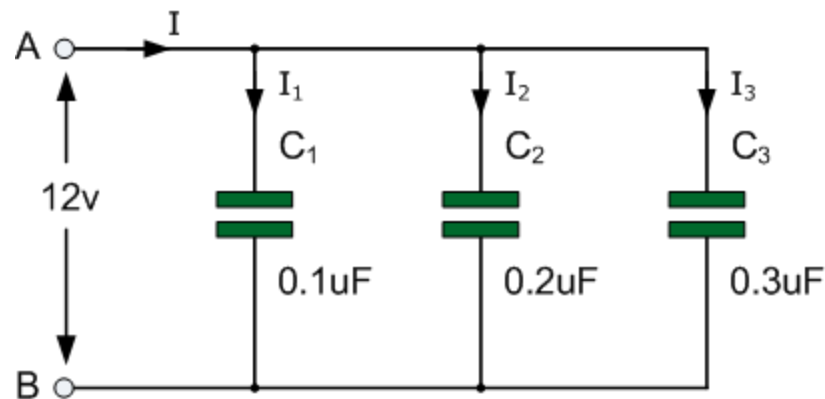

Dynamics of Capacitor

- Transient response
- Steady-state response

► Transient Response:

$$Q = \epsilon_0 \frac{V \times A}{d}$$

$$i = C \frac{dv}{dt}$$

Time Domain

Frequency Domain

$$\frac{I(s)}{V(s)} = C \times s$$

$$s = \sigma + j\omega$$

This is a vector

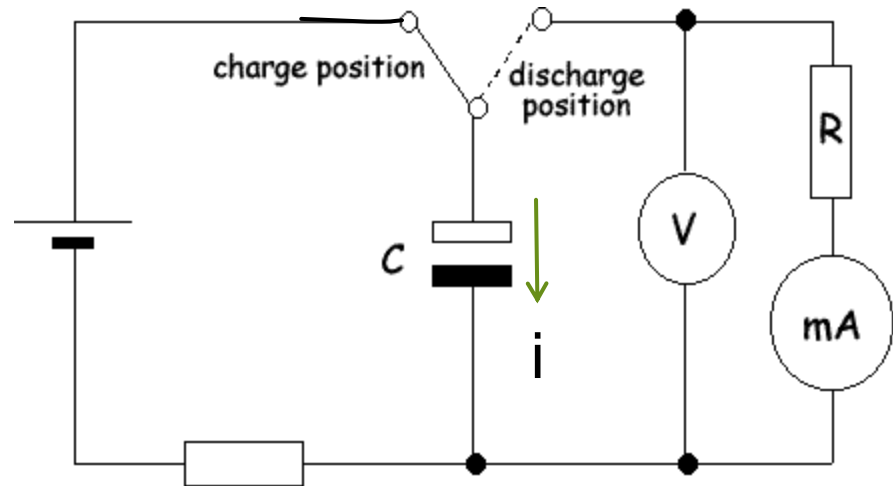

Frequency Response of Capacitor ...

► AC Circuit:

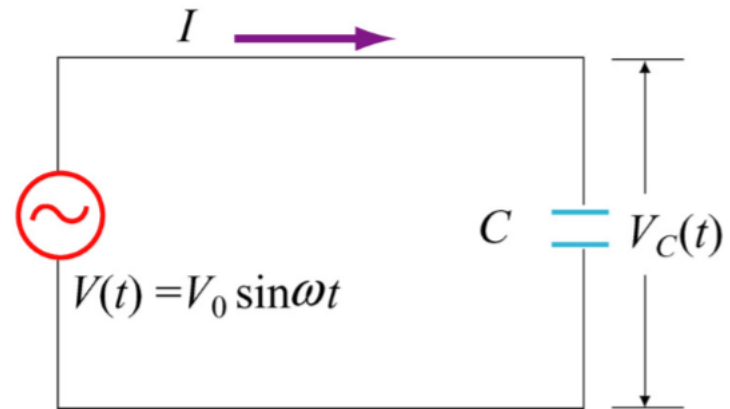
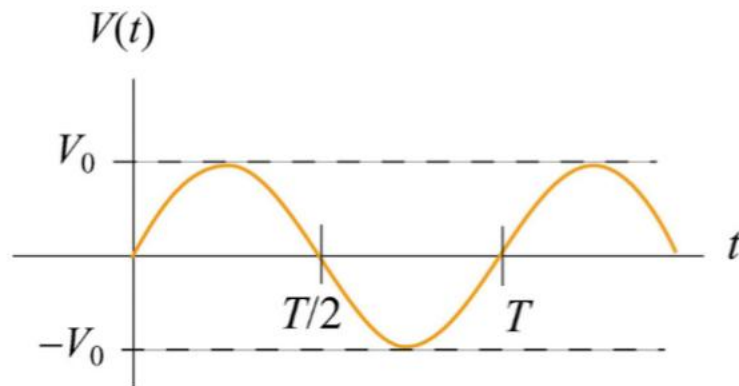

$$\omega = 2\pi f \quad \omega = \frac{2\pi}{T}$$

- Frequency response

Frequency Domain

$$\frac{I(s)}{V(s)} = C \times s \quad \xrightarrow{s = 0 + j\omega} \quad \frac{I(j\omega)}{V(j\omega)} = \frac{1}{1/j\omega C} \quad \longleftarrow \text{Impedance}$$

Example of Frequency Response:

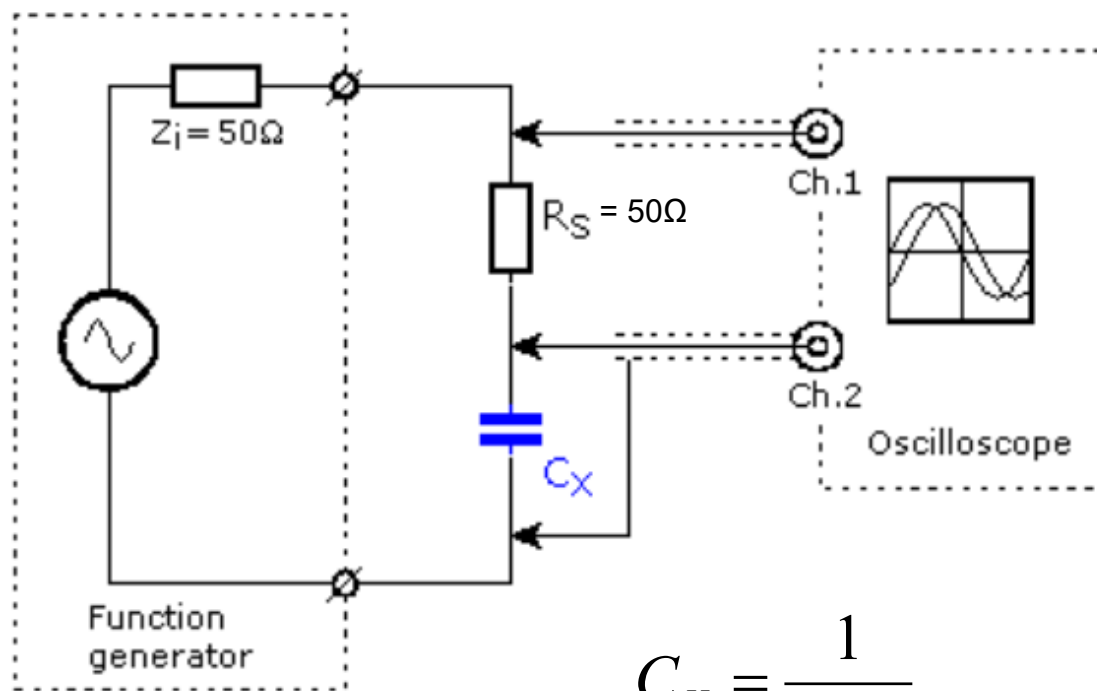

$$C_X = \frac{1}{\omega Z_X}$$

$$\omega = 2\pi f$$

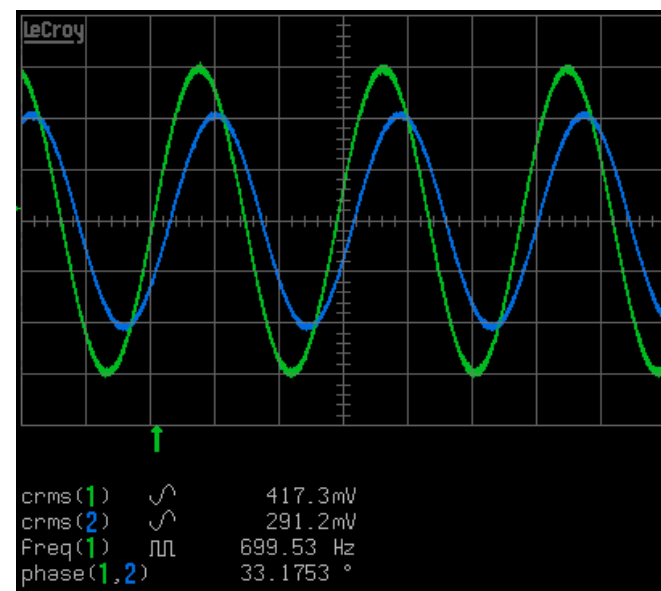
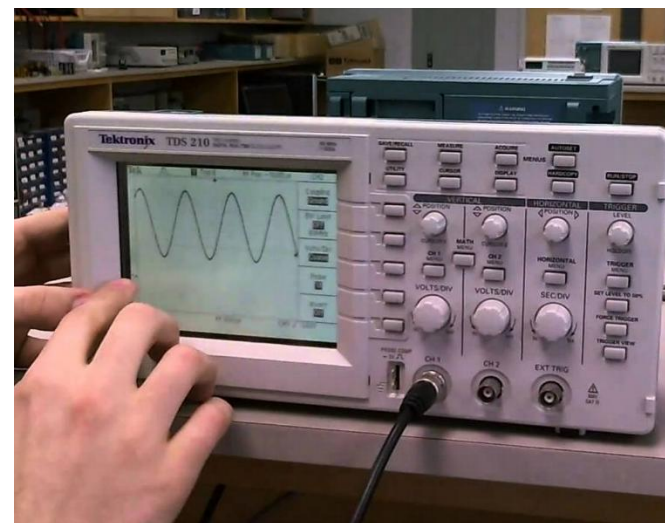

Frequency Response of Capacitor ...

- Kirchhoff's Voltage Rule:

$$V(t) - V_C(t) = 0$$

$$V(t) - \frac{Q(t)}{C} = 0$$

$$Q(t) = C \times V(t) = CV_0 \sin(\omega t)$$

$$I(t) = \frac{dQ(t)}{dt}$$

$$I(t) = \omega CV_0 \cos(\omega t)$$

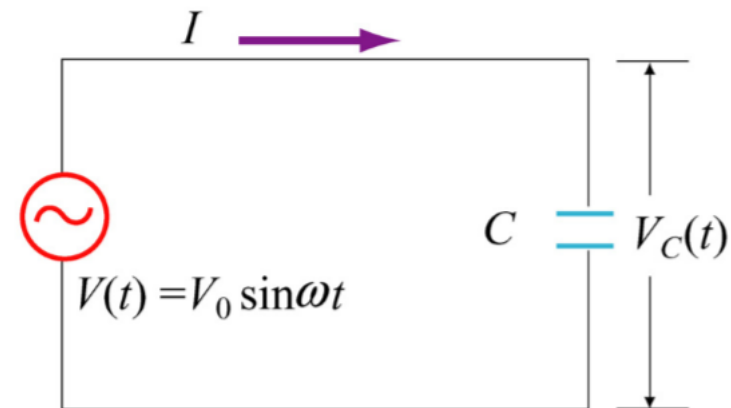
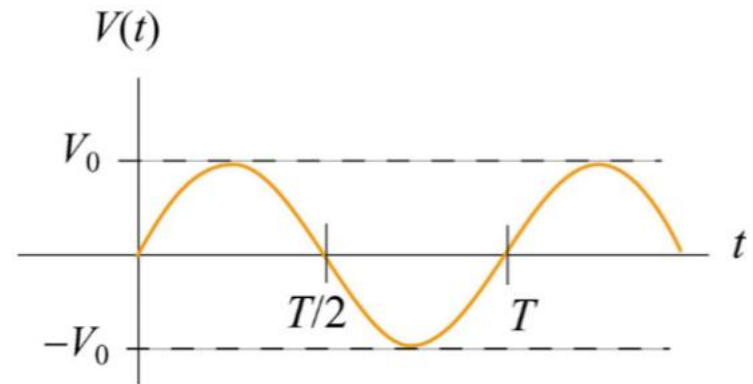

$$C = \frac{Q}{V} \text{ (Coulomb/Volt)}$$

Frequency Response of Capacitor ...

► Capacitor's Resistance:

$$I(t) = \omega C V_0 \cos(\omega t)$$

$$I(t) = \frac{V_0}{(1/\omega C)} \cos(\omega t) = I_0 \cos(\omega t)$$

$$I_0 = \frac{V_0}{(1/\omega C)} = \frac{V_0}{Z_C}$$

$$Z_C = \frac{1}{\omega C}$$



It is called Capacitive Resistance

Impedance = {Resistance, Reactance}

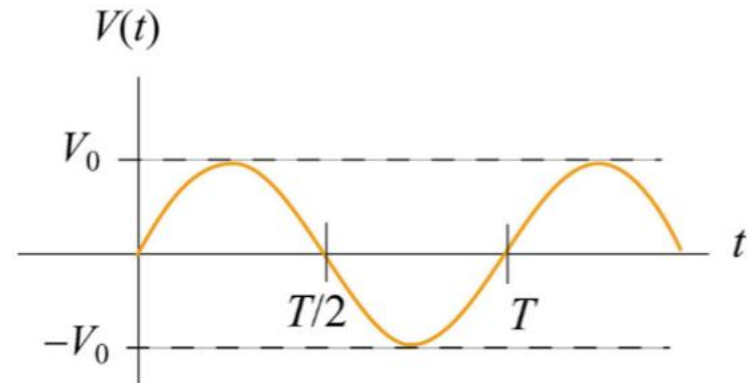

• Frequency response

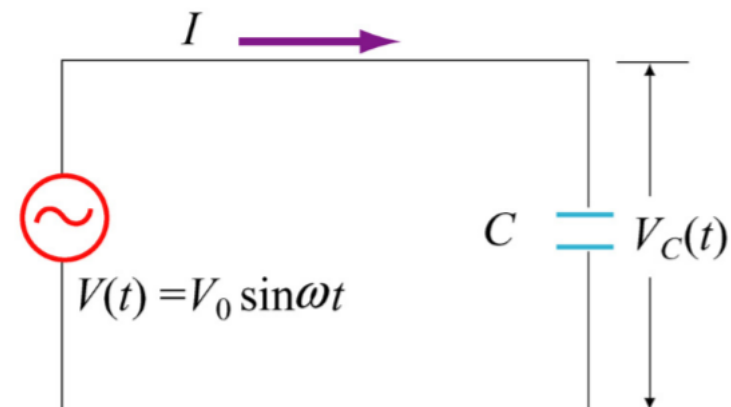

Frequency Response ...

► Phasor Diagram:

$$I(t) = \omega C V_0 \cos(\omega t)$$

$$\frac{I_0}{V_0} = \frac{1}{\left(\frac{1}{\omega C}\right)} = \frac{1}{Z}$$

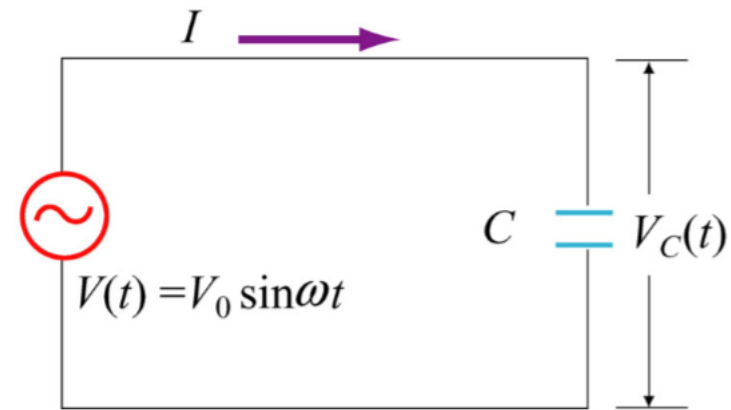

Impedance = {Resistance, Reactance}

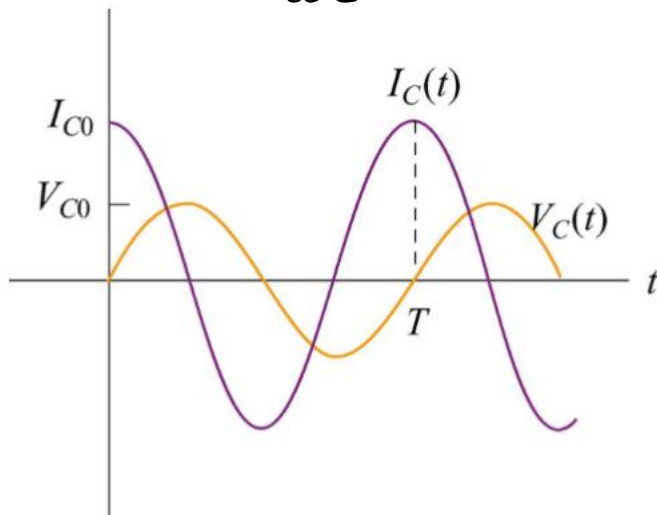

$$I_{C0} = I_0 \quad V_{C0} = V_0$$

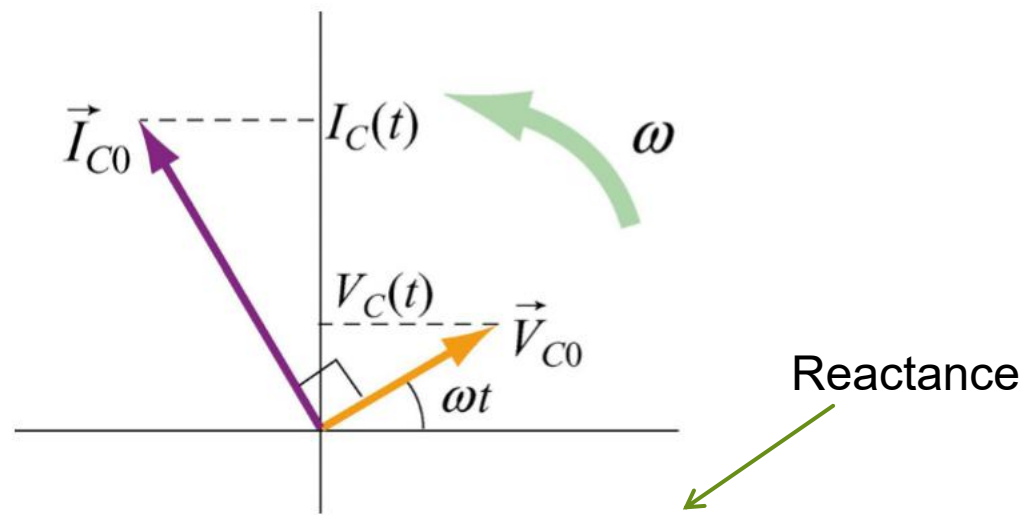

Current leads voltage by 90 degrees

Computing Methods Using AC Circuits

- ▶ Z_X refers to the resistance of the electrical parameter of a capacitor under measurement. R_{ref} is a resistor with a precise value of resistance.
- ▶ Hence, the value of capacitance could be calculated by:

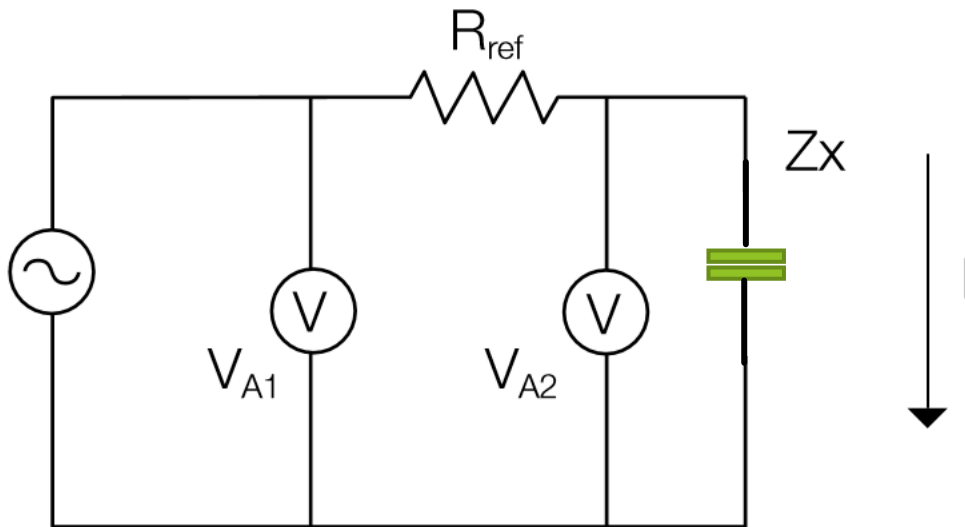

$$Z_X = \frac{V_{A2}}{I} = \frac{V_{A2}}{V_{A1} - V_{A2}} R_{ref}$$

$$C_X = \frac{1}{\omega Z_X}$$

$$\omega = 2\pi f$$

Example

- ▶ Voltage amplitude measured at A1 is: $V_{A1} = 1.929$ V. Voltage amplitude measured at A2 is $V_{A2} = 0.310$ V. Phase difference between voltage measured at A2 relative to A1 is $\theta = -79.95^\circ$. What is the amplitude of the difference between Voltage at A1 and Voltage at A2?

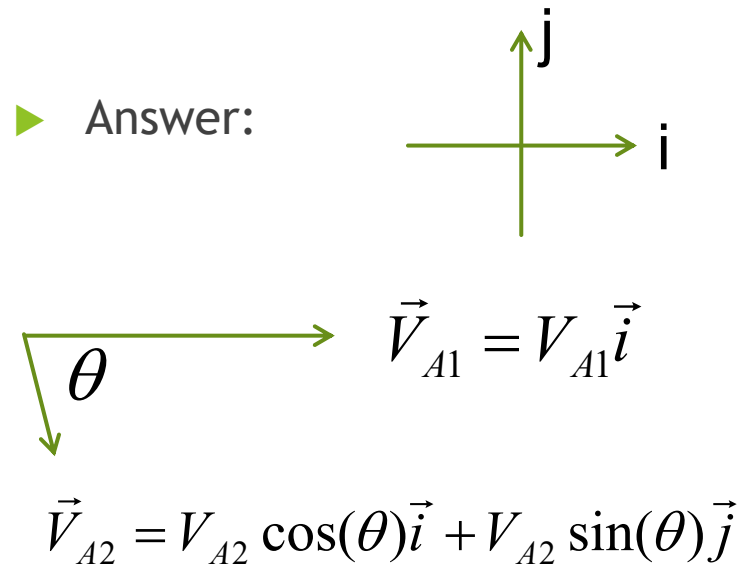

(to continue)

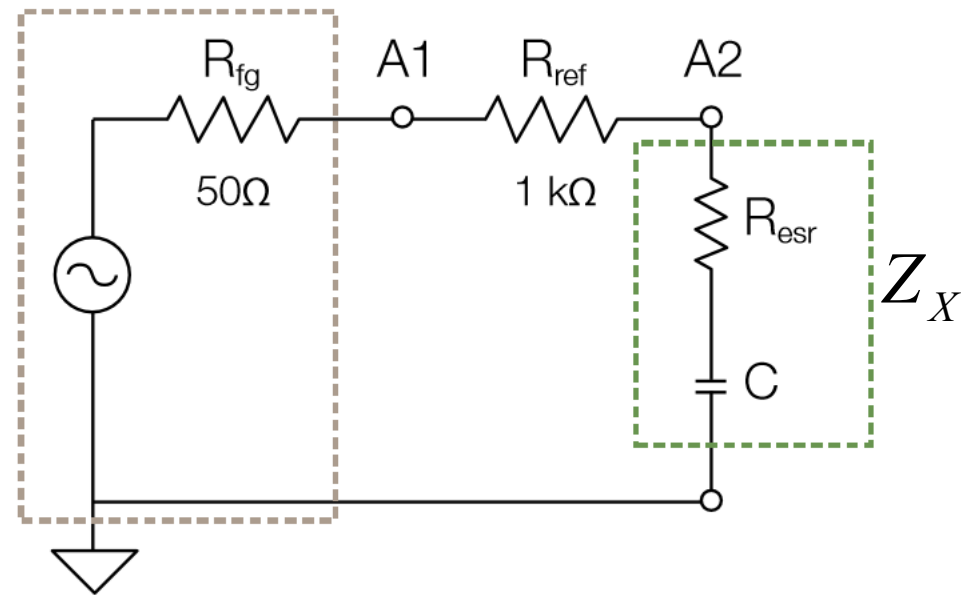

Answer:

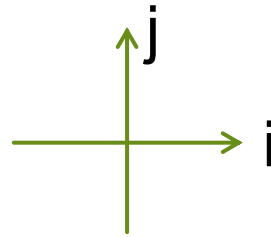

$$\vec{V}_{A1} = V_{A1} \vec{i}$$

$$\vec{V}_{A2} = V_{A2} \cos(\theta) \vec{i} + V_{A2} \sin(\theta) \vec{j}$$

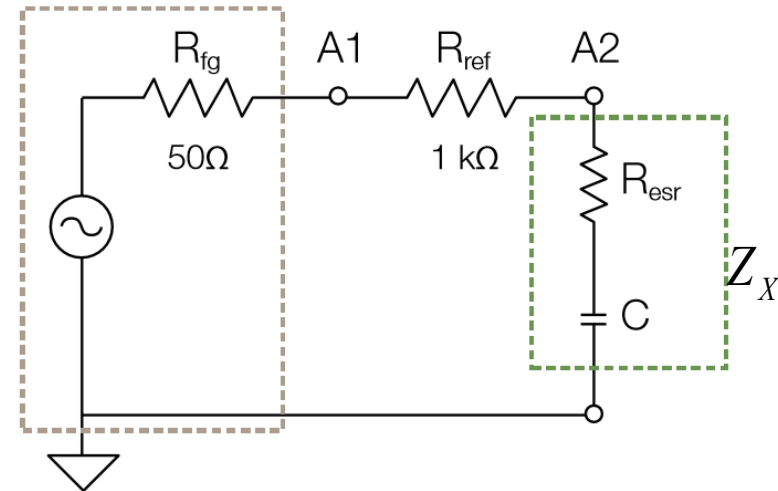

$$|\vec{V}_{A1} - \vec{V}_{A2}| = \sqrt{(V_{A1} - V_{A2} \cos(\theta))^2 + (0 - V_{A2} \sin(\theta))^2}$$

$$|\vec{V}_{A1} - \vec{V}_{A2}| = \sqrt{V_{A1}^2 - 2V_{A1}V_{A2} \cos(\theta) + V_{A2}^2}$$

$$|\vec{V}_{A1} - \vec{V}_{A2}| = \sqrt{1.929^2 - 2 \cdot 1.929 \cdot 0.31 \cos(-79.95^\circ) + 0.31^2}$$

Example

- ▶ Voltage amplitude measured at A1 is: $V_{A1} = 1.929$ V. Voltage amplitude measured at A2 is $V_{A2} = 0.310$ V. Phase difference between voltage measured at A2 relative to A1 is $\theta = -79.95^\circ$. What is the capacitance if $R_{ref} = 1$ K Ohms?

- ▶ Answer:

$$Z_X = \frac{V_{A2}}{I} = \frac{V_{A2}}{V_{A1} - V_{A2}} R_{ref}$$

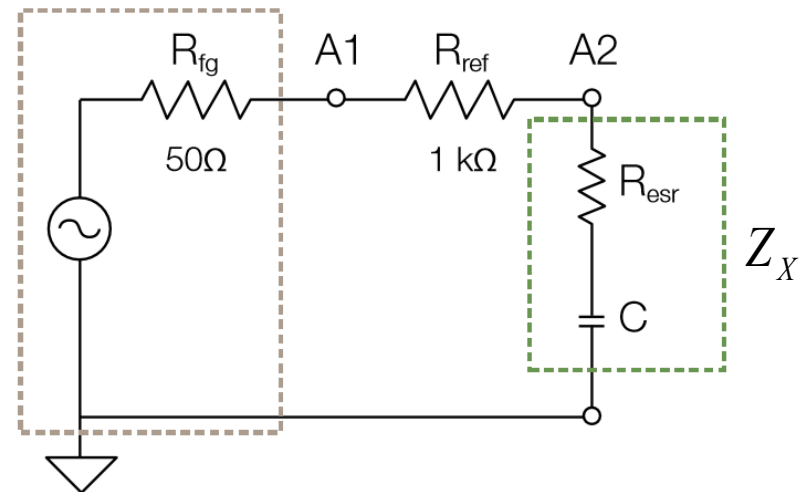

(to continue)

Answer

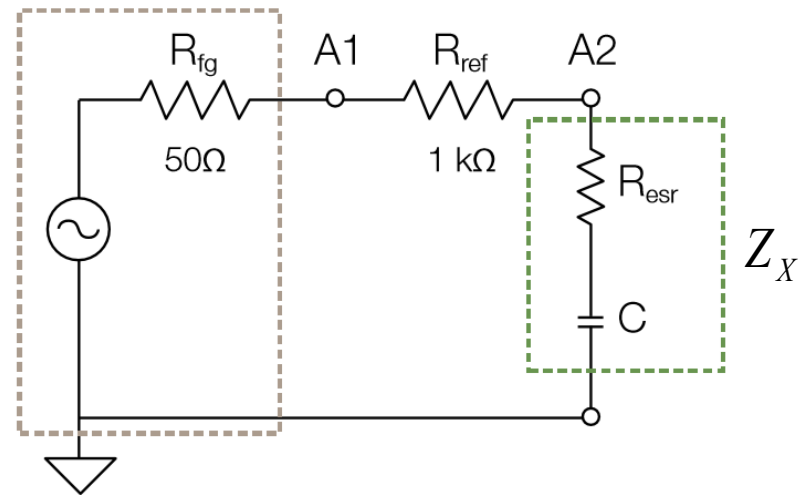

$$Z_X = \frac{V_{A2}}{I} = \frac{V_{A2}}{V_{A1} - V_{A2}} R_{ref}$$

$$Z_X = \frac{0.31 \cdot 1000}{\sqrt{1.929^2 - 2 \cdot 1.929 \cdot 0.31 \cos(-79.95^\circ) + 0.31^2}}$$

$$Z_X = 163.193 \Omega \quad \Rightarrow \quad C_X = \frac{1}{\omega Z_X}$$

Computing Methods Using RC Circuits

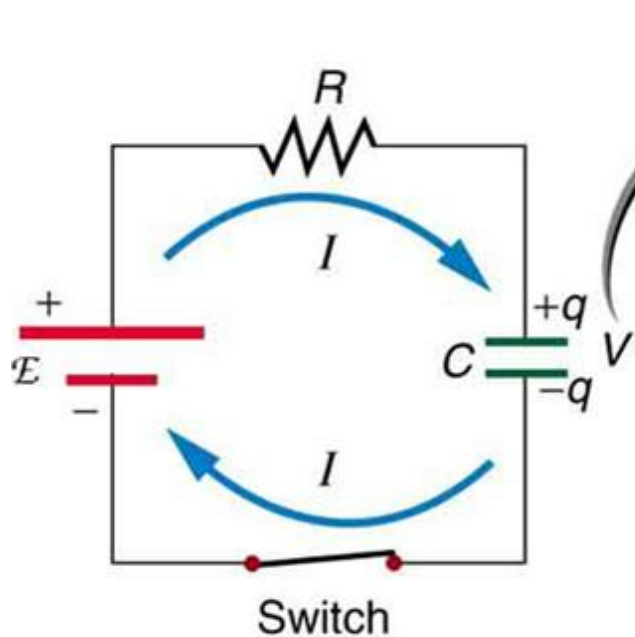

(a)

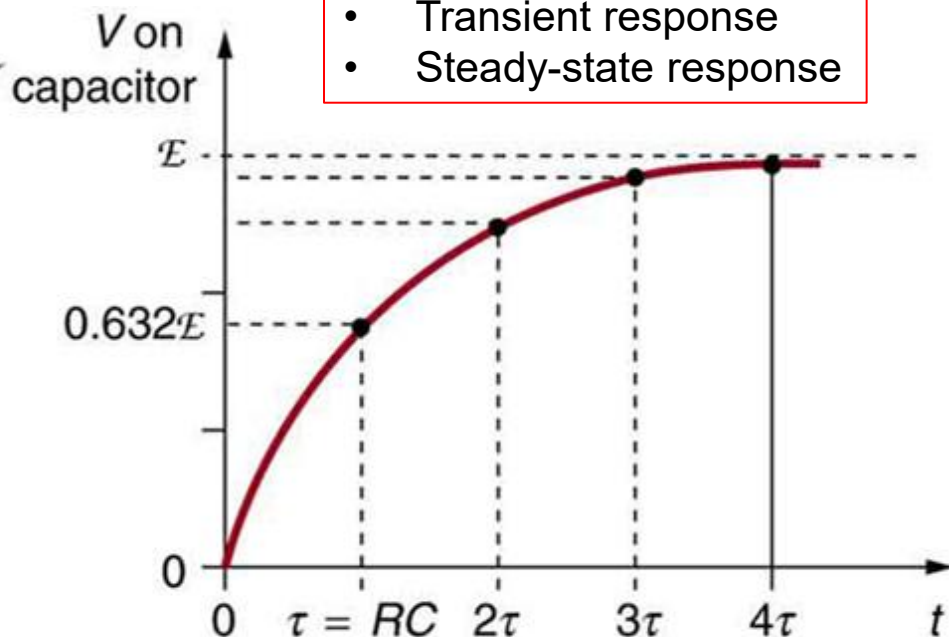

- Transient response
- Steady-state response

(b)

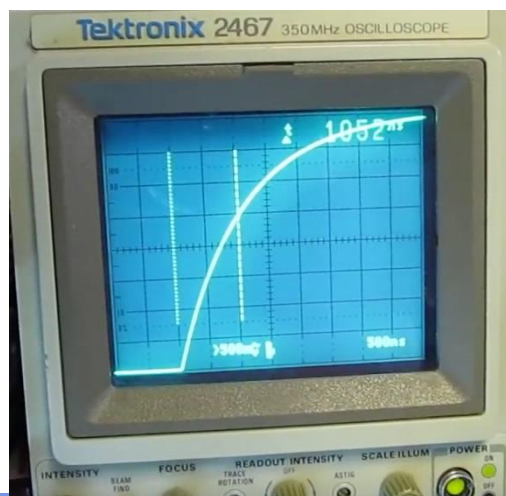

https://www.youtube.com/watch?v=74fz9iwZ_sM

Example

- ▶ In the following RC circuit, express the current as a function of time when the switch s is turned on. If the current is $i(1)$ when $t=1\text{s}$, what is the equation for the calculation of capacitance?
- ▶ Answer:

$$\varepsilon = \frac{q}{C} + iR$$

$$i = \frac{\varepsilon}{R} - \frac{q}{RC}$$

$$\frac{dq}{dt} = \frac{\varepsilon}{R} - \frac{q}{RC}$$

$$q = C\varepsilon(1 - e^{-t/RC})$$

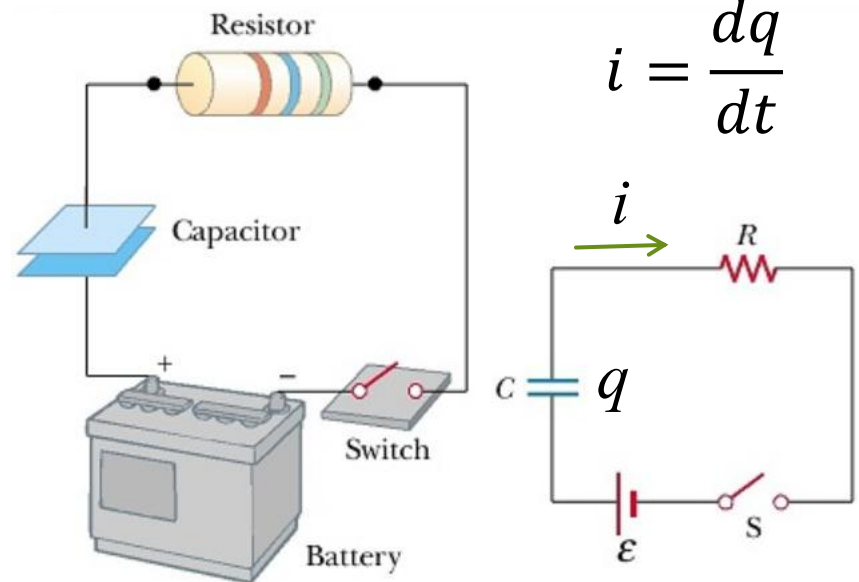

$$i = \frac{dq}{dt}$$

$$i = \frac{dq}{dt} = C \frac{dv}{dt}$$

$$q(t) = C\varepsilon(1 - e^{-t/RC})$$

$$i(t) = \frac{dq}{dt} = \frac{\varepsilon}{R} e^{-t/RC}$$

$$\frac{-t}{RC} = \ln\left(\frac{i(t)R}{\varepsilon}\right)$$

$$C = \frac{-t}{R \times \ln\left(\frac{i(t)R}{\varepsilon}\right)}$$

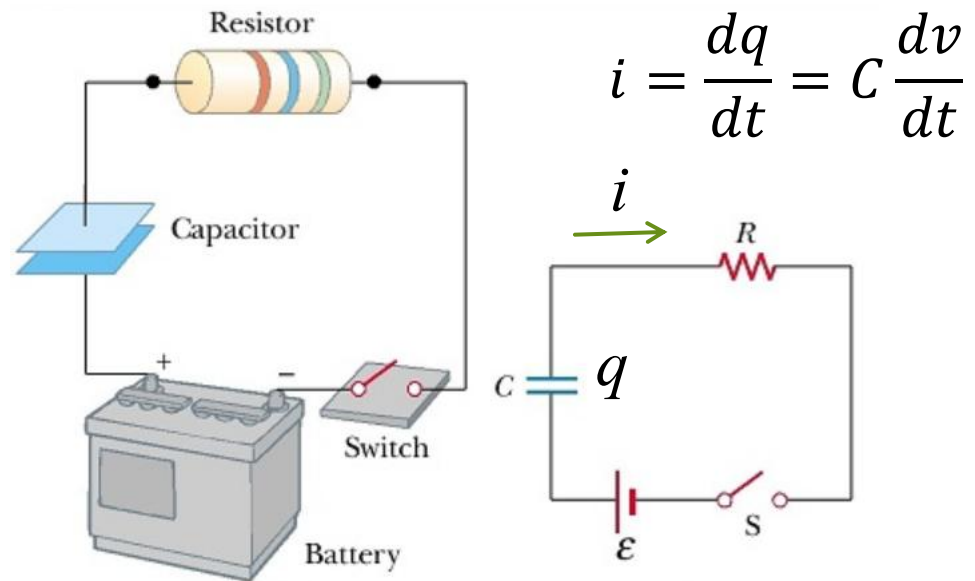

$$C = \frac{-t}{R \times \ln\left(\frac{i(t)R}{\epsilon}\right)}$$

b) When $t = 1\text{s}$, we have:

$$C = \frac{-1}{R \times \ln\left(\frac{i(1)R}{\epsilon}\right)}$$

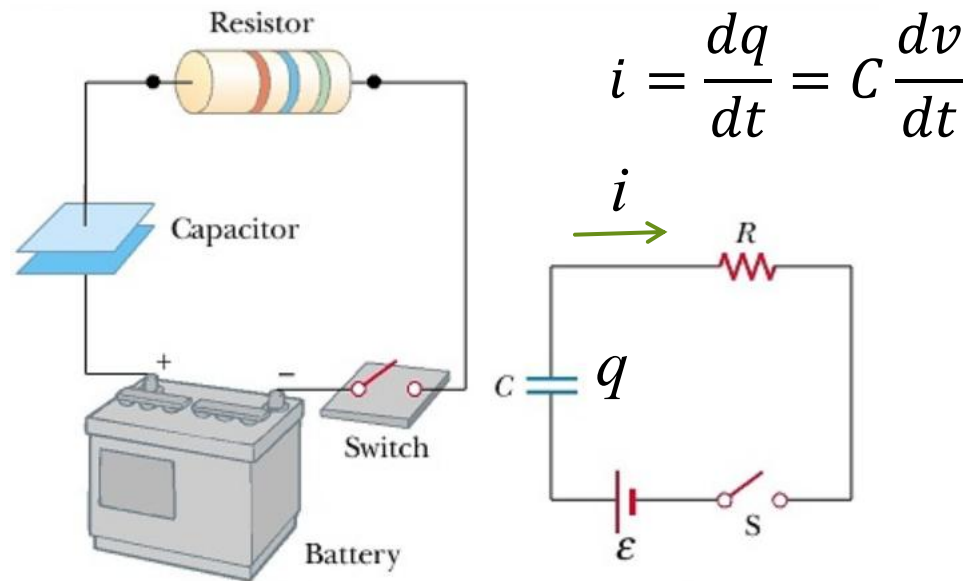

Note: $i(1)$ is given by the question

Example

- ▶ In a RC circuit, the resistor's resistance is 50 Kilo Ohms. If we have the plot of voltage across capacitor as shown in the figure, what is the capacitance and the applied voltage?

- ▶ Answer:

$$q = C\varepsilon(1 - e^{-t/RC})$$

$$i = \frac{dq}{dt} = \frac{\varepsilon}{R} e^{-t/RC}$$

$$e^{t/RC} = \frac{\varepsilon}{iR}$$

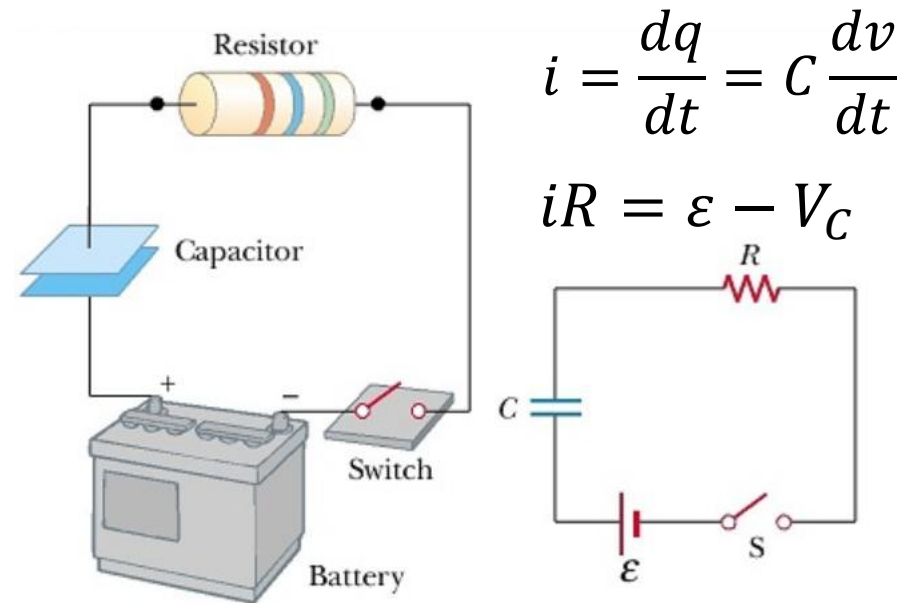
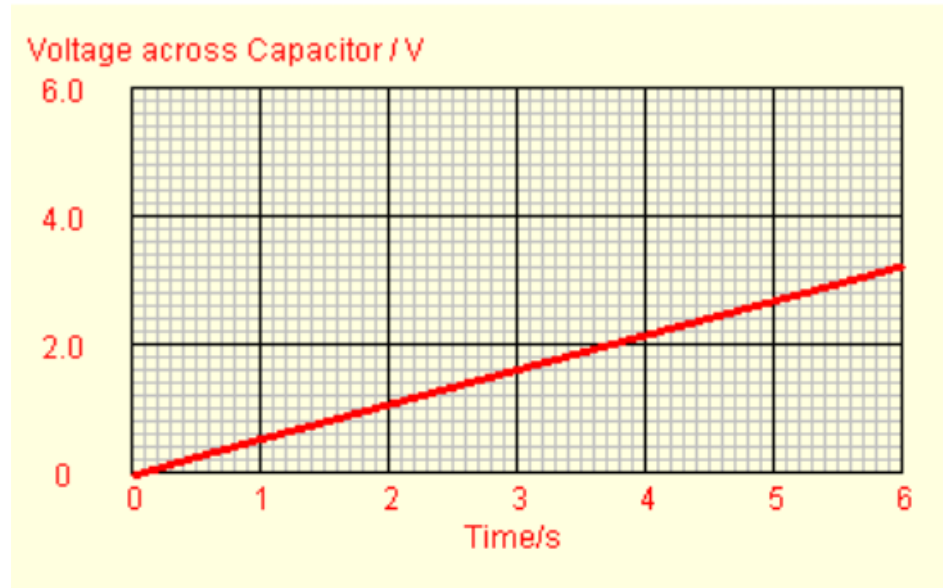

$$i = \frac{dq}{dt} = C \frac{dv}{dt}$$

$$iR = \varepsilon - V_C$$

Continued

$$e^{t/RC} = \frac{\varepsilon}{iR}$$

$$iR = \varepsilon - V_C$$

$$e^{t/RC} = \frac{\varepsilon}{\varepsilon - V_C}$$

Voltage across Capacitor / V

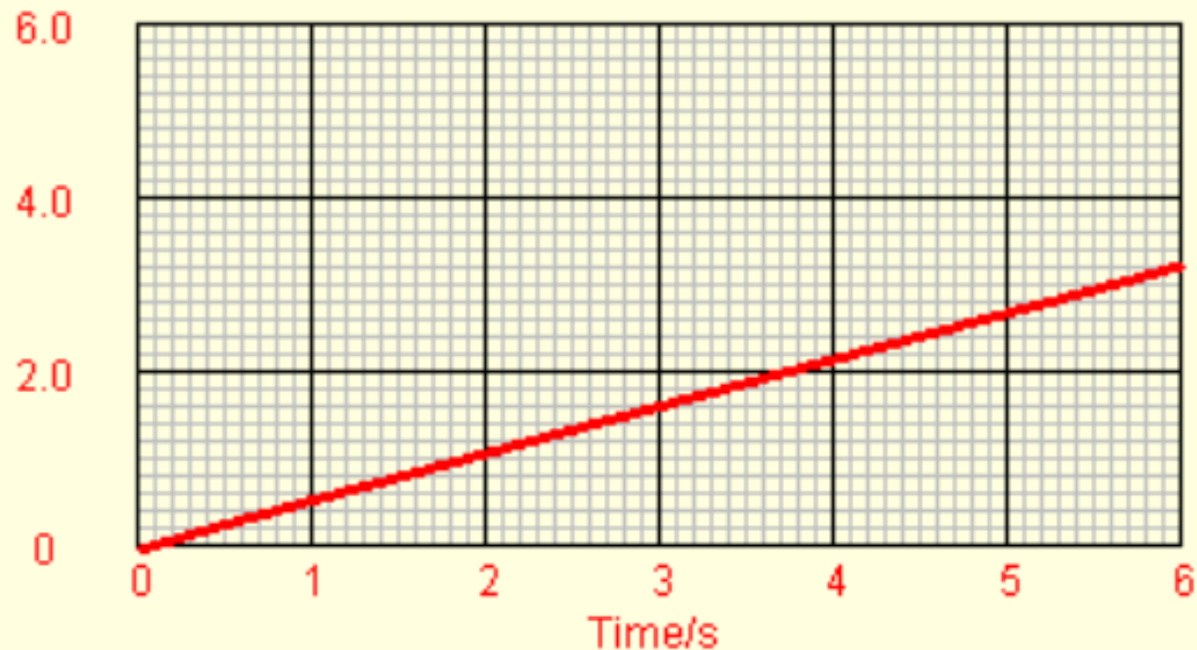

$$t = 1$$

$$e^{1/RC} = \frac{\varepsilon}{\varepsilon - 0.55}$$

$$t = 2$$

$$e^{2/RC} = \frac{\varepsilon}{\varepsilon - 1.00}$$

Hints

$$e^{1/RC} = \frac{\varepsilon}{\varepsilon - 0.55}$$

$$e^{2/RC} = \frac{\varepsilon}{\varepsilon - 1.00}$$

$$\frac{\varepsilon}{\varepsilon - 0.55} \times \frac{\varepsilon}{\varepsilon - 0.55} = \frac{\varepsilon}{\varepsilon - 1.00}$$

$$\varepsilon^2 - 1.0\varepsilon = \varepsilon^2 - 1.1\varepsilon + 0.3025$$

$$\varepsilon = 3.025 \text{ volts}$$

$$e^{t/RC} = \frac{\varepsilon}{\varepsilon - V_C}$$



$$C = \frac{1}{R \times \ln\left(\frac{\varepsilon}{\varepsilon - 0.55}\right)}$$



Computing Methods Using Bridge-Circuits

- Four devices form a rectangle loop. A known power source is applied to one pair of diagonal points. The voltage output from another pair of diagonal points indicates the in-balance or out-of-balance of the bridge circuit.

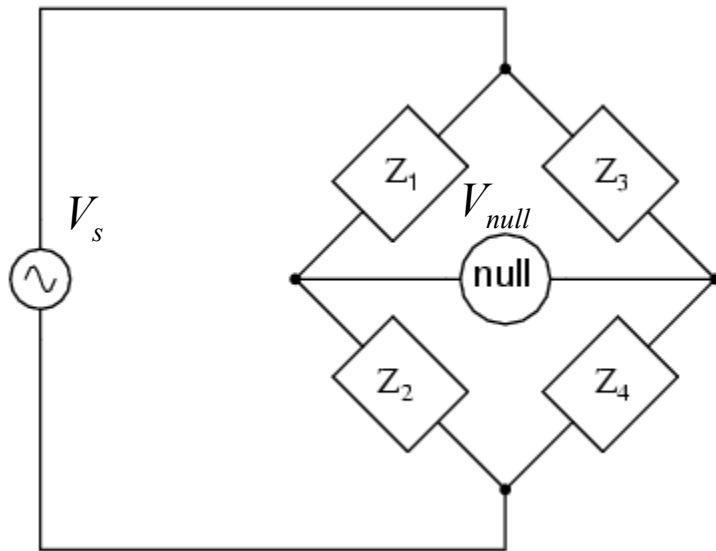

$$V_{null} = \frac{V_s}{Z_1 + Z_2} Z_2 - \frac{V_s}{Z_3 + Z_4} Z_4$$

$$0 = \frac{V_s}{Z_1 + Z_2} Z_2 - \frac{V_s}{Z_3 + Z_4} Z_4$$

$$\frac{Z_2}{Z_1 + Z_2} = \frac{Z_4}{Z_3 + Z_4}$$

Example

- ▶ The capacitance C_x to be calculated is connected to a bridge-circuit's arm. Alternating current from the built-in generator G is fed to one of the diagonals of the bridge. A balance indicator I is connected to the other diagonal of the bridge through an amplifier U . The bridge is balanced by selecting the reference capacitor C_p that produces the minimum deflection of the balance indicator. By changing the ratio R_1R_2 , it is possible to select the required measurement ranges.

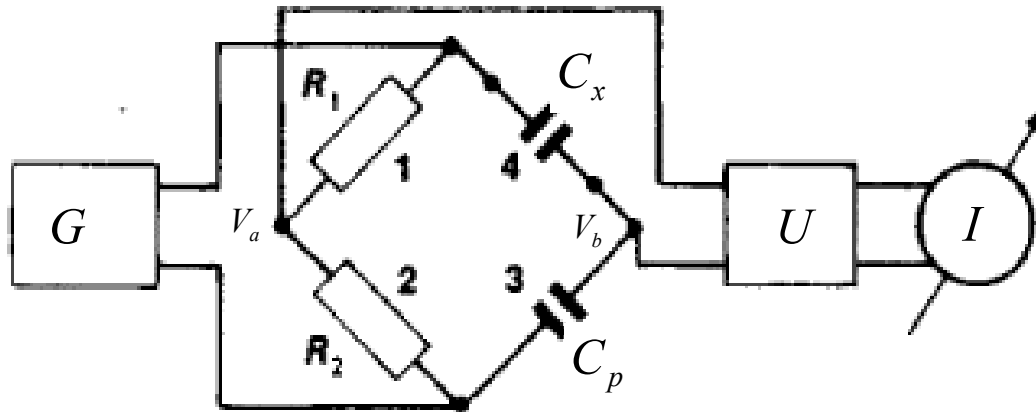

Example

- ▶ If the generator G produces the alternating voltage of V_g , what is the difference between V_a and V_b ?

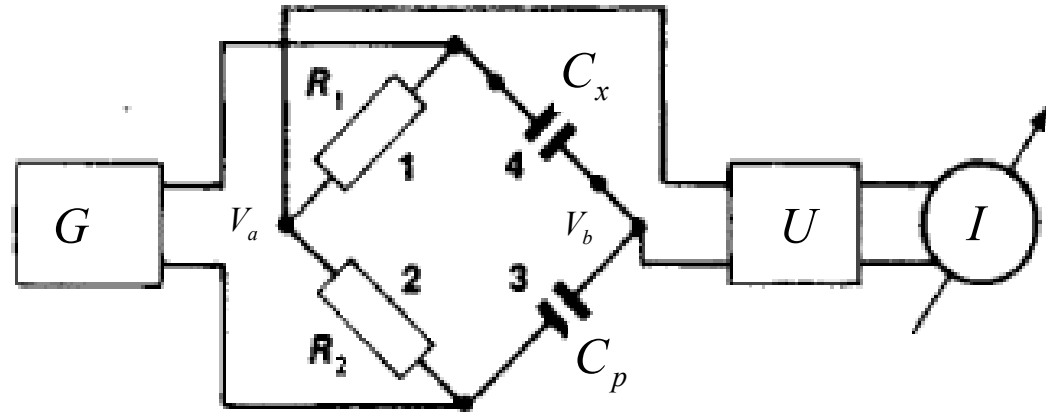

- ▶ Answer:

$$Z_1 = R_1$$

$$Z_3 = \frac{1}{j\omega C_p}$$

$$Z_2 = R_2$$

$$Z_4 = \frac{1}{j\omega C_x}$$

to continue ...

Continued ...

$$V_a - V_b = \left(\frac{Z_2}{Z_1 + Z_2} - \frac{Z_p}{Z_x + Z_p} \right) V_g$$

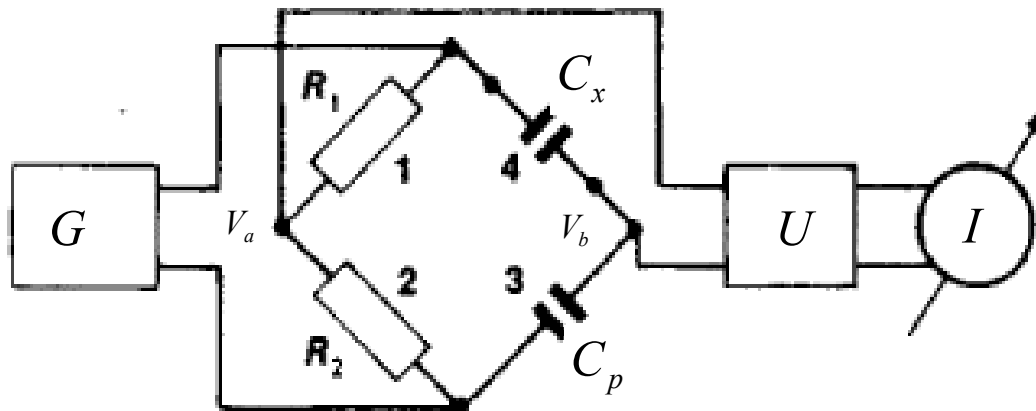

Outline

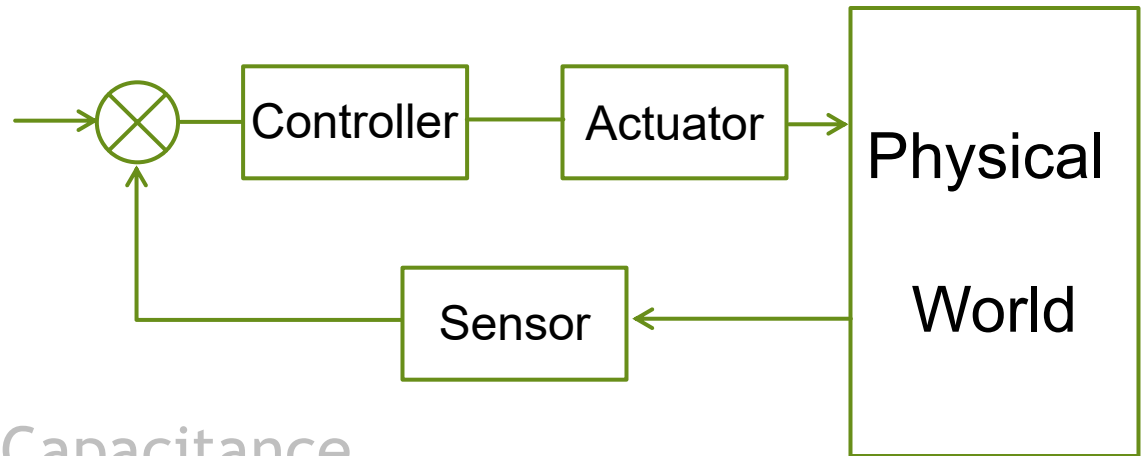

- ▶ Understanding of Capacitance
- ▶ Computation of Capacitance
- ▶ Measurement of Capacitance

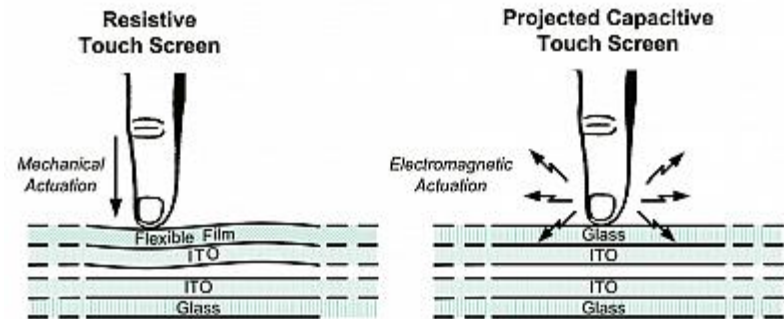

Both **resistive** and **capacitive** technologies have a strong electrical component, both use ITO (Indium-Tin-Oxide, a clear conductor), and both will be around for a long time to come. A **resistive** touchscreen consists of a **flexible** top layer, then a layer of ITO (Indium-Tin-Oxide), an air gap and then another layer of ITO.

Applications in Electronic Circuits

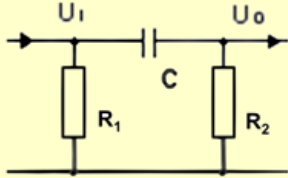
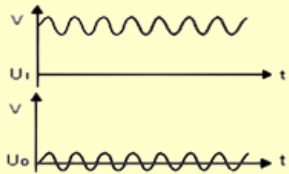
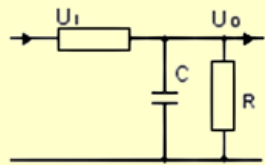
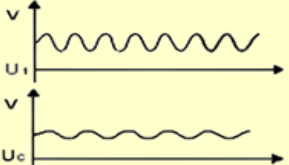
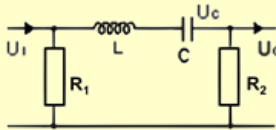
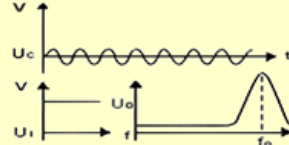
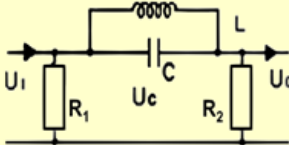
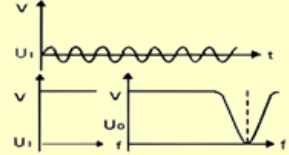
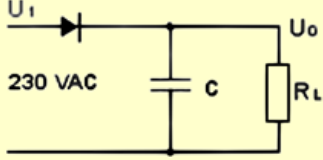
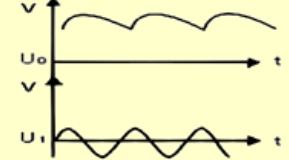
Capacitor purpose	Circuit application	Waveform	Capacitor requirements
Coupling or blocking			High insulation resistance. Correct voltage, Low self-inductance
Decoupling or bypassing			High insulation resistance, Low self-inductance
Filtering Pass filter			Low dissipation factor, Stable capacitance
Filtering Stop filter			Low dissipation factor, Stable capacitance.
Smoothing			Comparably high capacitance, Low dissipation factor

Applications in Touch Screens

• Capacitance formed when finger approaches

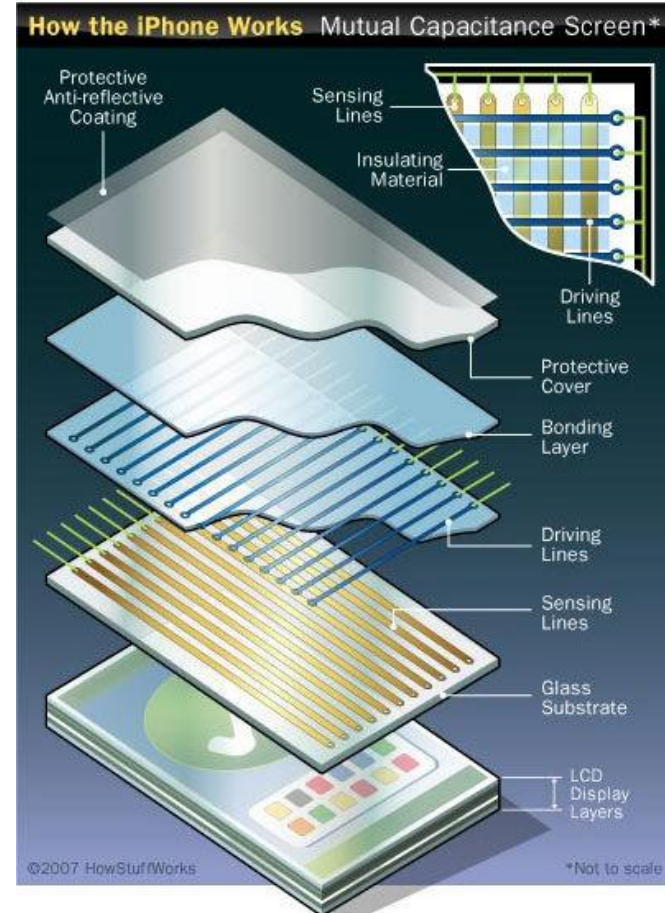
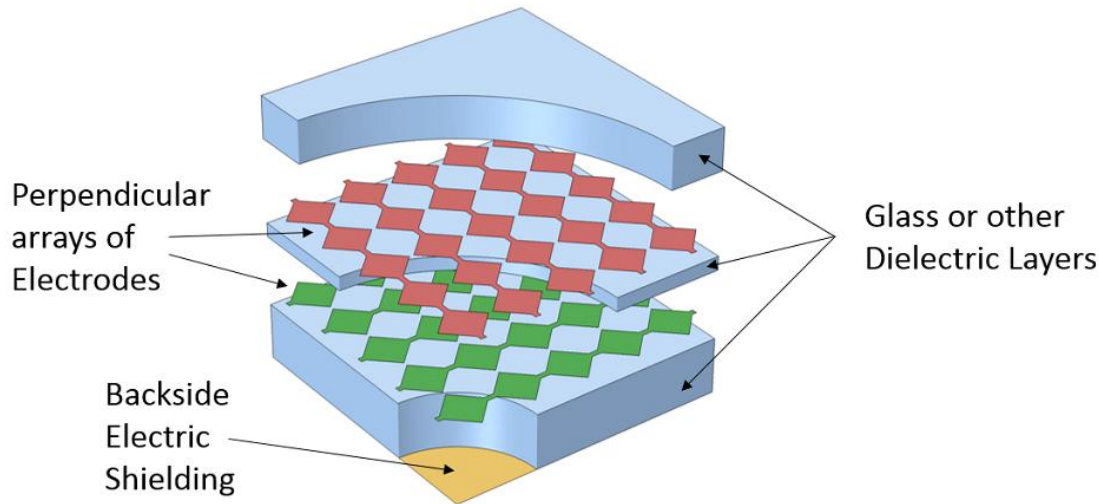
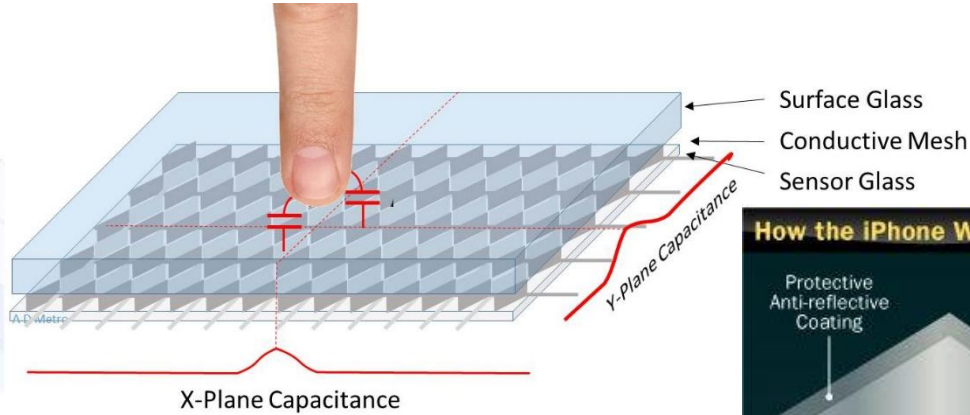
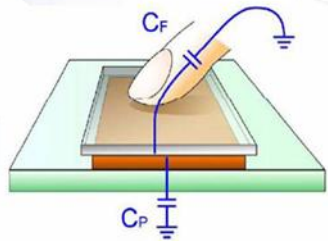

Applications in Force/Torque Sensors

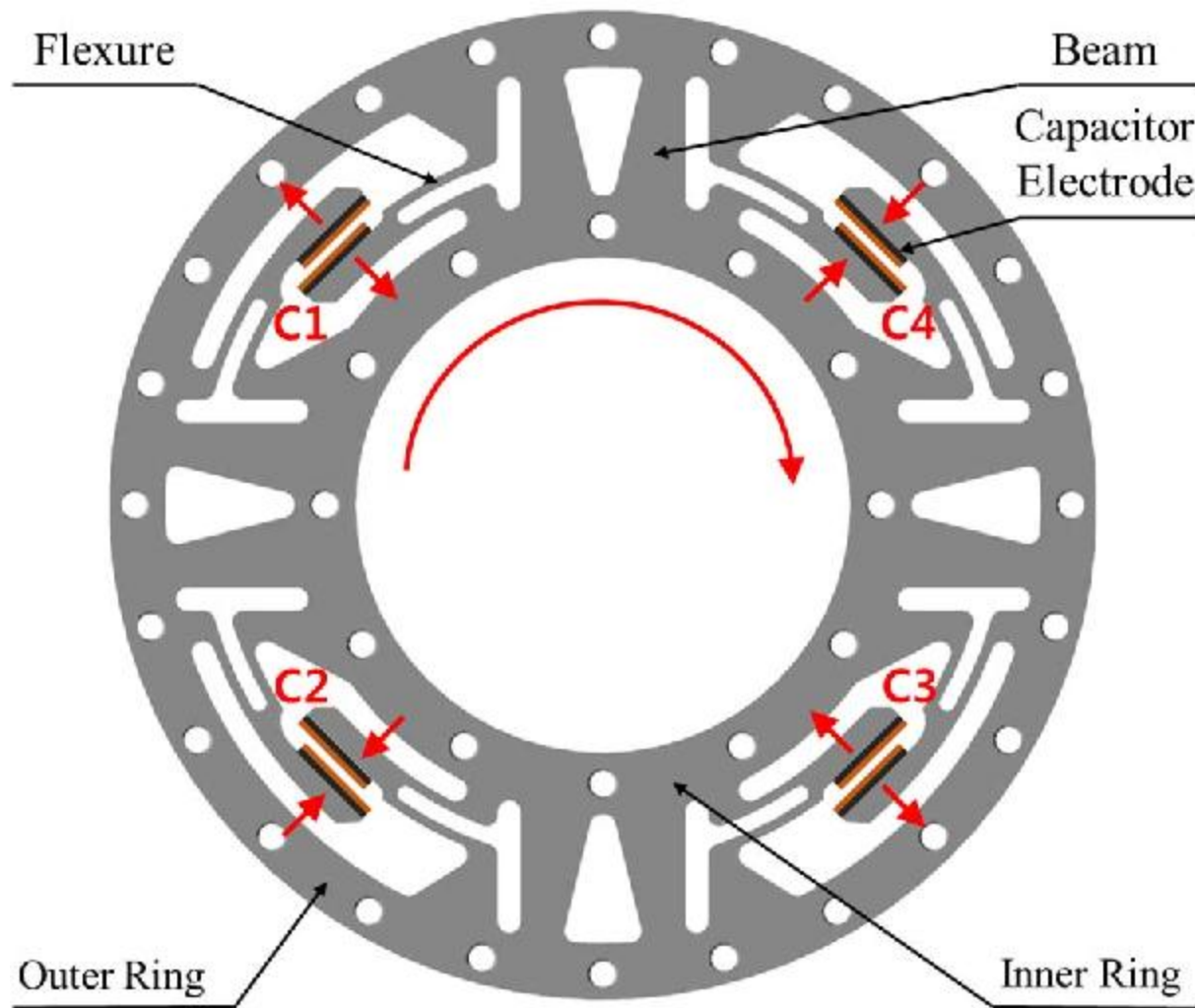

Applications in Acceleration Sensors

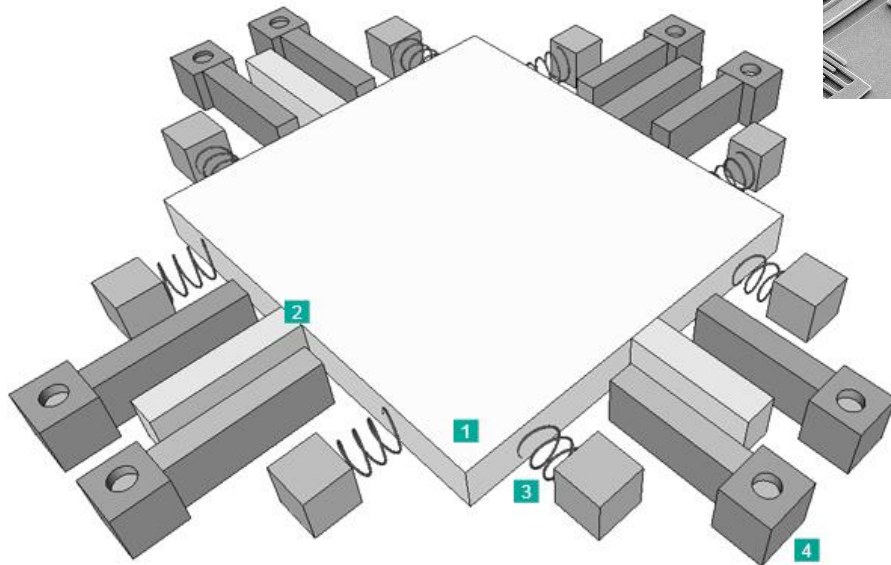
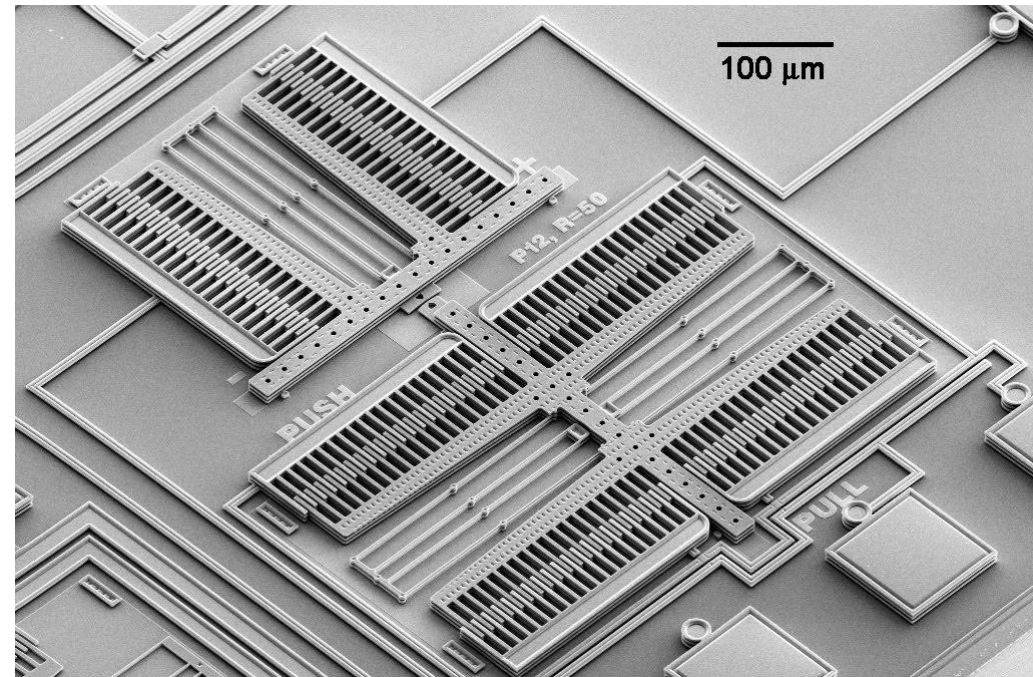

Principles of Measuring Capacitance

- ▶ Electric voltage can be automatically measured.
- ▶ Electric current can be automatically measured.
- ▶ Electric capacitance could be related to voltage or current.
- ▶ Hence, electric capacitance can also be automatically measured.

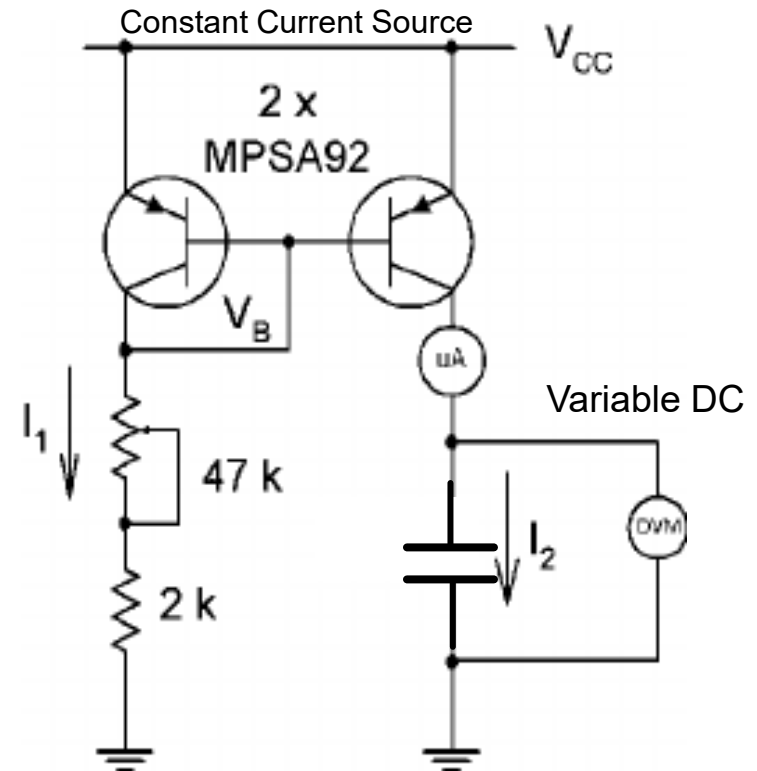

$$i = C \frac{dv}{dt} \quad \Rightarrow \quad v(t) = \frac{I_2}{C} t$$

How to design digital measurement and sensing systems for capacitance?

- ▶ Capacitance is converted to voltage which is measured by digital voltmeter (e.g. microcontrollers).

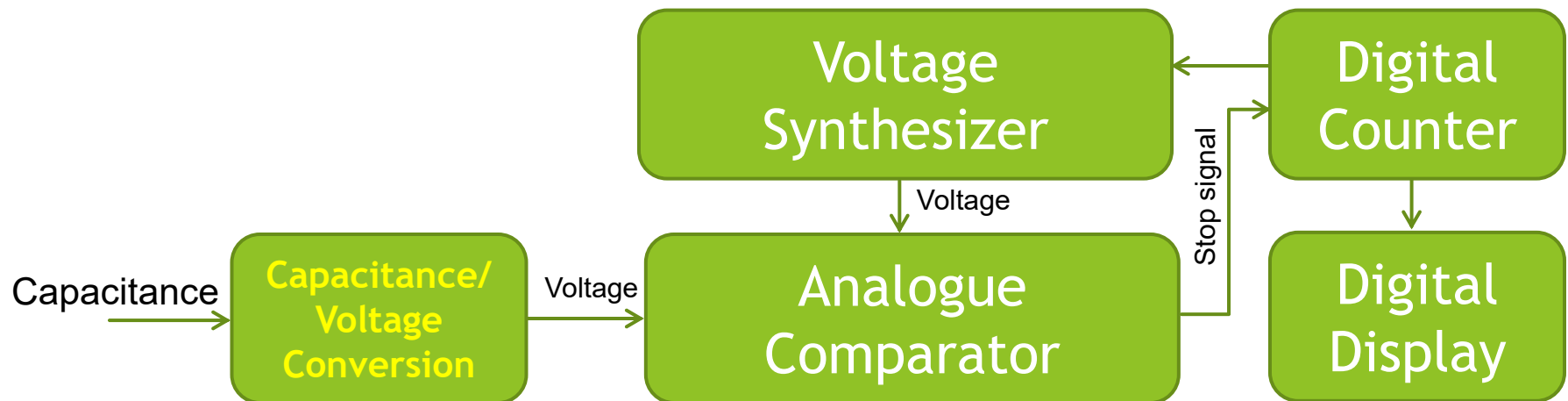

All microcontrollers are programmable digital sensors of voltage!

How to convert capacitance into AC or variable voltage?

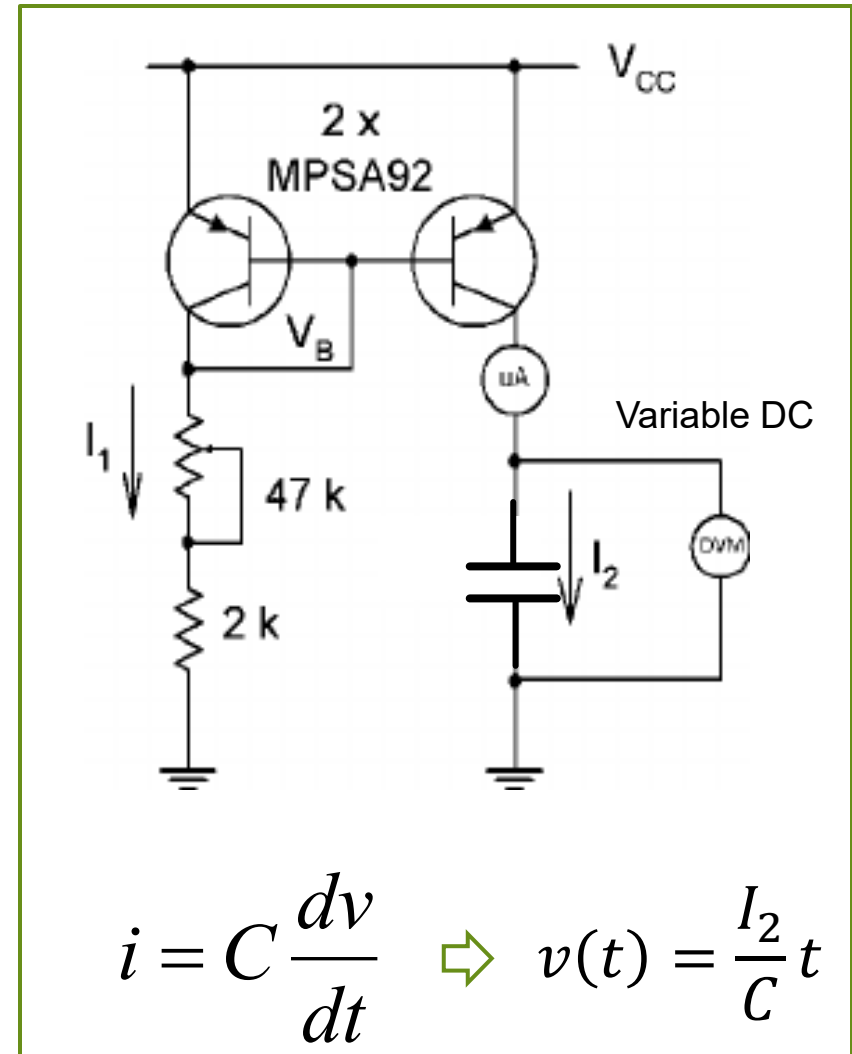
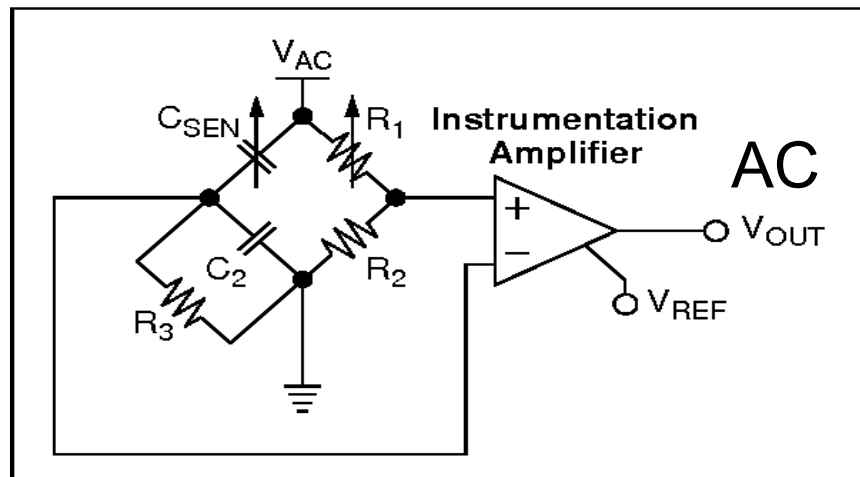
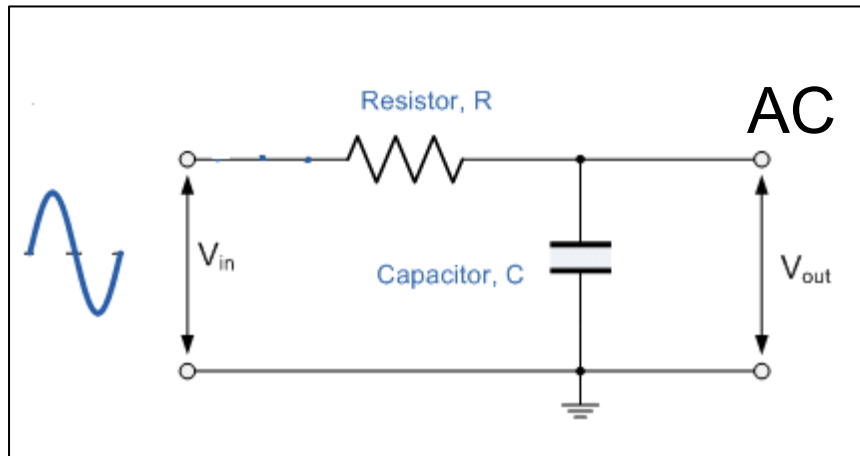

$$i = C \frac{dv}{dt} \Rightarrow v(t) = \frac{I_2}{C} t$$

Example of Converting Capacitance into AC Voltage

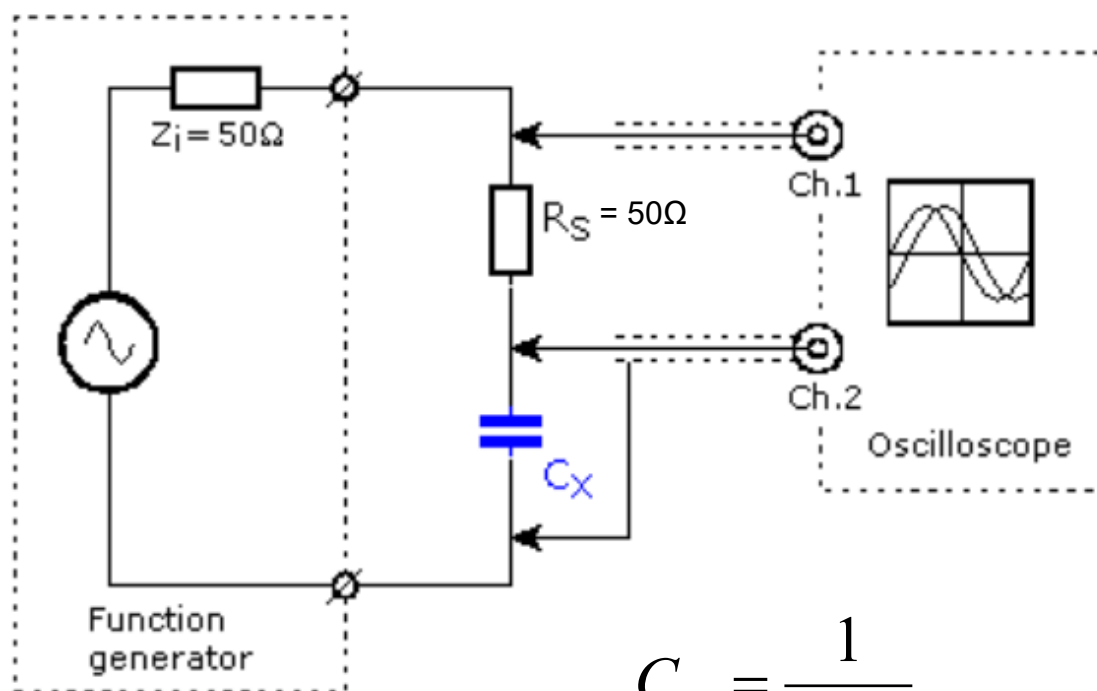

$$C_x = \frac{1}{\omega Z_x}$$

$$\omega = 2\pi f$$

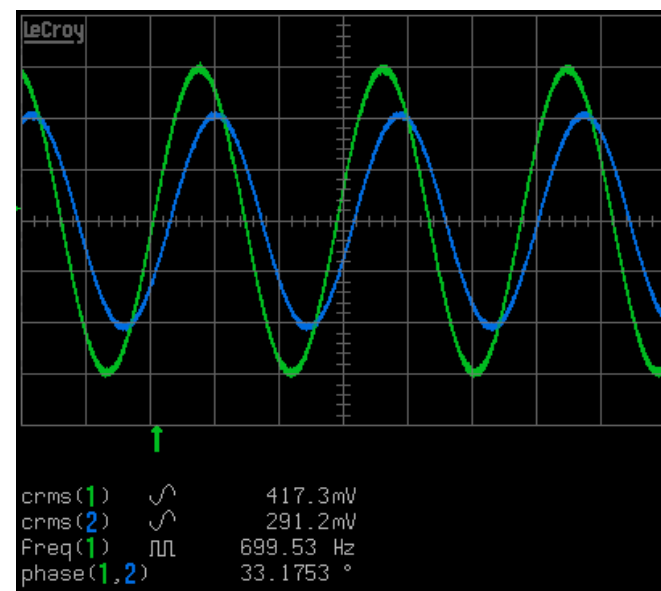
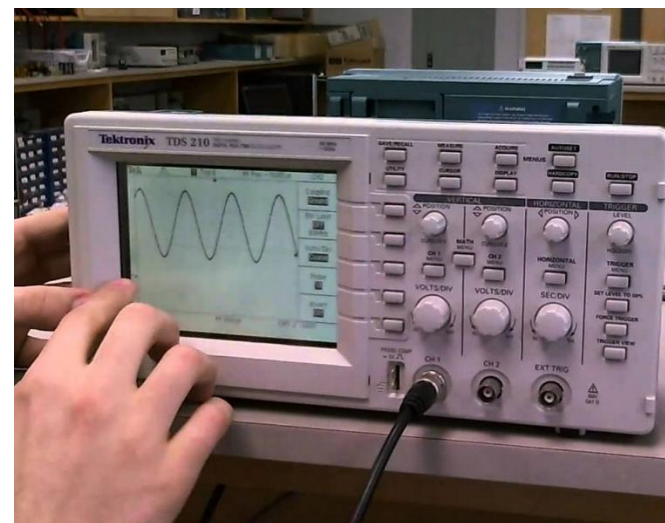

How to convert AC voltages into DC voltages?

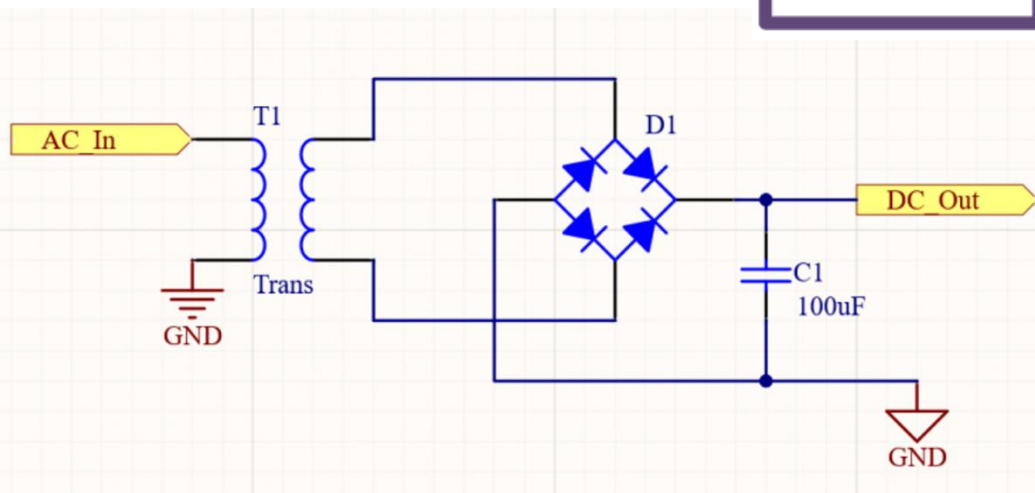
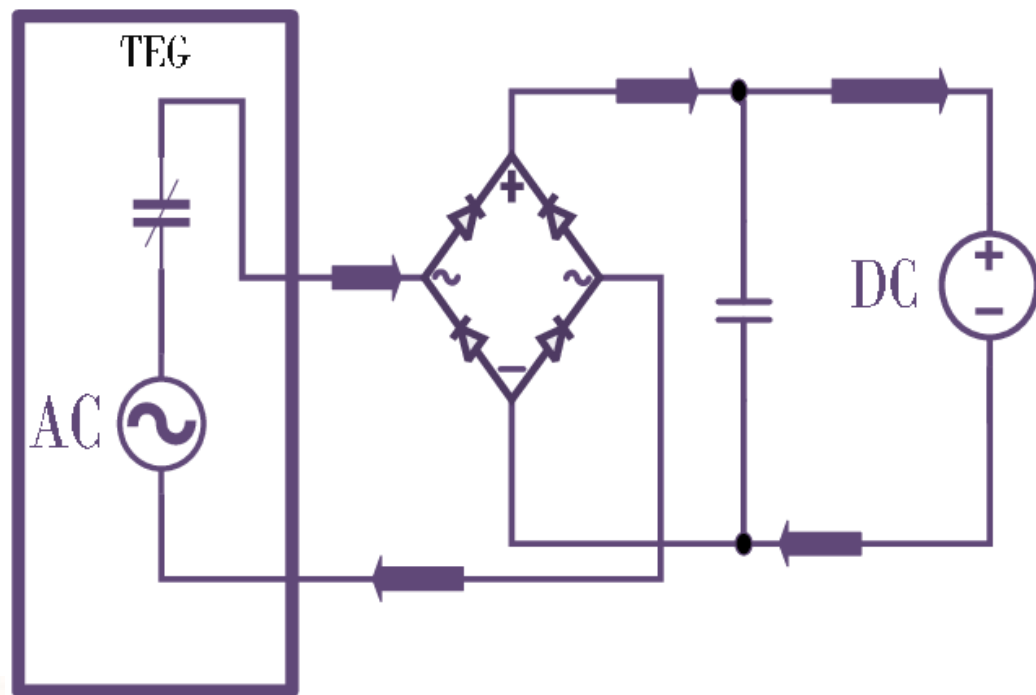

Remember to Do Calibration

- ▶ Curve fitting for calibration:
 - ▶ Y_i is produced by X_i
 - ▶ Z_i is computed from Y_i
 - ▶ Z_i must be equal to X_i

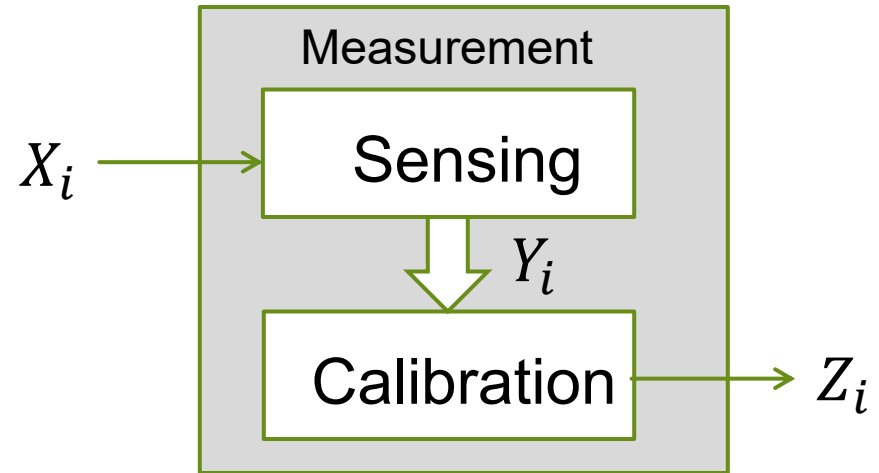

Calibrated Values Z_i

Measured Values Y_i

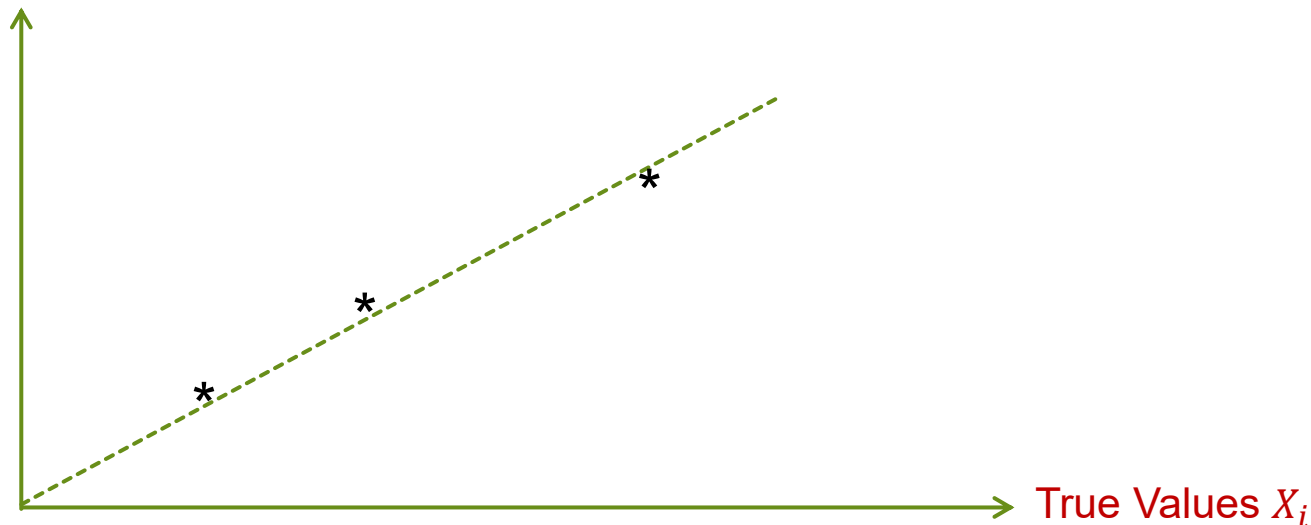

Remember to Do Error Analysis

- ▶ Systematic error = mean value - true value
- ▶ Repeatability error = value with maximum error - mean value
- ▶ Accuracy = value with minimum error - mean value
- ▶ Hysteresis error = |measured value in increasing - measured value in decreasing|

For each true value, we can do error analysis

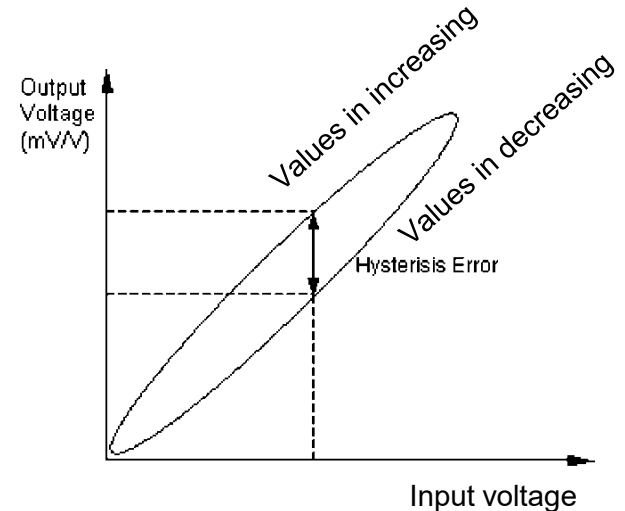
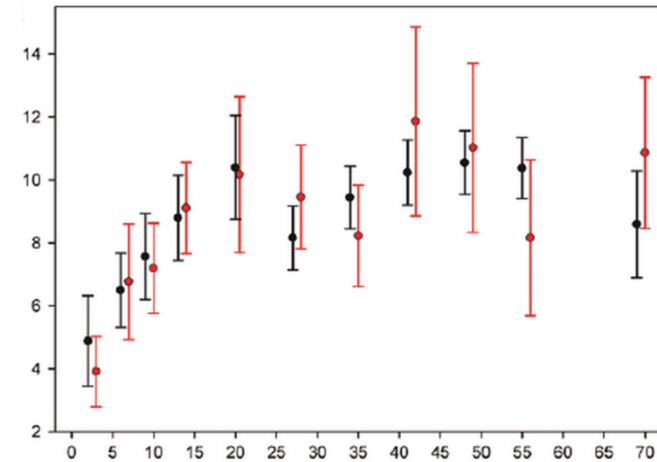

Summary

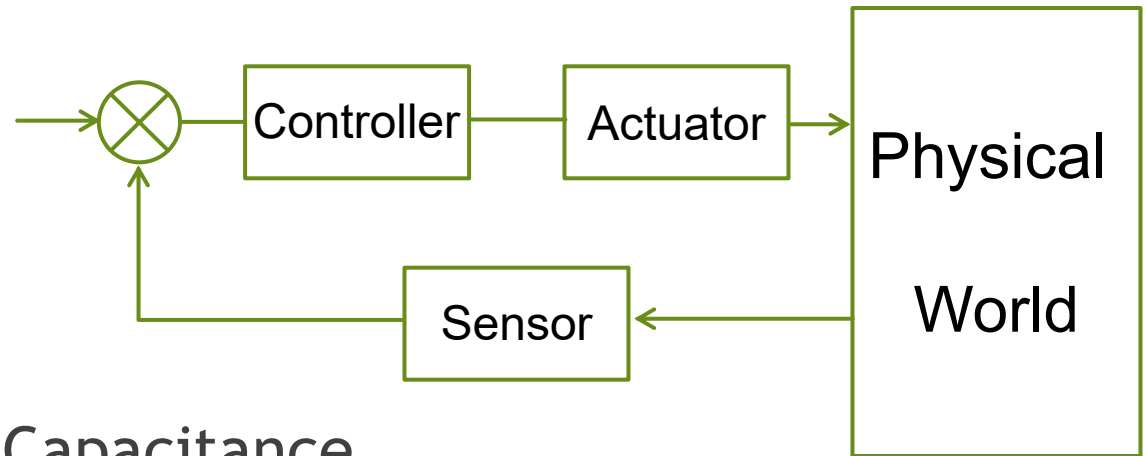

- ▶ Understanding of Capacitance
- ▶ Computation of Capacitance
- ▶ Measurement of Capacitance

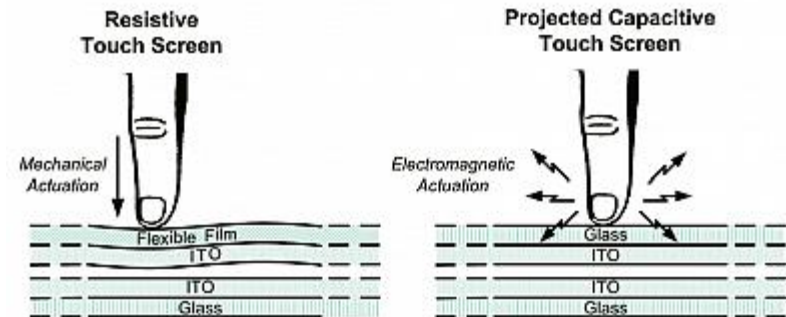

Both **resistive** and **capacitive** technologies have a strong electrical component, both use ITO (Indium-Tin-Oxide, a clear conductor), and both will be around for a long time to come. A **resistive** touchscreen consists of a **flexible** top layer, then a layer of ITO (Indium-Tin-Oxide), an air gap and then another layer of ITO.

Outline of Module 2

- ▶ Lecture 1:
 - ▶ Measurement of Voltage
- ▶ Lecture 2:
 - ▶ Measurement of Current
- ▶ Lecture 3:
 - ▶ Measurement of Resistance
- ▶ Lecture 4:
 - ▶ Measurement of Capacitance
- ▶ Lecture 5:
 - ▶ Measurement of Inductance

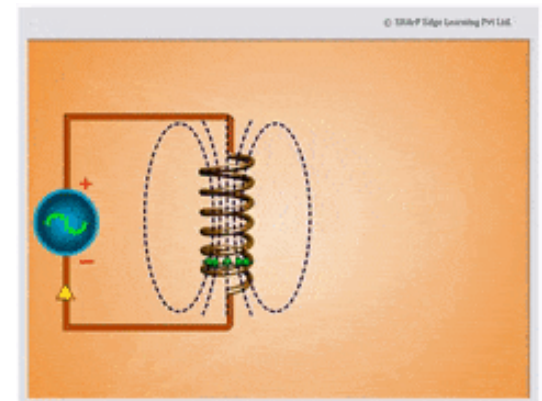
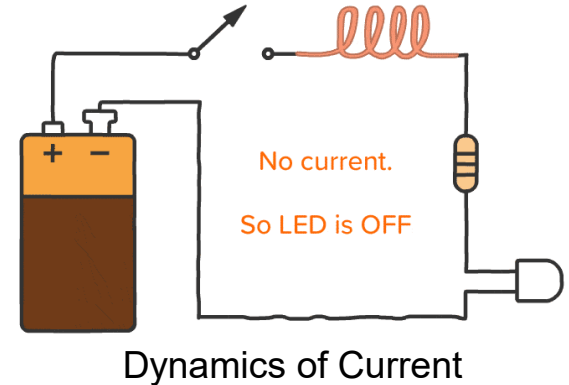
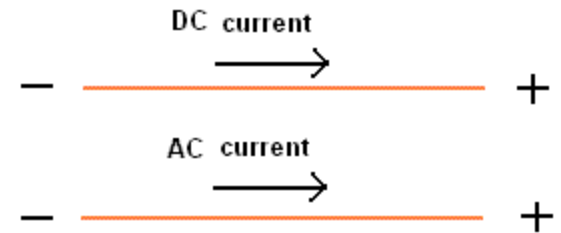



**NANYANG
TECHNOLOGICAL
UNIVERSITY**

School of Mechanical & Aerospace Engineering

Design, Machine, Control, Intelligence

Module 2 Lecture 5

MA4822

Measurement of Inductance

Xie Ming, PhD (France)

mmxie@ntu.edu.sg

<http://personal.ntu.edu.sg/mmxie>

Outline

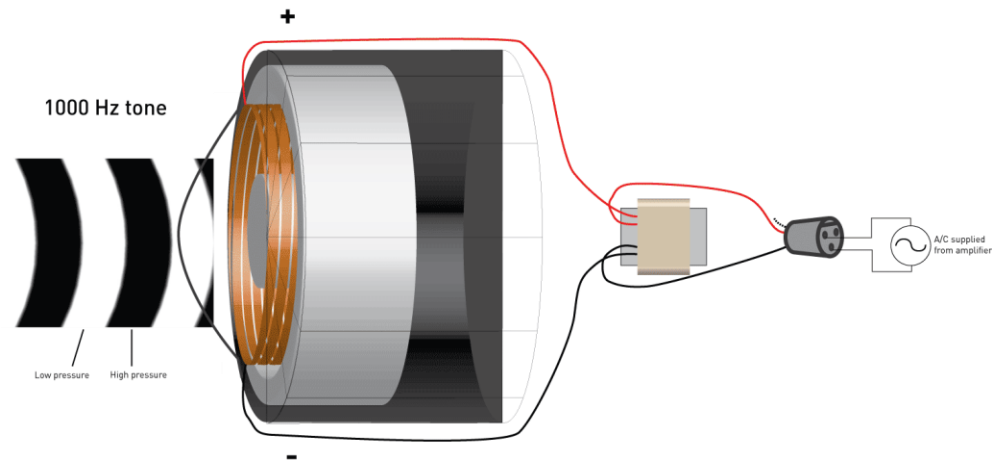

► Understanding of Inductance

► Computation of Inductance

► Measurement of Inductance

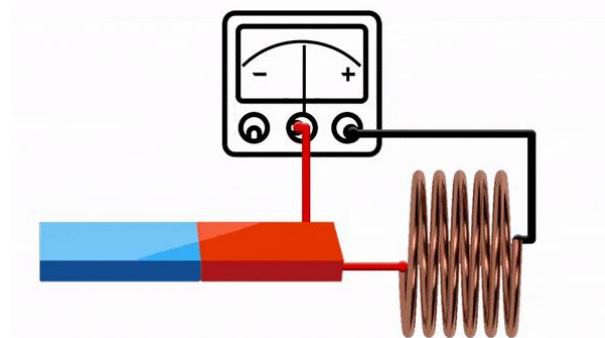

Outline

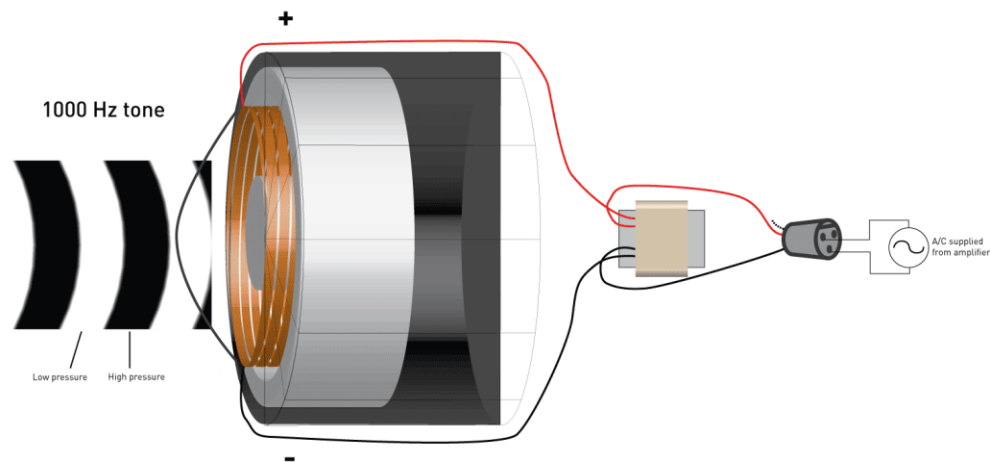

► Understanding of Inductance

► Computation of Inductance

► Measurement of Inductance

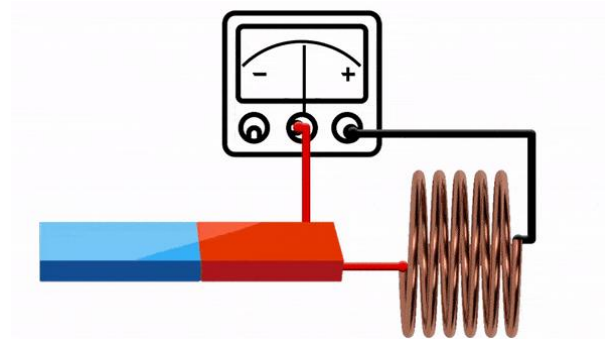

What is inductor?



Definition of Inductor

- ▶ An **inductor**, also called a **coil** or **reactor**, is a passive two-terminal electrical component which resists changes in electric current passing through it.
- ▶ An **inductor** is a device which could **induce** magnetic field.
- ▶ An inductor consists of a conductor such as a wire, usually wound into a coil.

Example of Making Inductors

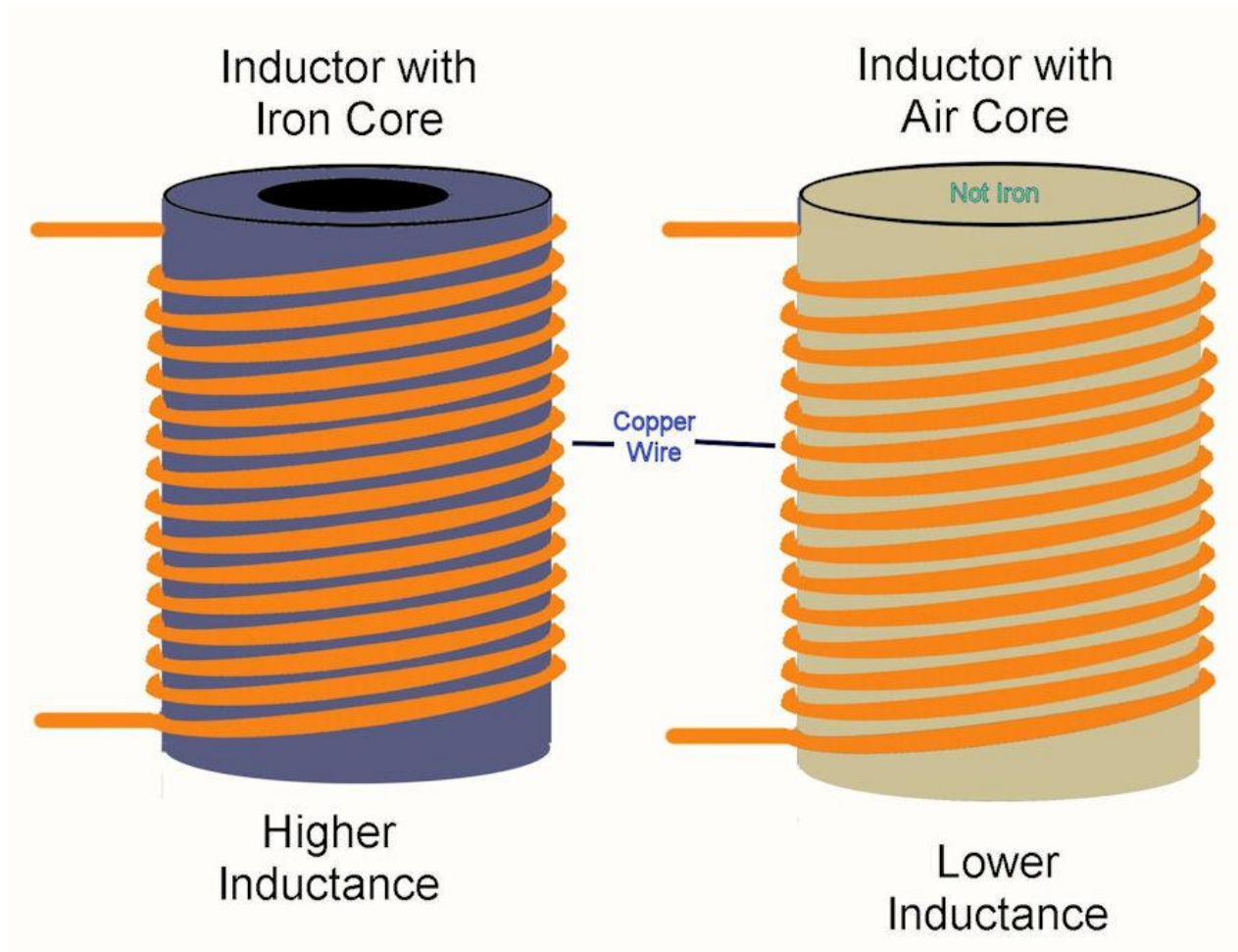

Graphic Representation of Inductor

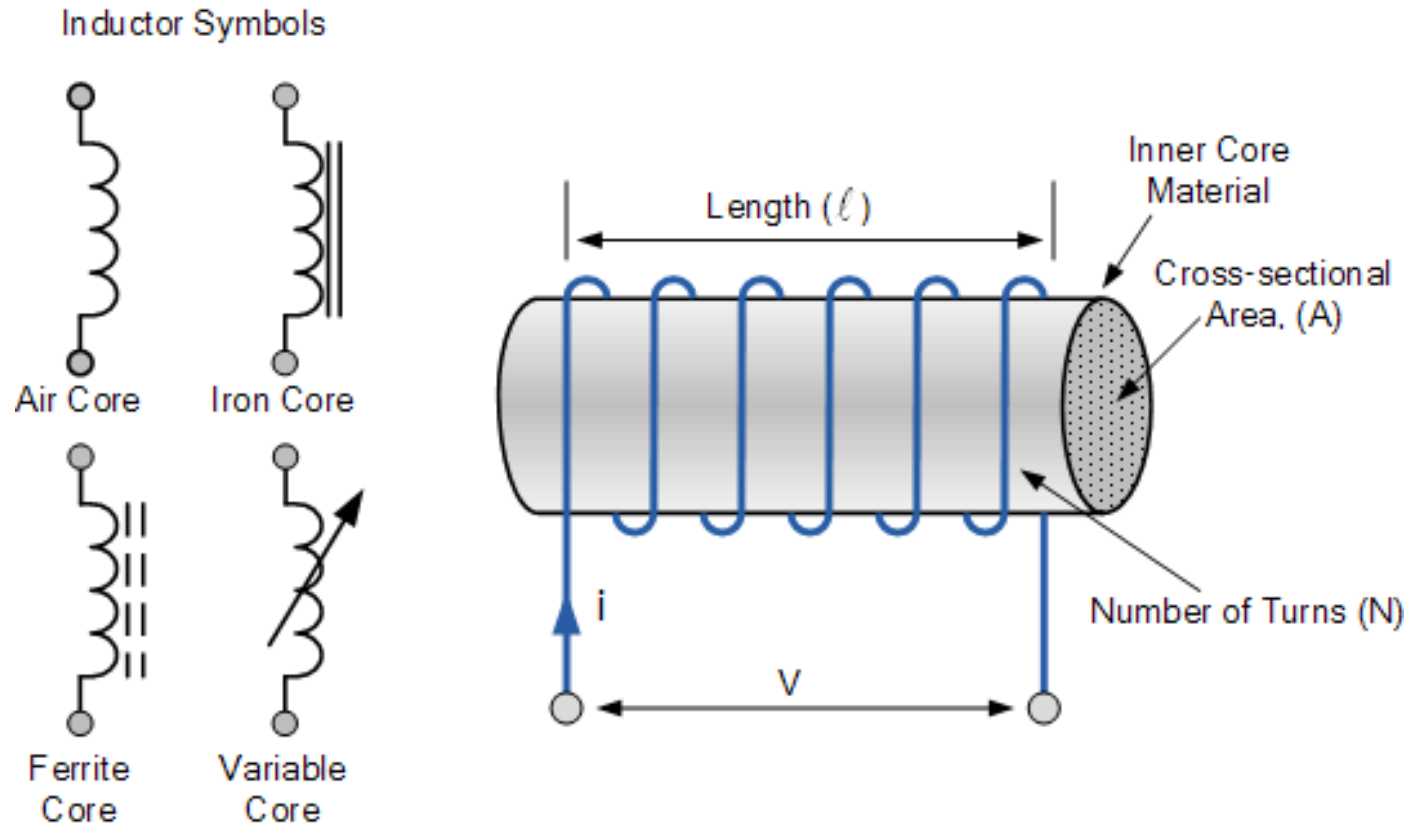

Examples of Graphic Representations

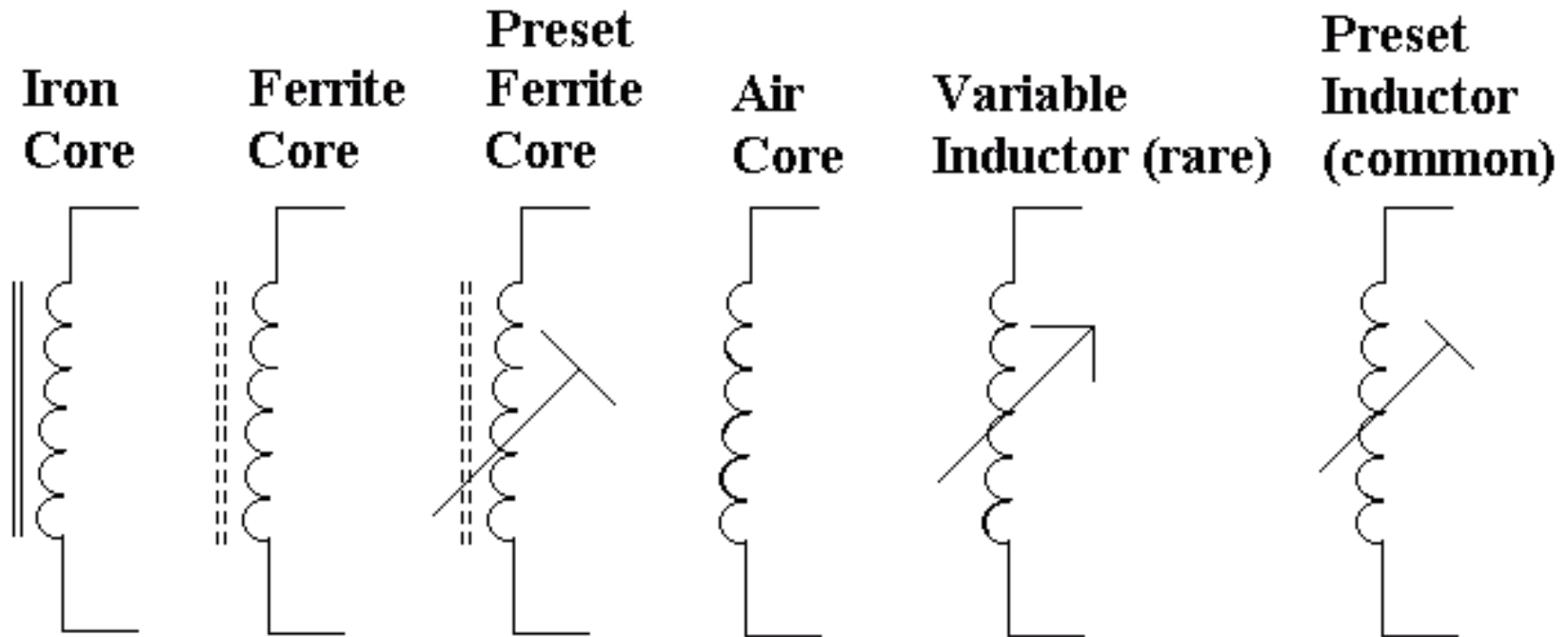

Physical Parameters of Inductor

- ▶ Inductance
- ▶ Number of Turns
- ▶ Cross-Sectional Area
- ▶ Length
- ▶ Inner Core Material

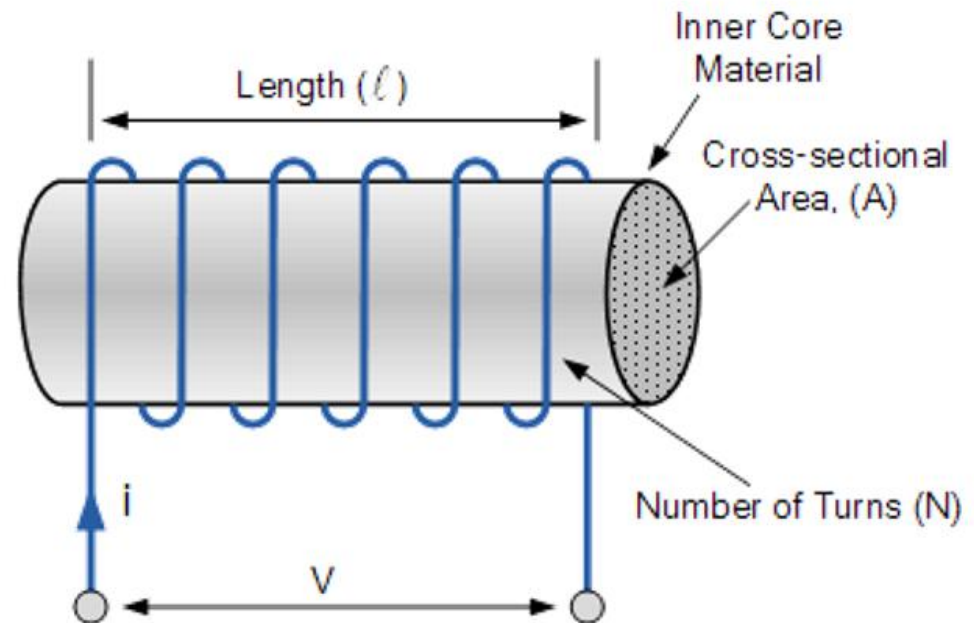

Definition of Inductance

- ▶ Inductance refers to the ability for an inductor to induce magnetic flux by electric current.

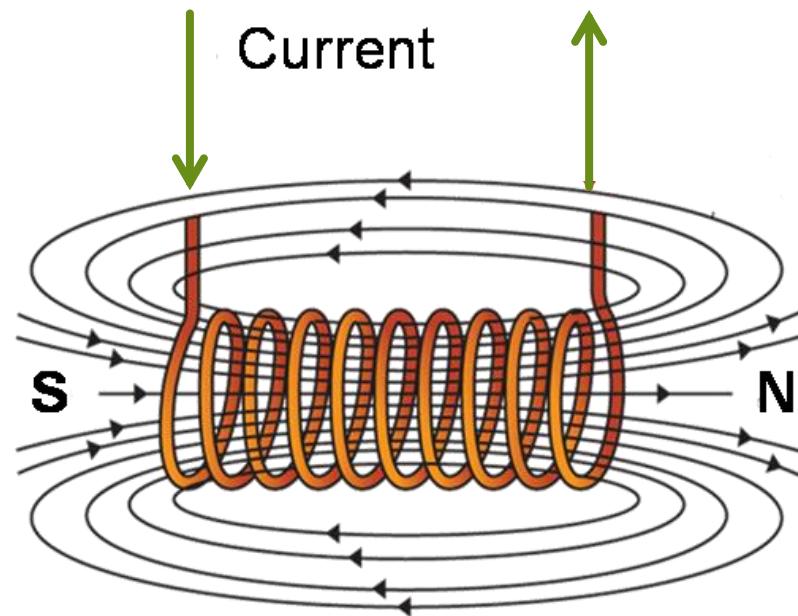

Ohm's Law for Inductor

$$\phi = L \times i$$

$$d\phi = L \times di$$

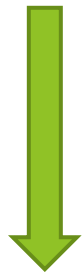

$$v = \frac{d\phi}{dt}$$

Voltage induced by the change rate of magnetic flux inside a coil or loop

$$v = L \frac{di}{dt}$$

Simple a.c. Generator

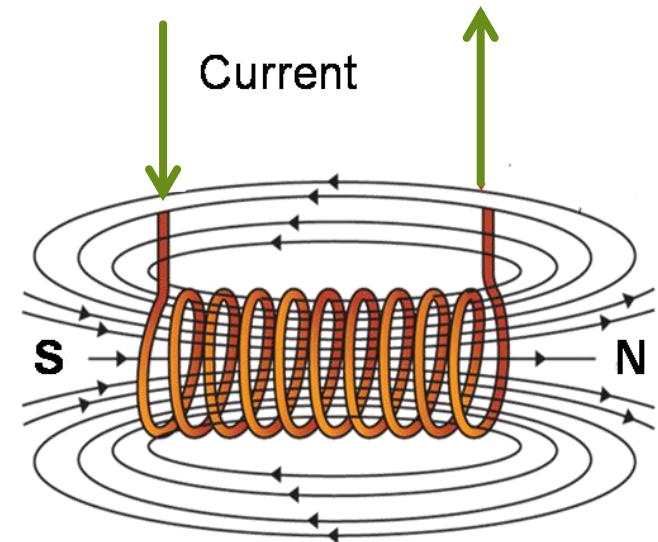
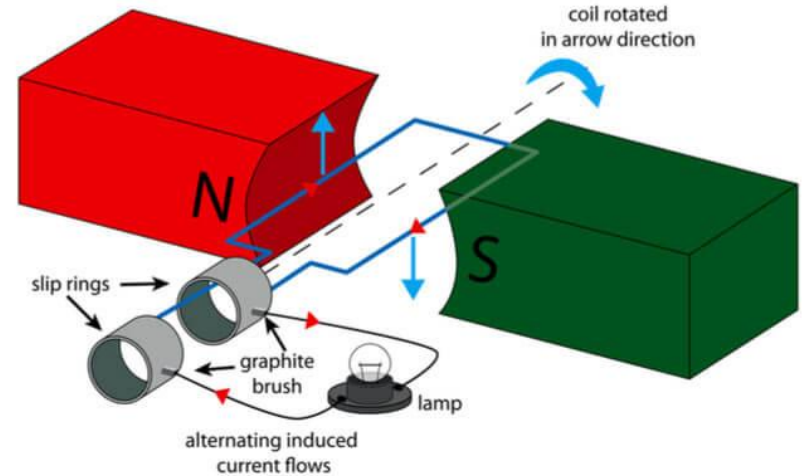

Outline

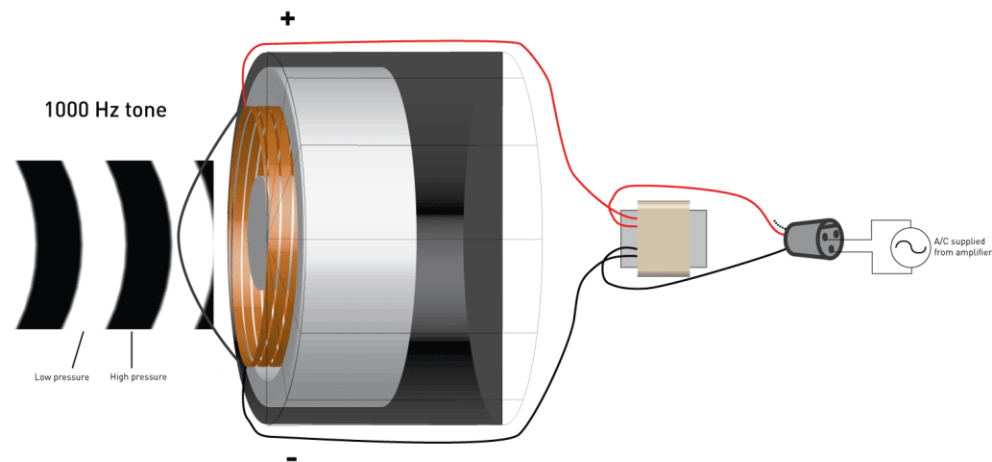

► Understanding of Inductance

► Computation of Inductance

► Measurement of Inductance

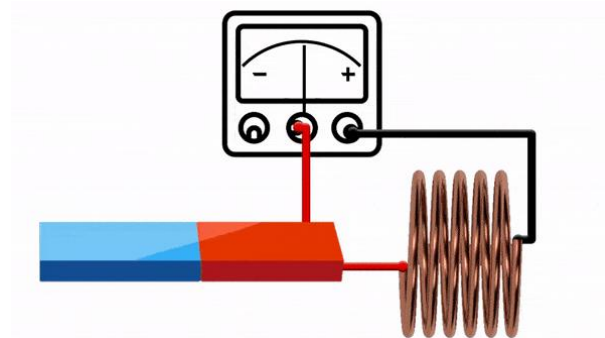

Unit of Measurement of Inductance

- ▶ The henry (symbol H) is the unit of electrical inductance in the International System of Units. The unit is named after Joseph Henry (1797-1878), the American scientist who discovered electromagnetic induction independently of and at about the same time as Michael Faraday (1791-1867) in England.

$$v = L \frac{di}{dt}$$

$$L(\text{HENRYS}) = \frac{\text{Voltage Across Inductor (VOLTS)}}{di/dt \text{ (amps/seconds)}}$$

Other Related Units of Measurement

Parameter	Measuring Unit	Relationship
Voltage	volt (V or E)	$E = I \times R$
Current	amp (I)	$I = \frac{E}{R}$
Resistance	ohm (R or Ω)	$R = \frac{E}{I}$
Conductance	mho (G or \mathcal{U})	$G = \frac{I}{R} = \frac{I}{E}$
Power	watt (W)	$P = I \times E$ or $P = I^2R$
Inductance	henry (L or H)	$V_L = -L \left(\frac{\Delta I}{\Delta t} \right)$
Capacitance	farad (C)	$C = \frac{Q}{E}$ (Q = charge)

Inductor's Colour Code Chart

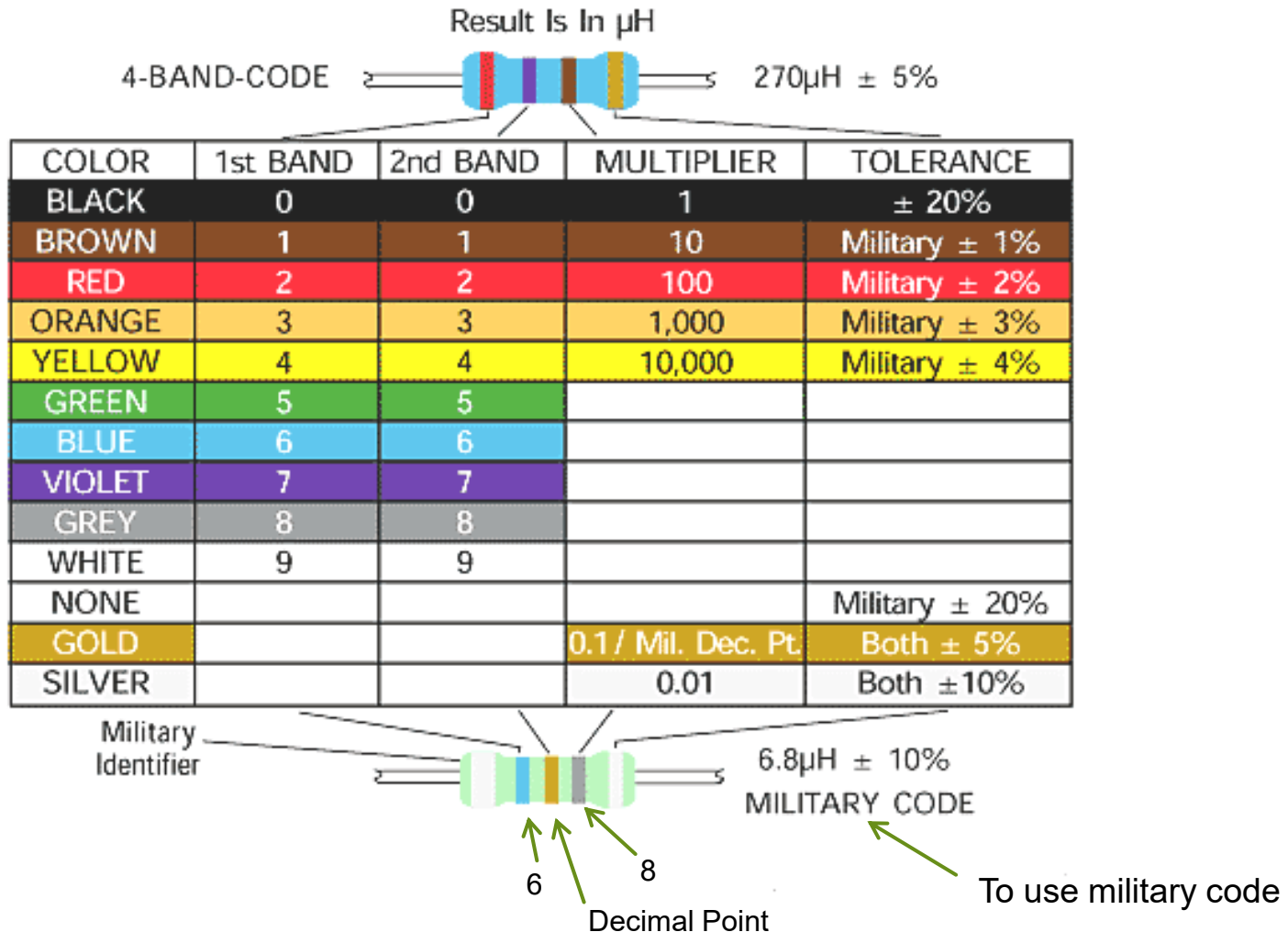

Example

COLOR	1st BAND	2nd BAND	MULTIPLIER	TOLERANCE
BLACK	0	0	1	± 20%
BROWN	1	1	10	Military ± 1%
RED	2	2	100	Military ± 2%
ORANGE	3	3	1,000	Military ± 3%
YELLOW	4	4	10,000	Military ± 4%
GREEN	5	5		
BLUE	6	6		
VIOLET	7	7		
GREY	8	8		
WHITE	9	9		
NONE				Military ± 20%
GOLD			0.1 / Mil. Dec. Pt.	Both ± 5%
SILVER			0.01	Both ± 10%

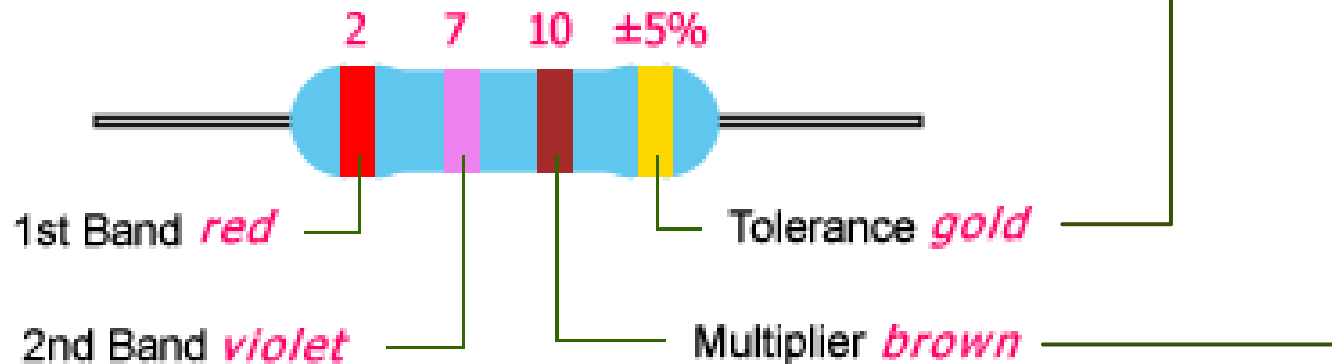

A 270µH Inductor

27 × 10 µH with a tolerance rating of ± 5%

Inductors Could Be Connected in Series

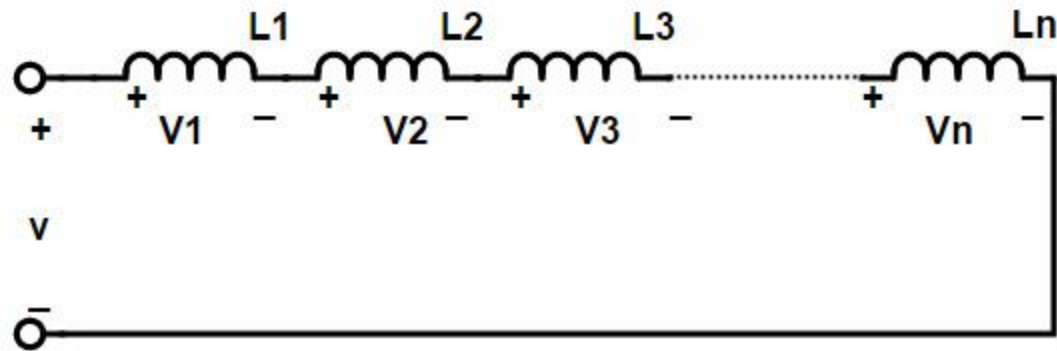

$$L_{equal} = L_1 + L_2 + \dots + L_n$$

Inductors Could Be Connected in Parallel

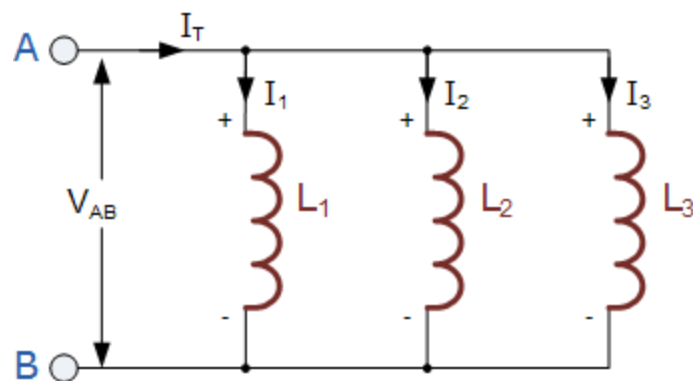

$$\frac{1}{L_{equal}} = \frac{1}{L_1} + \frac{1}{L_2} + \dots + \frac{1}{L_n}$$

Dynamics of Inductor ...

- Transient response
- Steady-state response

Idea of measuring L?

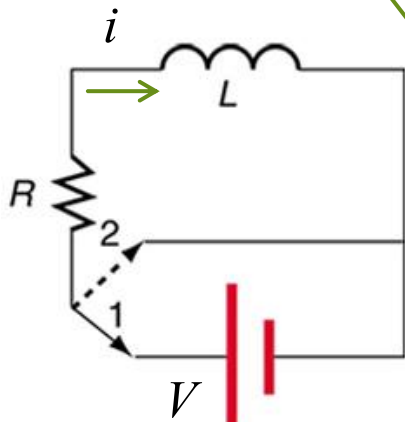

(a)

Switch to 1

$$V = iR + L \frac{di}{dt}$$

$$i = \frac{V}{R} (1 - e^{-tR/L})$$

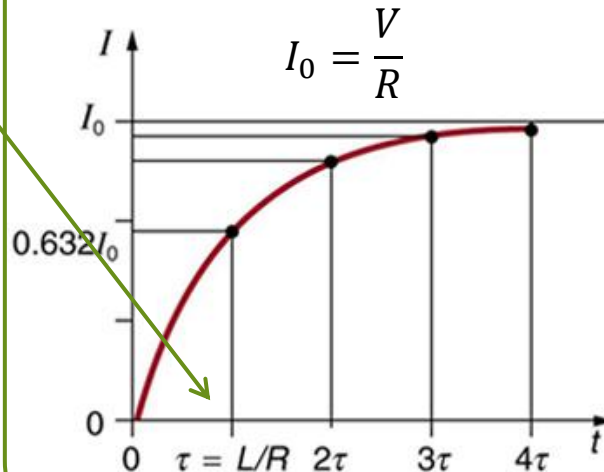

(b)

Switch to 2

$$iR + L \frac{di}{dt} = 0$$

$$i = \frac{V}{R} e^{-tR/L}$$

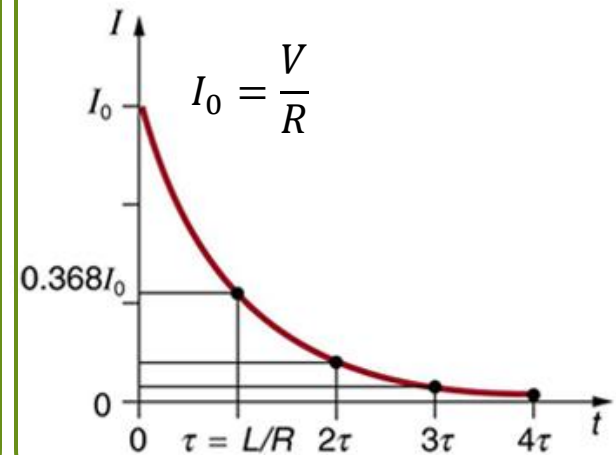

(c)

Example

- Transient response
- Steady-state response

► In a RL circuit, when the loop is closed, what is the time function of voltage across the inductor?

► Answer:

$$V_b = iR + L \frac{di}{dt}$$

$$i = \frac{V_b}{R} (1 - e^{-tR/L})$$

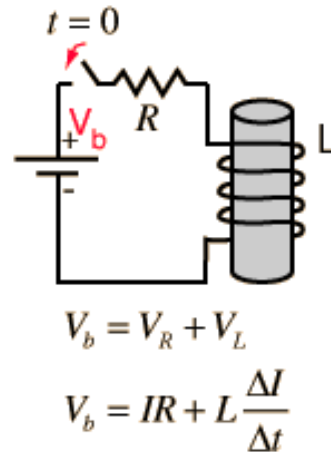

As the current increases

$$V_b = IR + L \frac{\Delta I}{\Delta t}$$

the rate of change of current decreases.

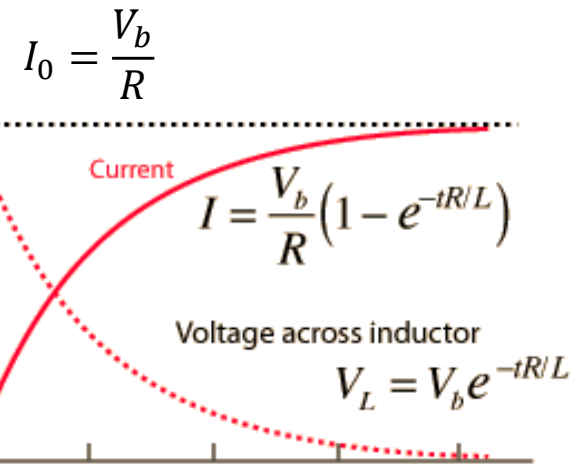

At time $I = 0$
 $t = 0$ $V_R = 0$
 $V_L = V_b$

As $t \rightarrow \infty$
 $I \rightarrow \frac{V_b}{R}$
 $V_R \rightarrow V_b$

Time constant $\tau = \frac{L}{R}$

Continued ...

$$V_L = L \frac{di}{dt}$$



$$i = \frac{V_b}{R} (1 - e^{-tR/L})$$

$$V_L = V_b e^{-tR/L}$$

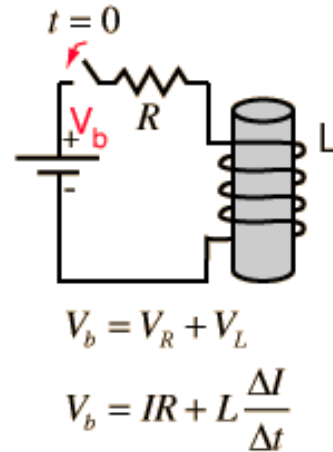

As the current increases

$$V_b = IR + L \frac{\Delta I}{\Delta t}$$

the rate of change of current decreases.

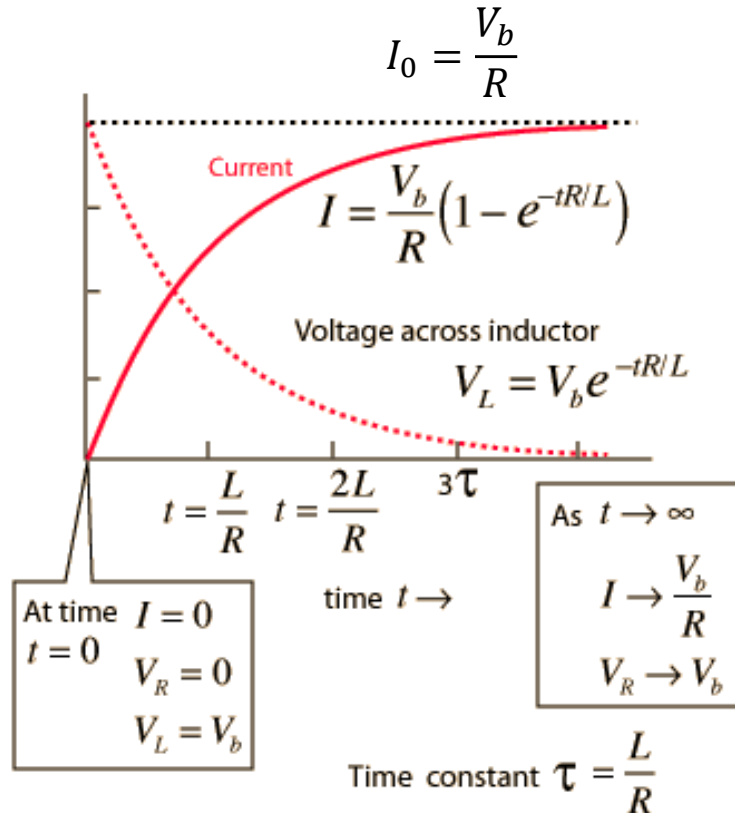

Frequency Response of Inductor ...

► Diagram:

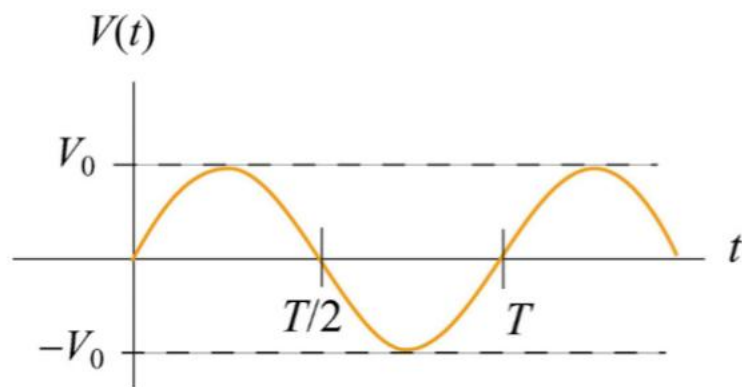

$$\omega = 2\pi f \quad \omega = \frac{2\pi}{T}$$

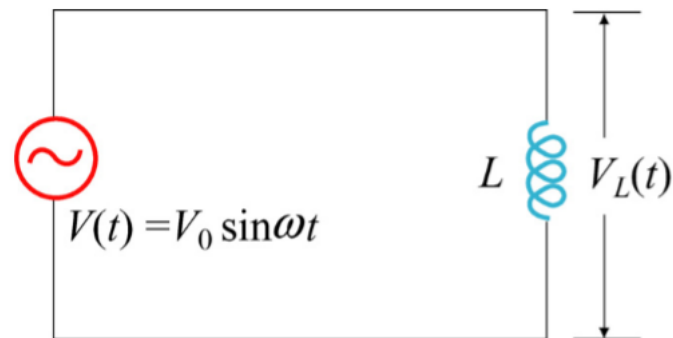

- Frequency response

Frequency Response of Inductor ...

- Kirchhoff's Voltage Rule:

$$V(t) - V_L(t) = 0$$

$$V(t) - L \frac{dI(t)}{dt} = 0$$

$$I(t) = \frac{1}{L} \int V(t) dt = \frac{1}{L} \int V_0 \sin(\omega t) dt$$

$$I(t) = -\frac{V_0}{\omega L} \cos(\omega t) = \frac{V_0}{\omega L} \sin\left(\omega t - \frac{\pi}{2}\right)$$

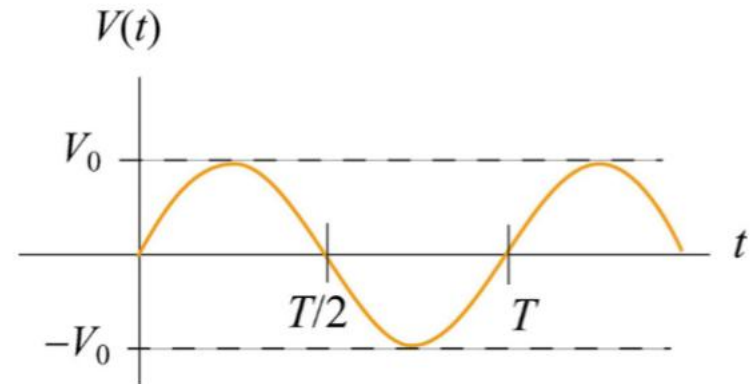

- Frequency response

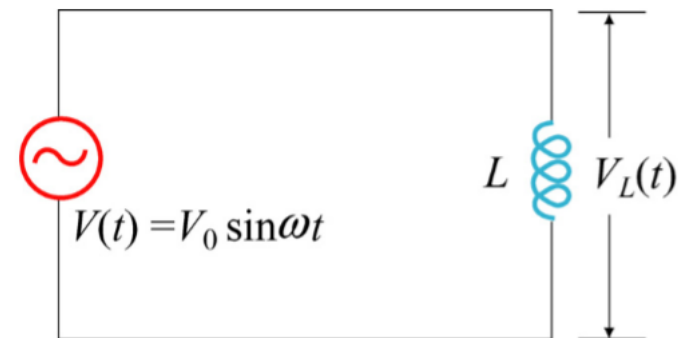

Frequency Response of Inductor ...

► Inductor's Resistance:

$$I(t) = \frac{V_0}{\omega L} \sin\left(\omega t - \frac{\pi}{2}\right) = I_0 \sin\left(\omega t - \frac{\pi}{2}\right)$$

$$I_0 = \frac{V_0}{\omega L} = \frac{V_0}{Z_L}$$

$$Z_L = \omega L$$

↑ It is called Inductor's Resistance

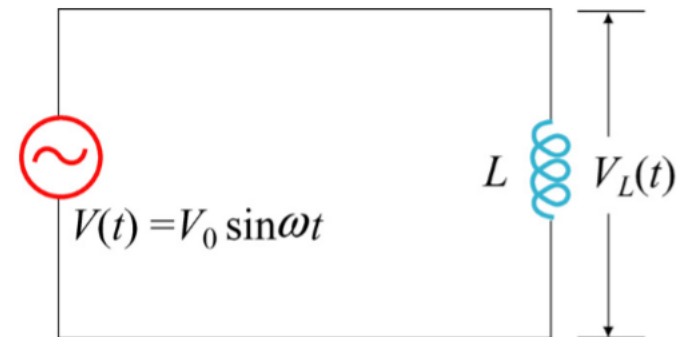
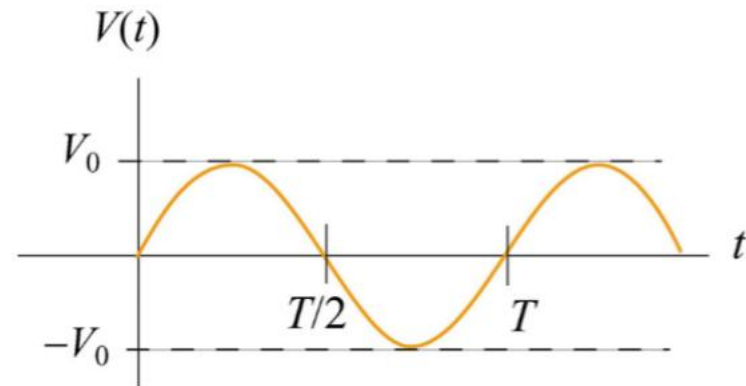

Impedance = {Resistance, Reactance}

Frequency Response:

Impedance = {Resistance, Reactance}

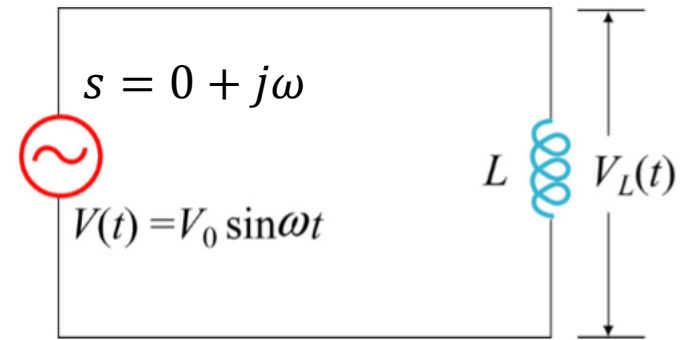

► Phasor Diagram:

Frequency Domain

$$V(t) = L \frac{dI(t)}{dt} \Rightarrow \frac{I(s)}{V(s)} = \frac{1}{Ls} \Rightarrow \frac{I(j\omega)}{V(j\omega)} = \frac{1}{j\omega L}$$

Impedance

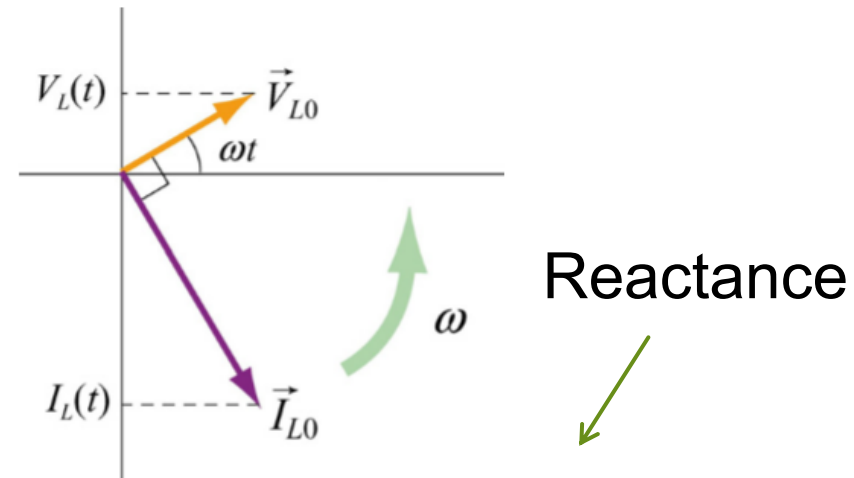
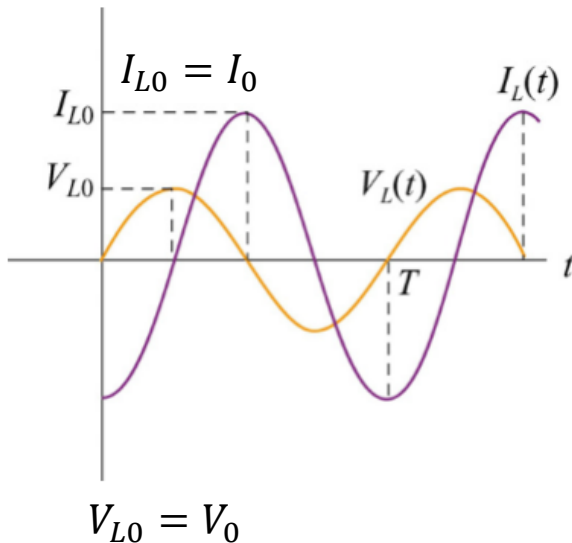

Current lags voltage by 90 degrees

Computing Methods Using RL Circuits under Frequency Response ...

- ▶ Z_X refers to the value of the electrical parameter of an inductor under measurement. R_{ref} is a resistor with a precise value of resistance.
- ▶ Hence, the inductance could be computed as follows:

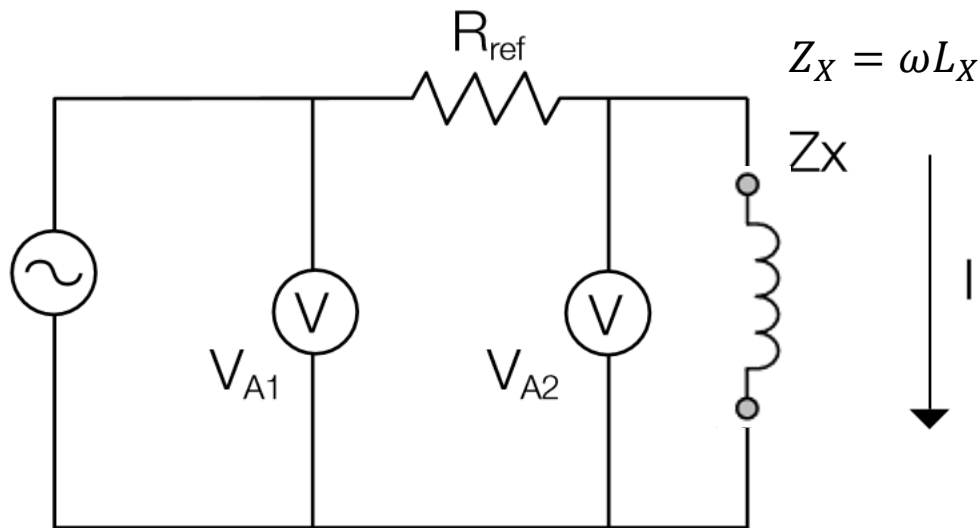

$$Z_X = \frac{V_{A2}}{I} = \frac{V_{A2}}{V_{A1} - V_{A2}} R_{ref}$$

$$L_X = \frac{Z_X}{\omega}$$

Example

- ▶ Voltage amplitude measured at A1 is: $V_{A1} = 1.832$ V. Voltage amplitude measured at A2 is $V_{A2} = 0.952$ V. Phase difference between voltage measured at A2 relative to A1 is $\theta = 56.03^\circ$. What is the amplitude of the difference between Voltage at A1 and Voltage at A2?

- ▶ Answer:

$$\vec{V}_{A2} = V_{A2} \cos(\theta) \vec{i} + V_{A2} \sin(\theta) \vec{j}$$

$$\vec{V}_{A1} = V_{A1} \vec{i}$$

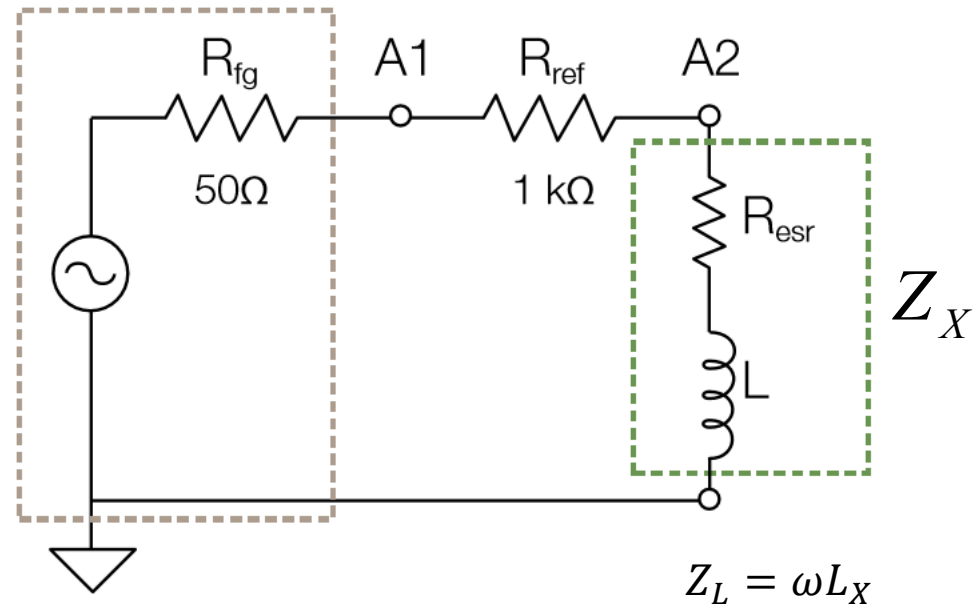

Answer:

$$\vec{V}_{A2} = V_{A2} \cos(\theta) \vec{i} + V_{A2} \sin(\theta) \vec{j}$$

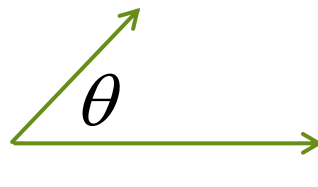

$$\vec{V}_{A1} = V_{A1} \vec{i}$$

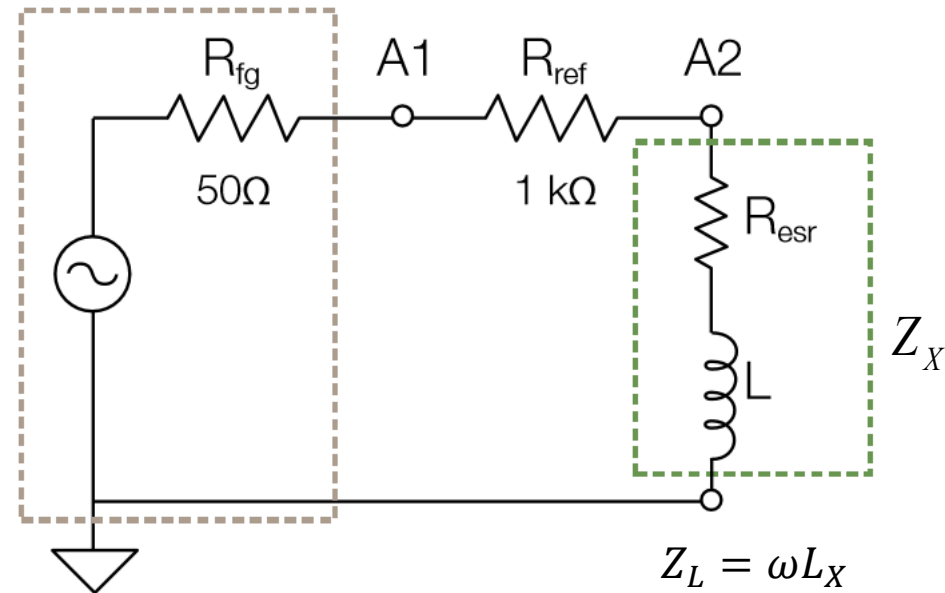

$$|\vec{V}_{A1} - \vec{V}_{A2}| = \sqrt{(V_{A1} - V_{A2} \cos(\theta))^2 + (0 - V_{A2} \sin(\theta))^2}$$

$$|\vec{V}_{A1} - \vec{V}_{A2}| = \sqrt{V_{A1}^2 - 2V_{A1}V_{A2} \cos(\theta) + V_{A2}^2}$$

$$|\vec{V}_{A1} - \vec{V}_{A2}| = \sqrt{1.832^2 - 2 \cdot 1.832 \cdot 0.952 \cos(56.03^\circ) + 0.952^2}$$

Example

- ▶ Voltage amplitude measured at A1 is: $V_{A1} = 1.832$ V. Voltage amplitude measured at A2 is $V_{A2} = 0.952$ V. Phase difference between voltage measured at A2 relative to A1 is $\theta = 56.03^\circ$. What is the resistance of the inductor if $R_{ref} = 1$ K Ohms?

- ▶ Answer:

$$Z_X = \frac{V_{A2}}{I} = \frac{V_{A2}}{V_{A1} - V_{A2}} R_{ref}$$

(to continue)

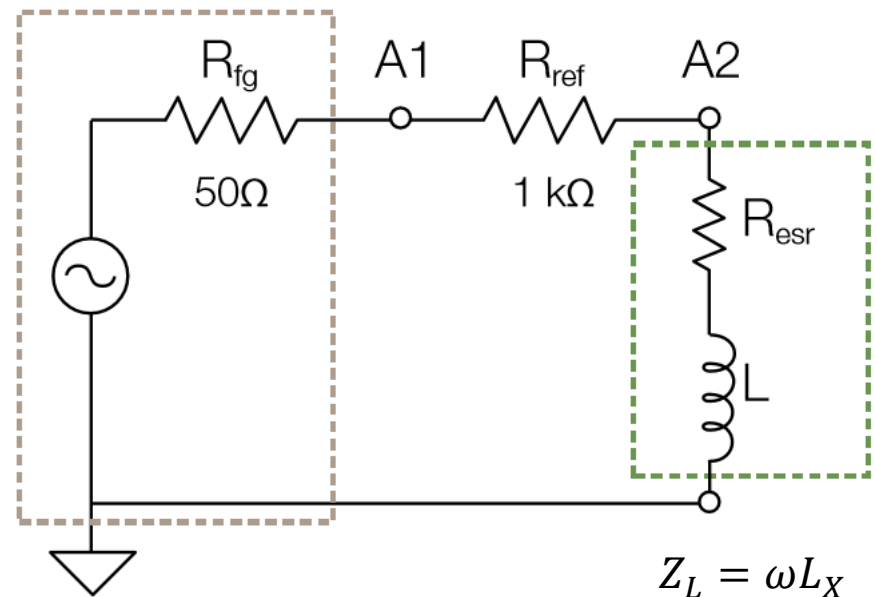

Answer

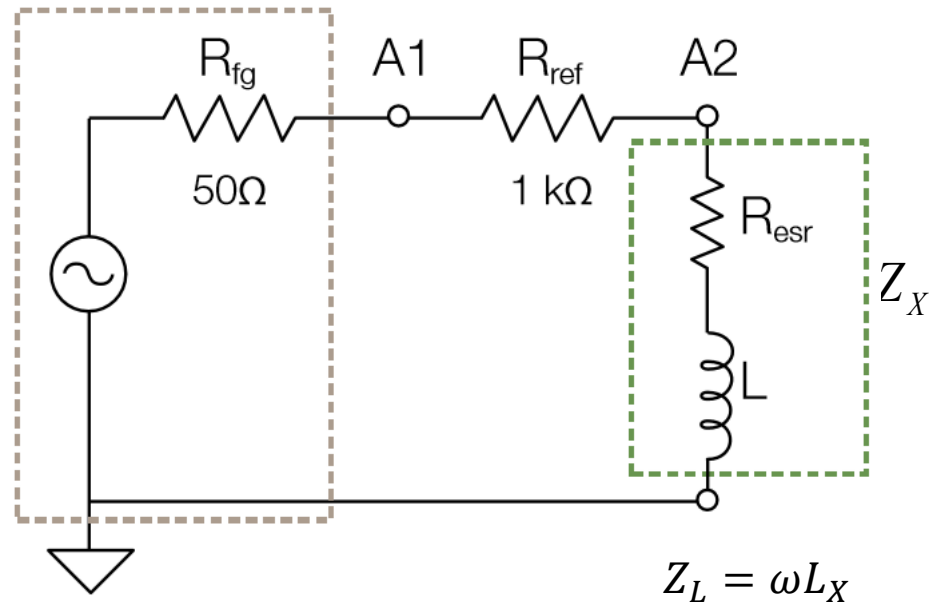

$$Z_X = \frac{V_{A2}}{I} = \frac{V_{A2}}{V_{A1} - V_{A2}} R_{ref}$$

$$Z_X = \frac{0.952 \cdot 1000}{\sqrt{1.832^2 - 2 \cdot 1.832 \cdot 0.952 \cos(56.03^\circ) + 0.952^2}}$$

$$Z_X = 625.895\ \Omega \quad \Rightarrow \quad L_X = \frac{Z_X}{\omega}$$

Computing Methods of Using RL Circuits under Transient Response ...

Idea of Calculating L

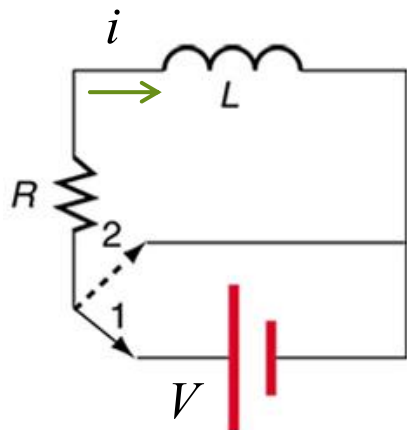

(a)

Switch to 1

$$V = iR + L \frac{di}{dt}$$

$$i = \frac{V}{R} (1 - e^{-tR/L})$$

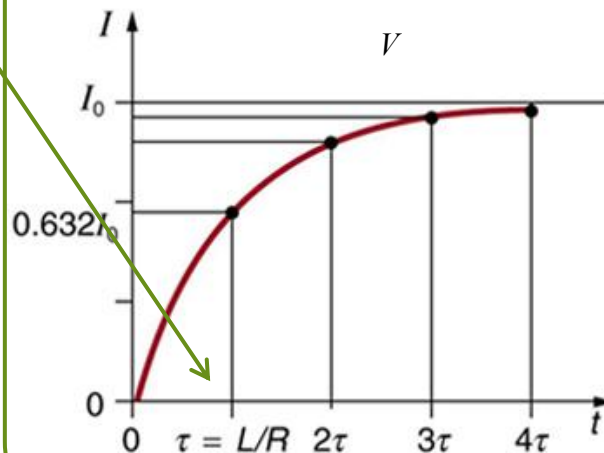

(b)

Switch to 2

$$iR + L \frac{di}{dt} = 0$$

$$i = \frac{V}{R} e^{-tR/L}$$

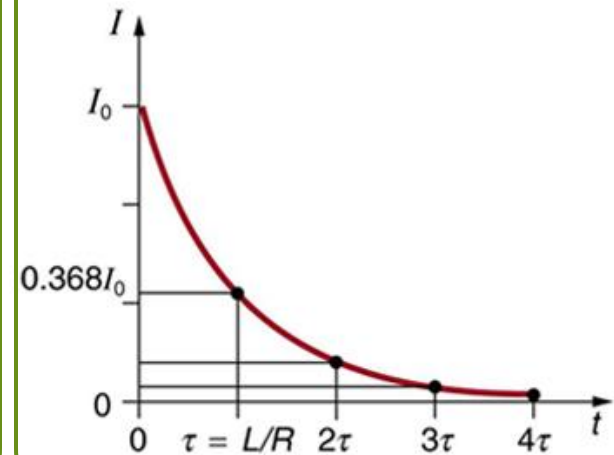

(c)

Computing Methods Using Bridge Circuits

- Four devices form a rectangular loop. A known power source is applied to one pair of diagonal points. The voltage output from another pair of diagonal points indicates the in-balance or out-of-balance of the bridge circuit.

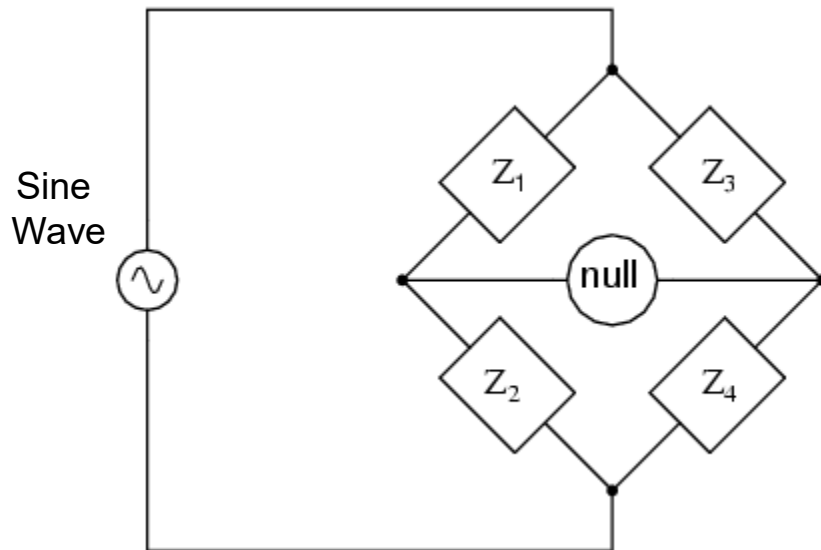

$$V_{null} = \frac{V_s}{Z_1 + Z_2} Z_2 - \frac{V_s}{Z_3 + Z_4} Z_4$$

$$0 = \frac{V_s}{Z_1 + Z_2} Z_2 - \frac{V_s}{Z_3 + Z_4} Z_4$$

$$\frac{Z_2}{Z_1 + Z_2} = \frac{Z_4}{Z_3 + Z_4}$$

Example

- ▶ If V_{null} of the circuit below is equal to zero, what is the equation of calculating L_x ?
- ▶ Answer:

$$Z_1 = R_x + j\omega L_x$$

$$Z_2 = R$$

$$Z_3 = R \qquad \frac{1}{Z_4} = \frac{1}{1/j\omega C_s} + \frac{1}{R_s}$$

$$Z_1 = R_x + j\omega L_x$$

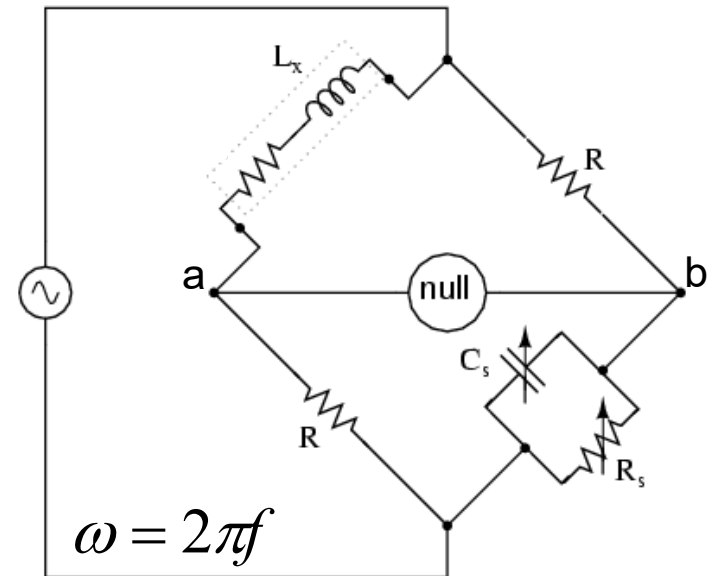

to continued ...

Continued ...

$$\frac{Z_2}{Z_1 + Z_2} = \frac{Z_4}{Z_3 + Z_4}$$

$$\frac{R}{Z_1 + R} = \frac{Z_4}{R + Z_4} \Rightarrow Z_1 = \frac{R^2}{Z_4}$$

$$\frac{1}{Z_4} = \frac{1}{1/j\omega C_s} + \frac{1}{R_s} \rightarrow \oplus \rightarrow Z_1 = \frac{(1 + j\omega R_s C_s)}{R_s} R^2 \Rightarrow L_X = C_s R^2$$

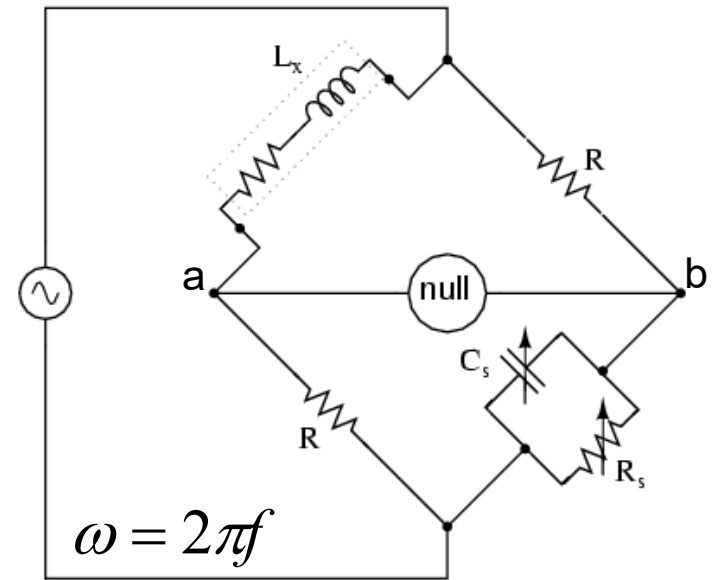

$$Z_1 = R_x + j\omega L_x$$

This is a vector

Outline

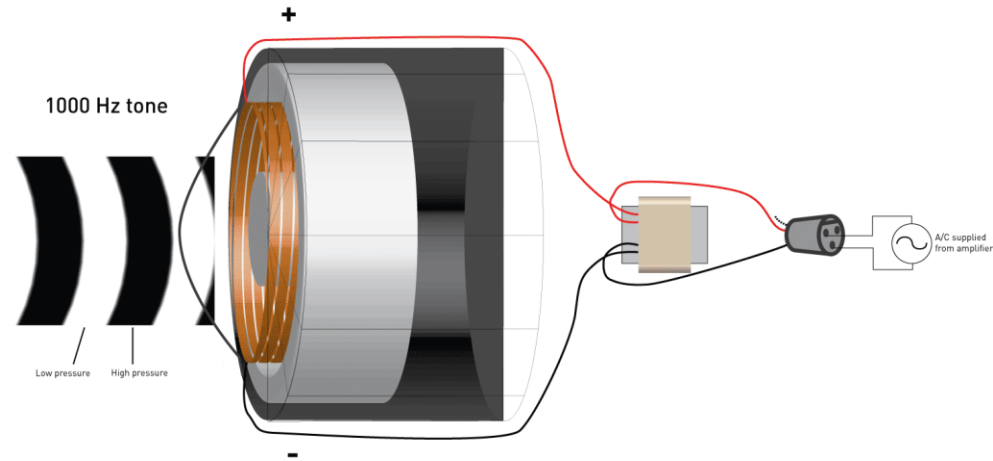

► Understanding of Inductance

► Computation of Inductance

► Measurement of Inductance

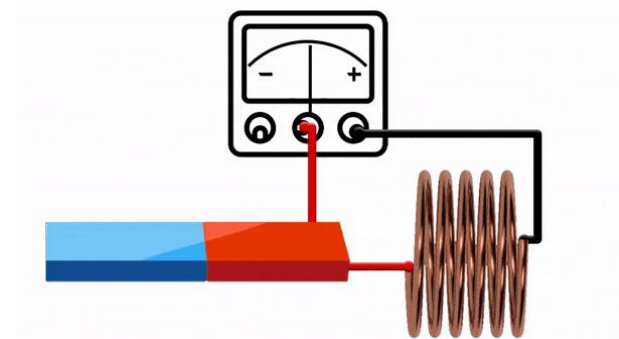

Applications

- ▶ Transformers
- ▶ Electro-magnets
- ▶ Sensing Elements (e.g. acoustic sensors)

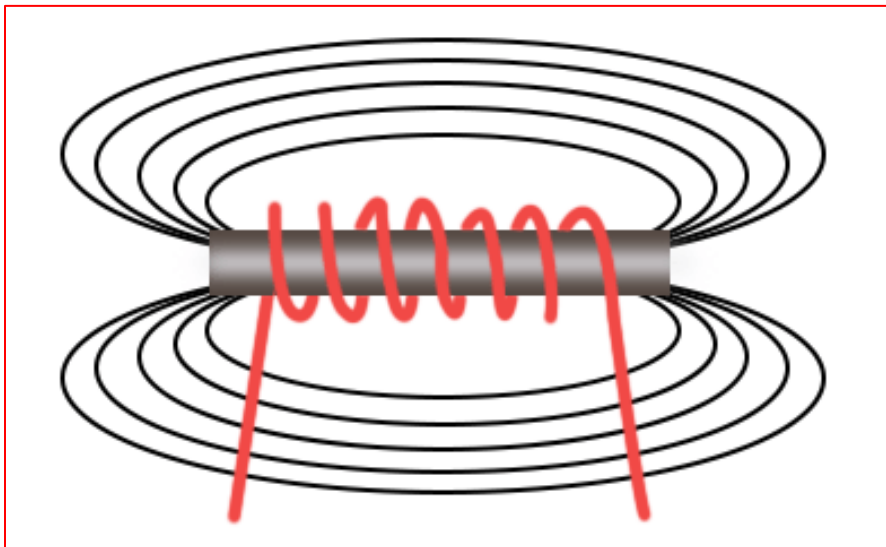
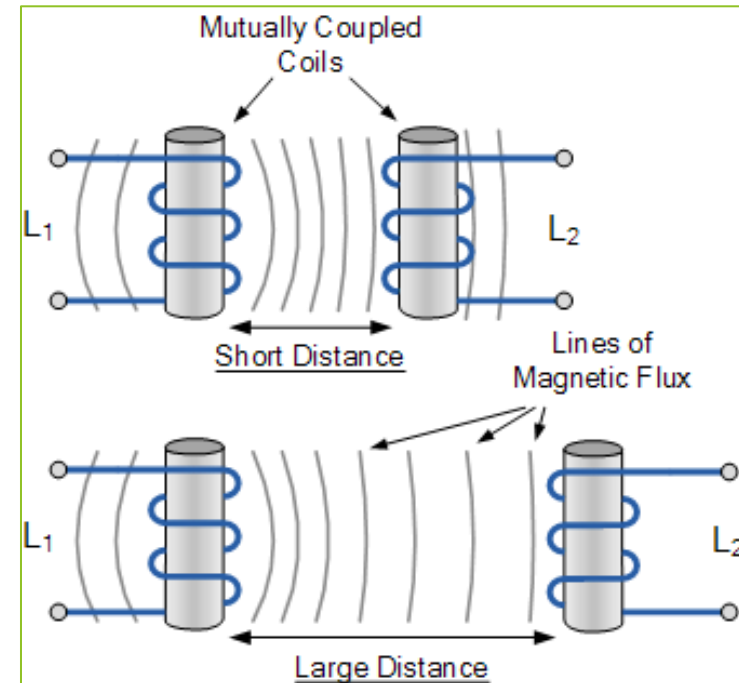

1. Flow of charges creates magnetic field.
2. Change of magnetic field creates flow of charges.

Current

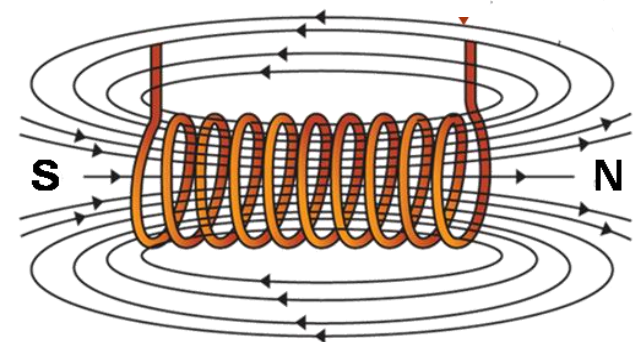

Example of Applications

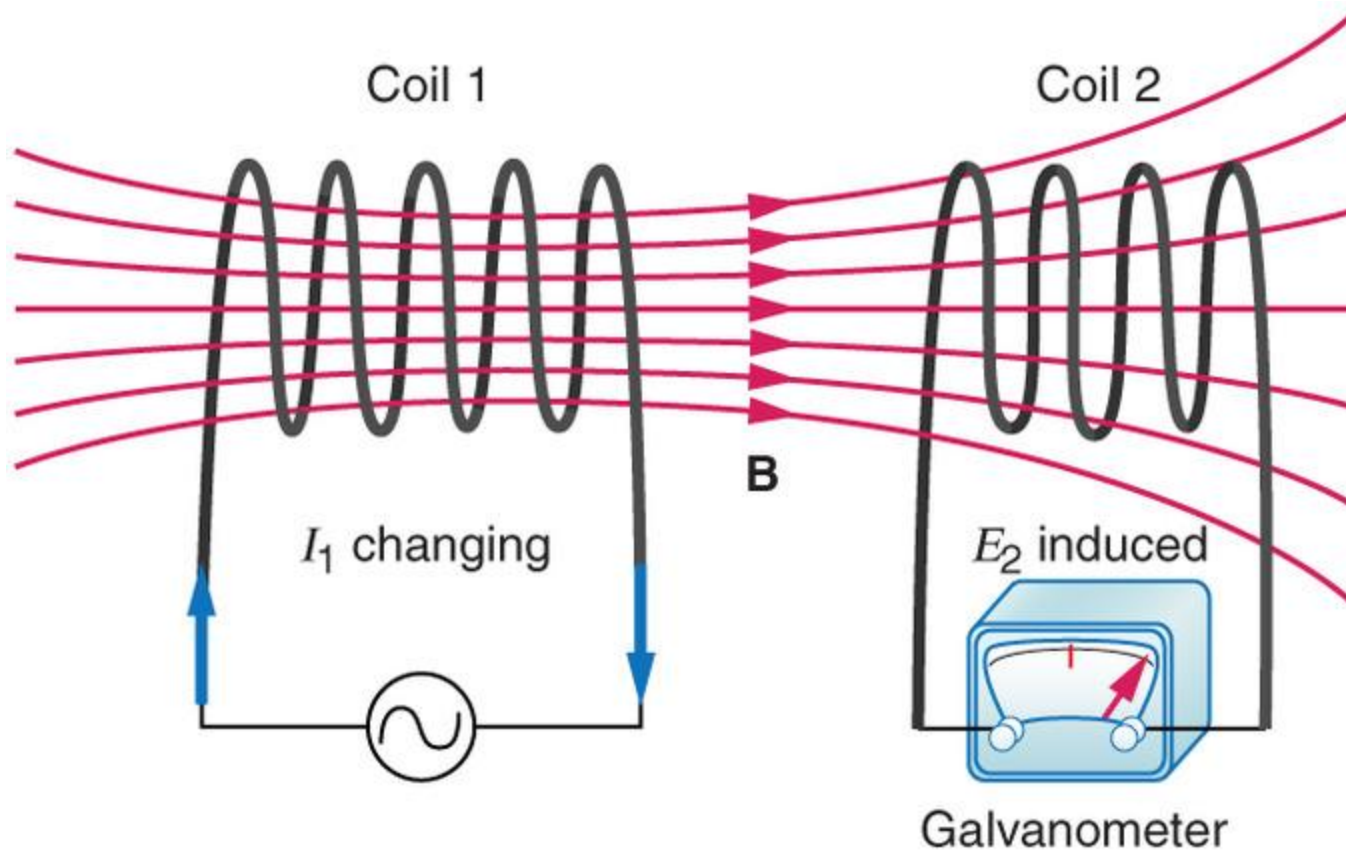

Example of Applications

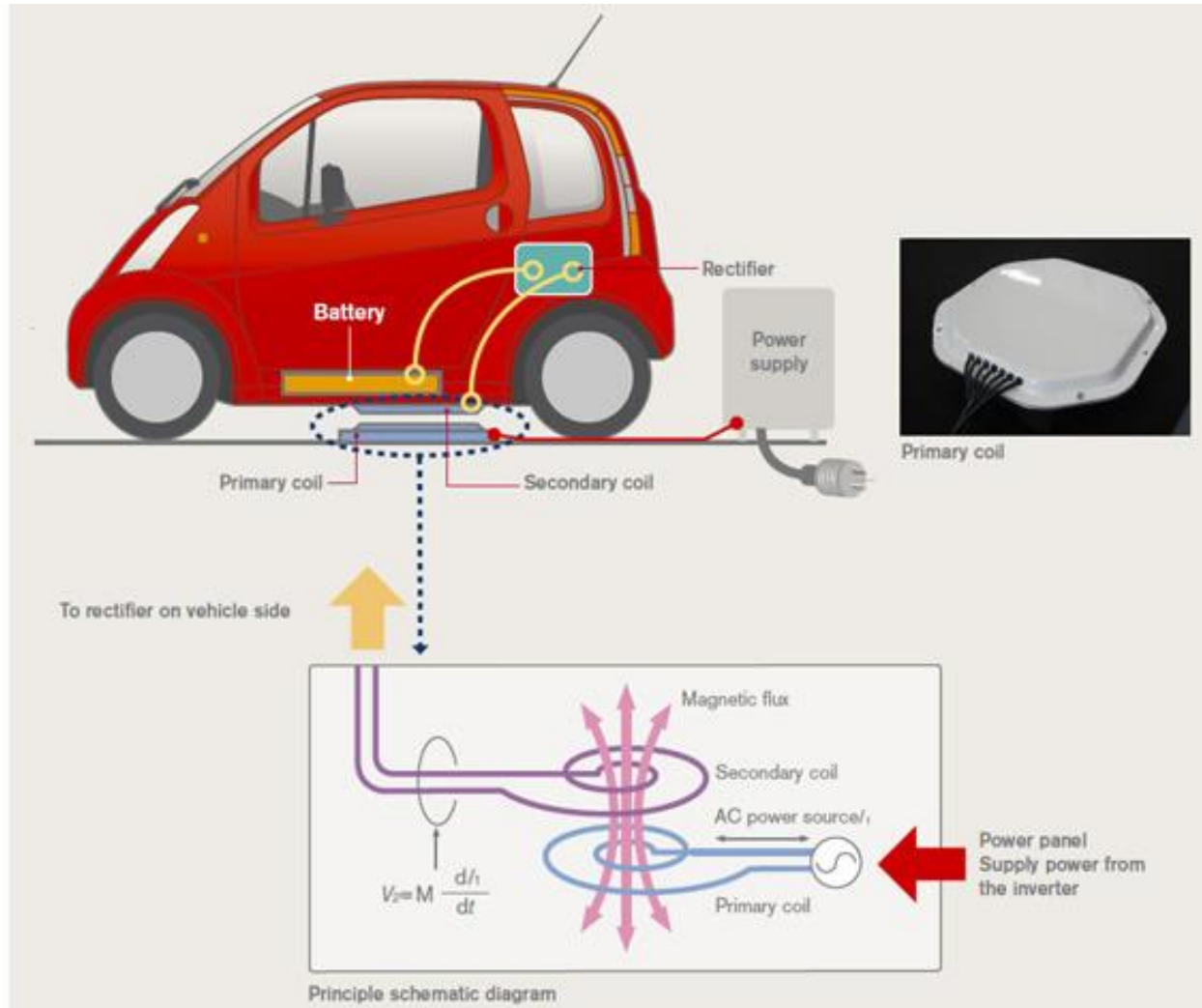

Example of Applications

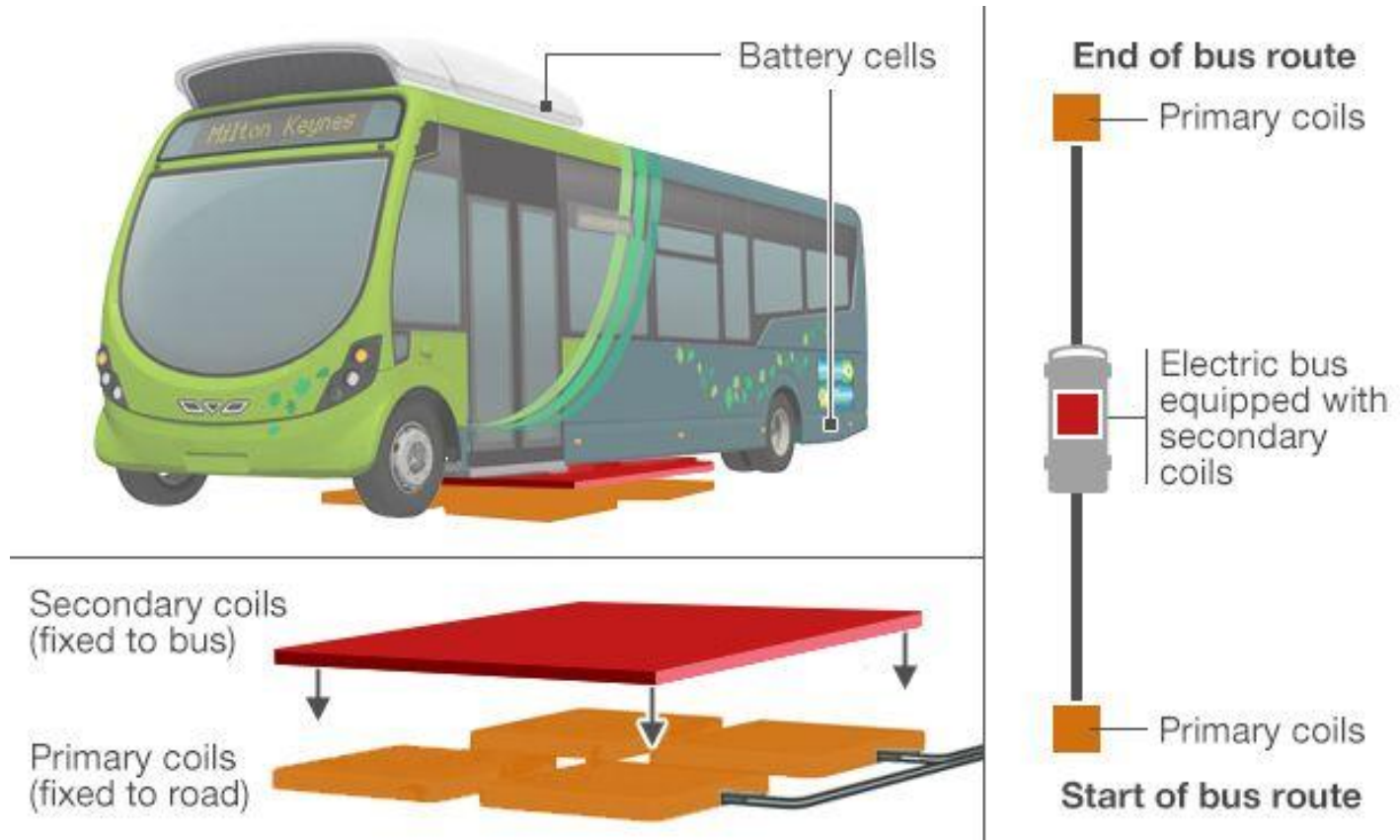

Example of Applications



Example of Applications

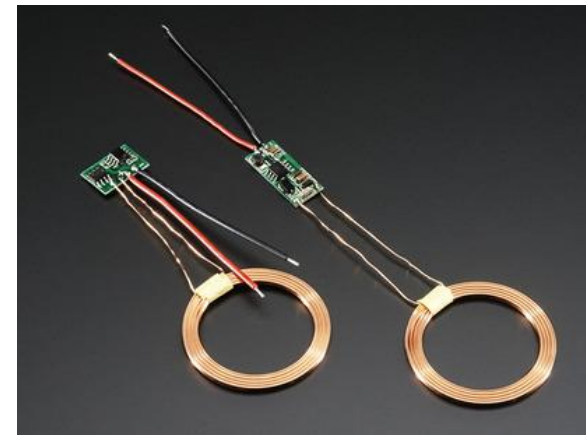

Example of Applications

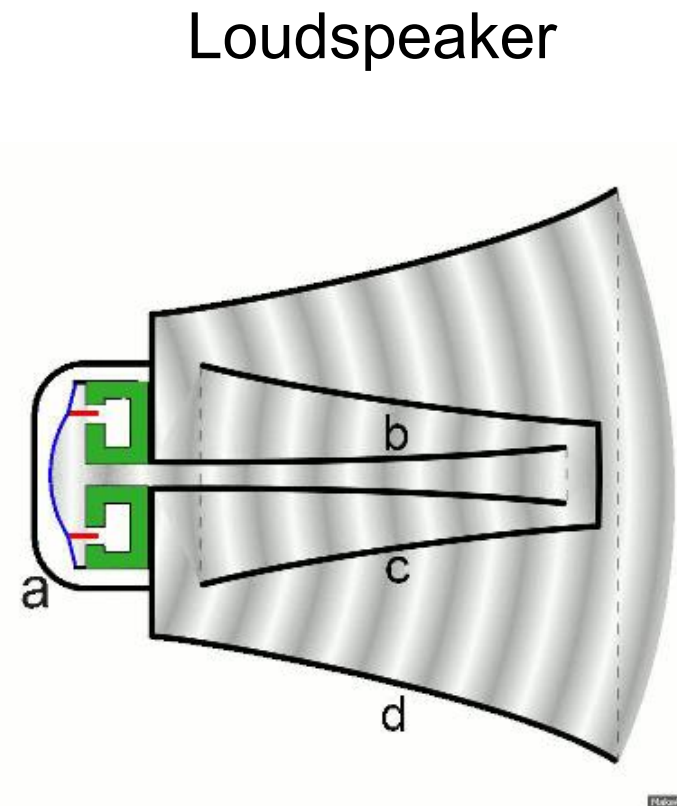
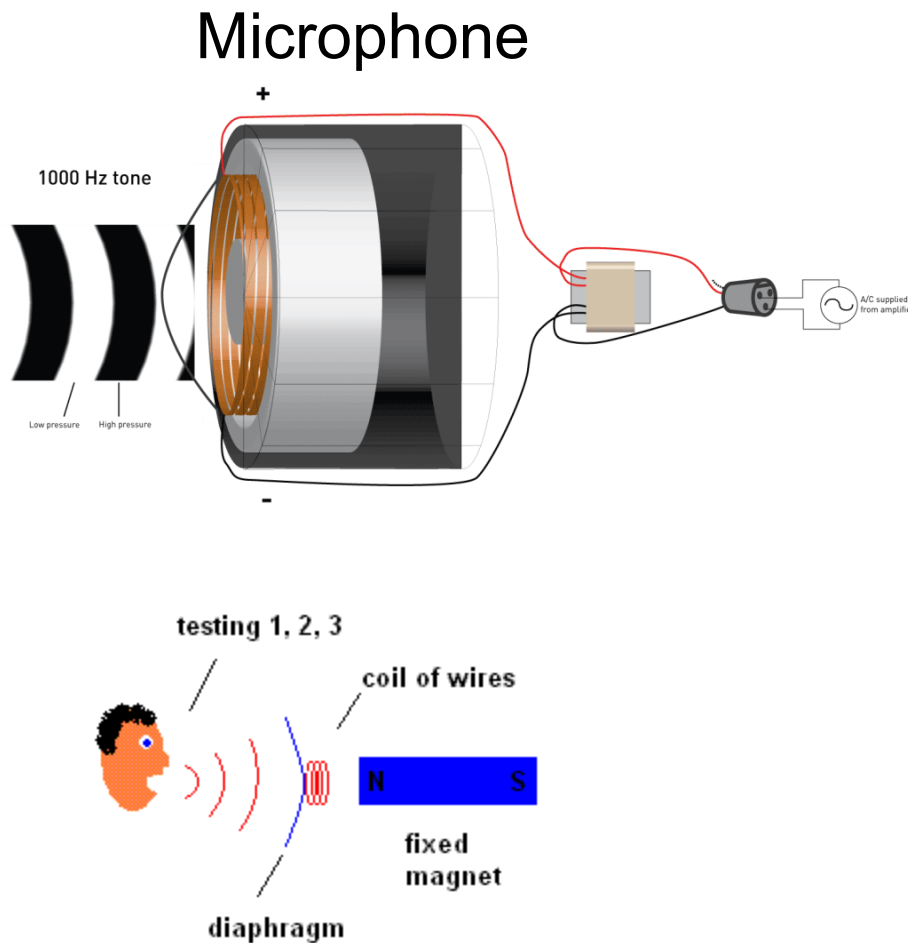

Principles of Measuring Inductance

- ▶ Electric voltage can be automatically measured.
- ▶ Electric current can be automatically measured.
- ▶ Electric inductance could be related to voltage or current.
- ▶ Hence, electric inductance can also be automatically measured.

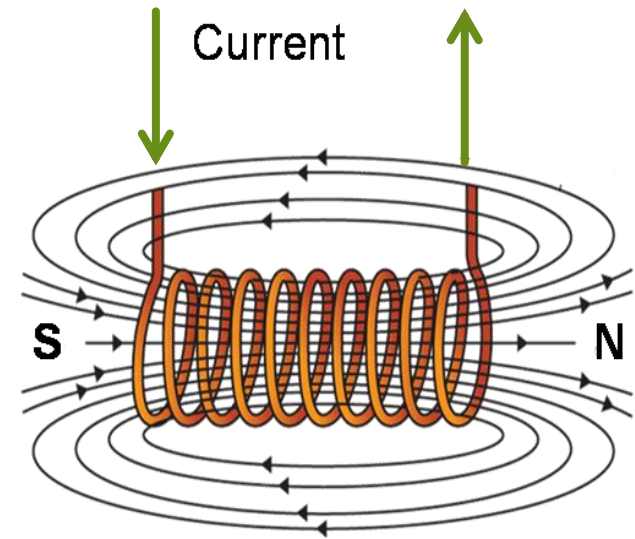

How to design digital measurement and sensing systems for inductance?

- ▶ Inductance is converted to voltage which is measured by digital voltmeter (e.g. microcontrollers).

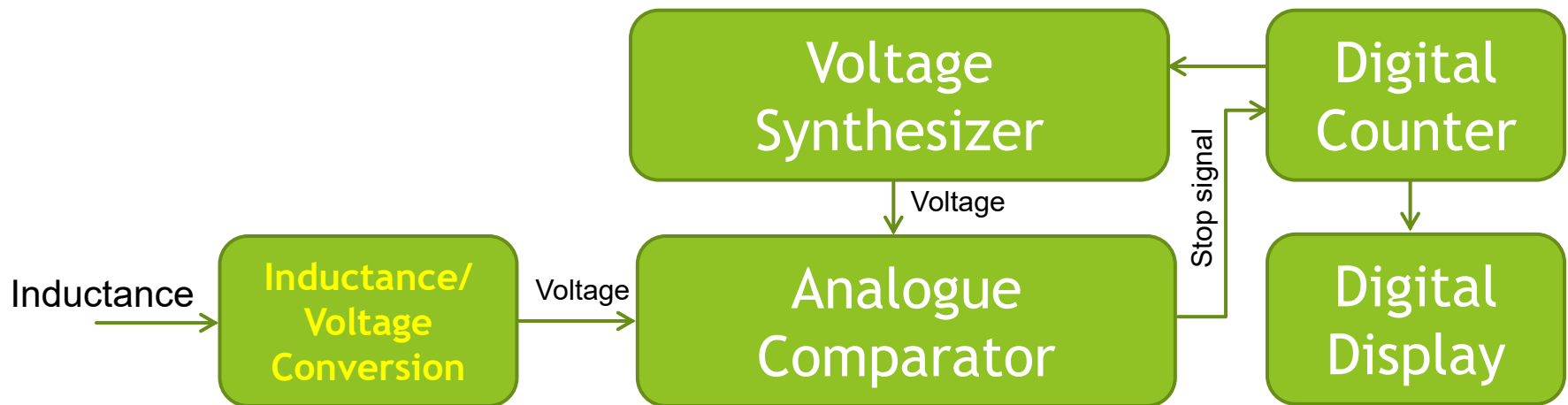

All microcontrollers are programmable digital sensors of voltage!

How to convert inductance into AC voltage?

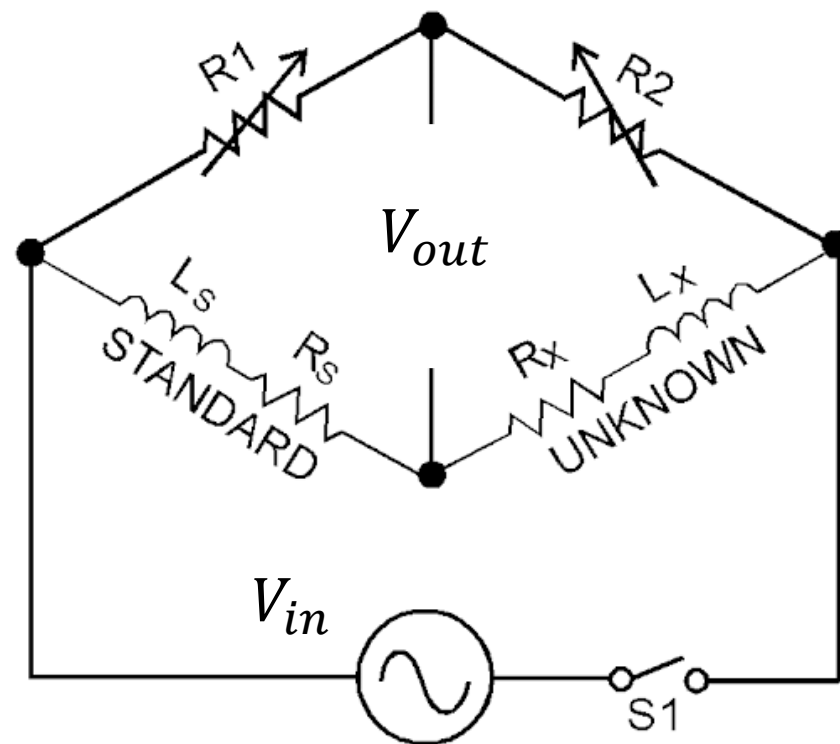
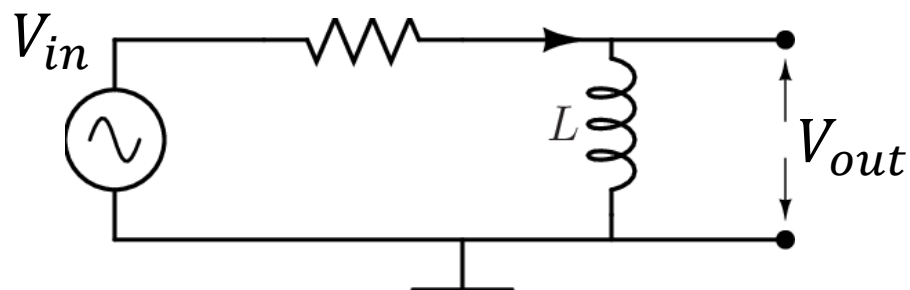
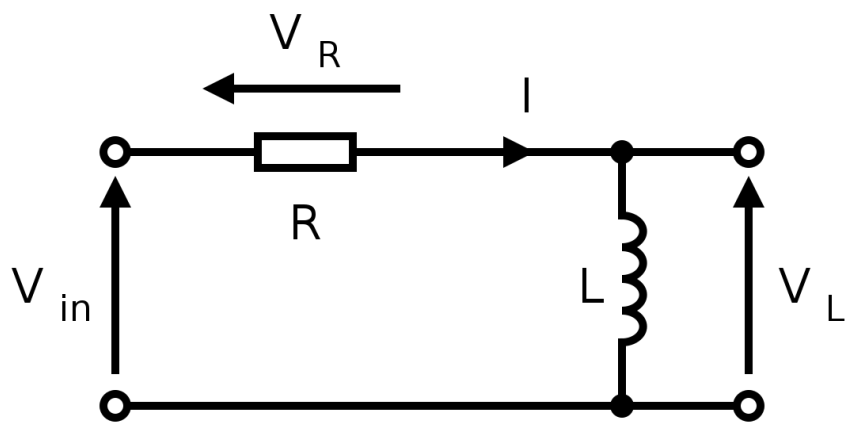

How to convert AC voltages into DC voltages?

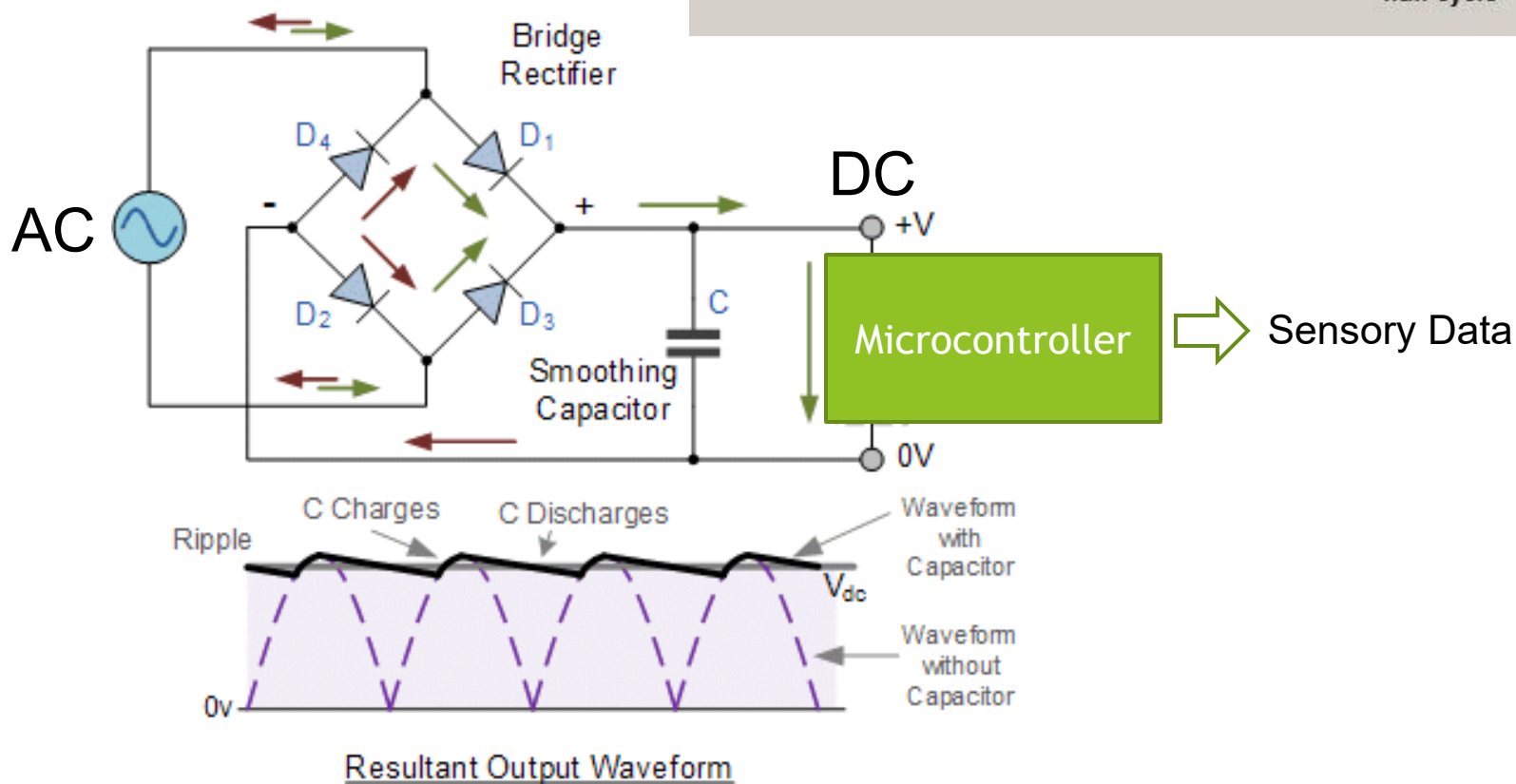
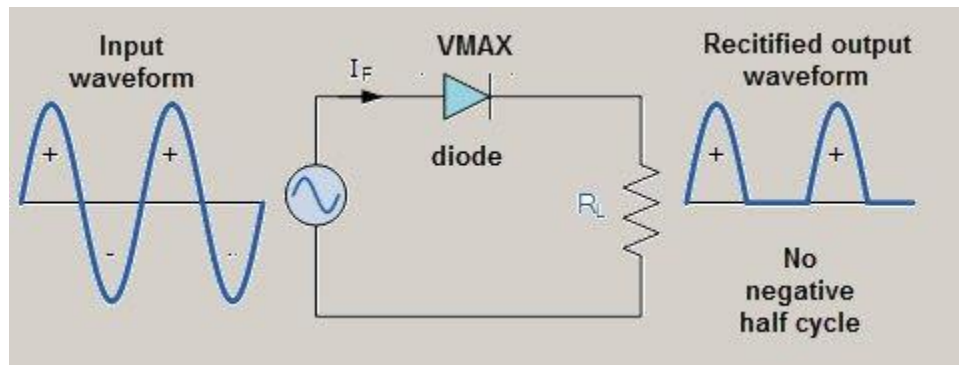

Example of
Converting
Inductance to AC
Voltage Which Is
Further
Converted Into
DC Voltage

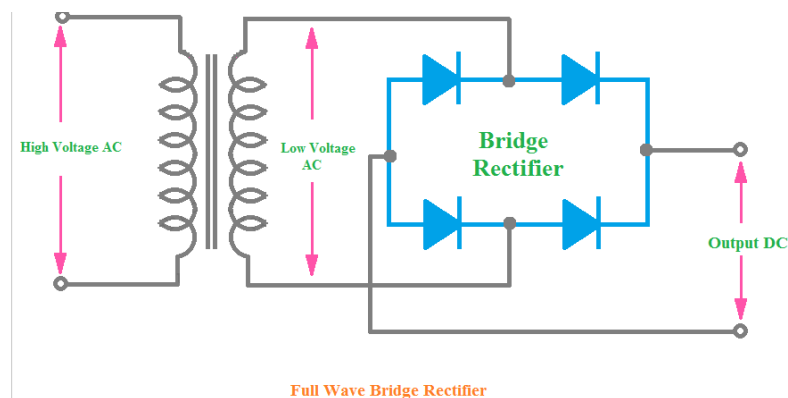
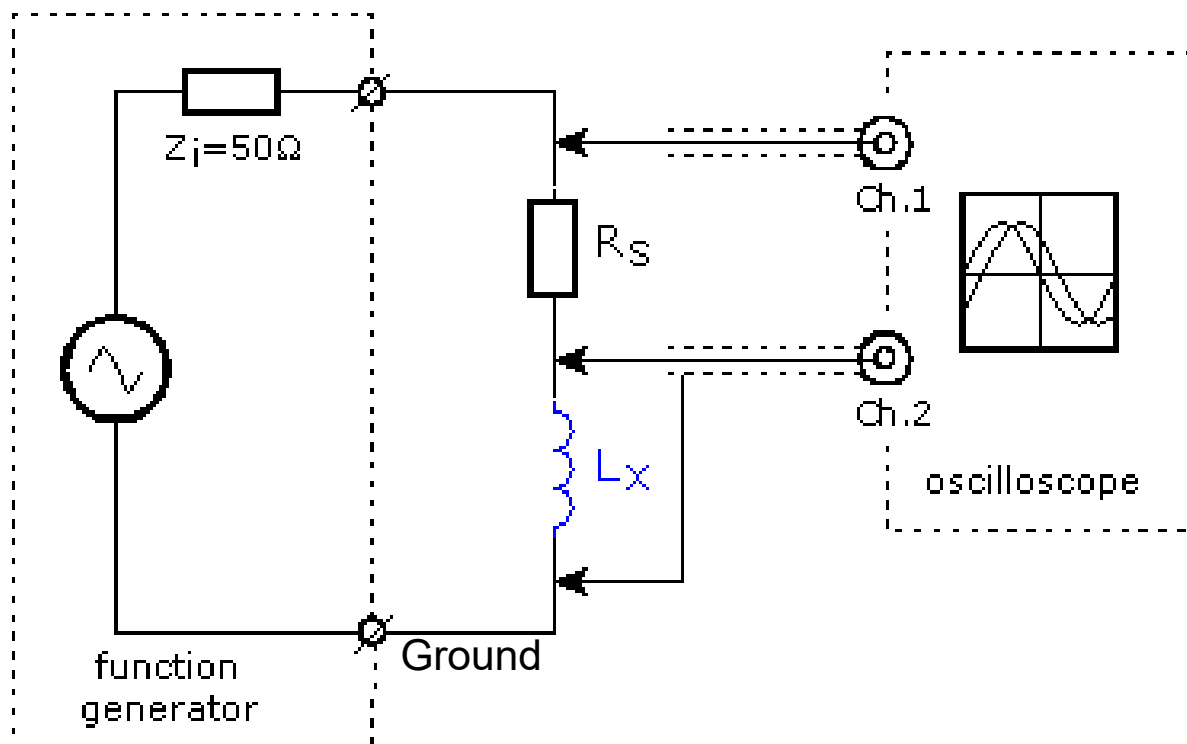

Remember to Do Calibration

- ▶ Curve fitting for calibration:
 - ▶ Y_i is produced by X_i
 - ▶ Z_i is computed from Y_i
 - ▶ Z_i must be equal to X_i

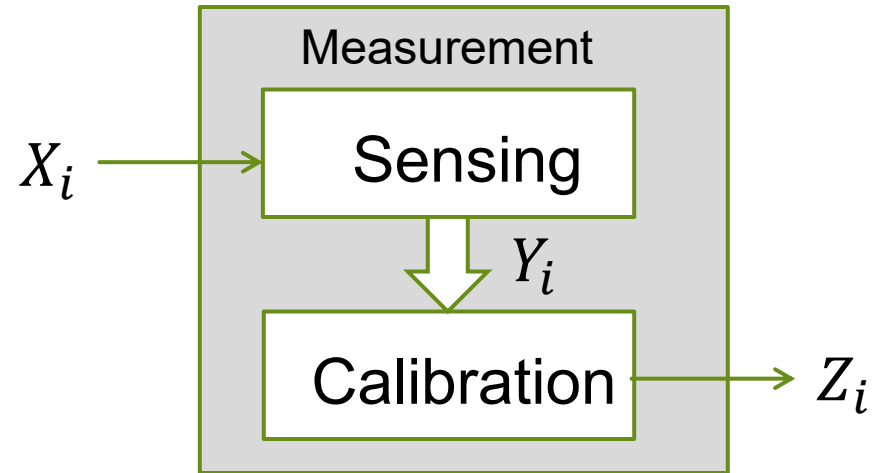

Calibrated Values Z_i

Measured Values Y_i

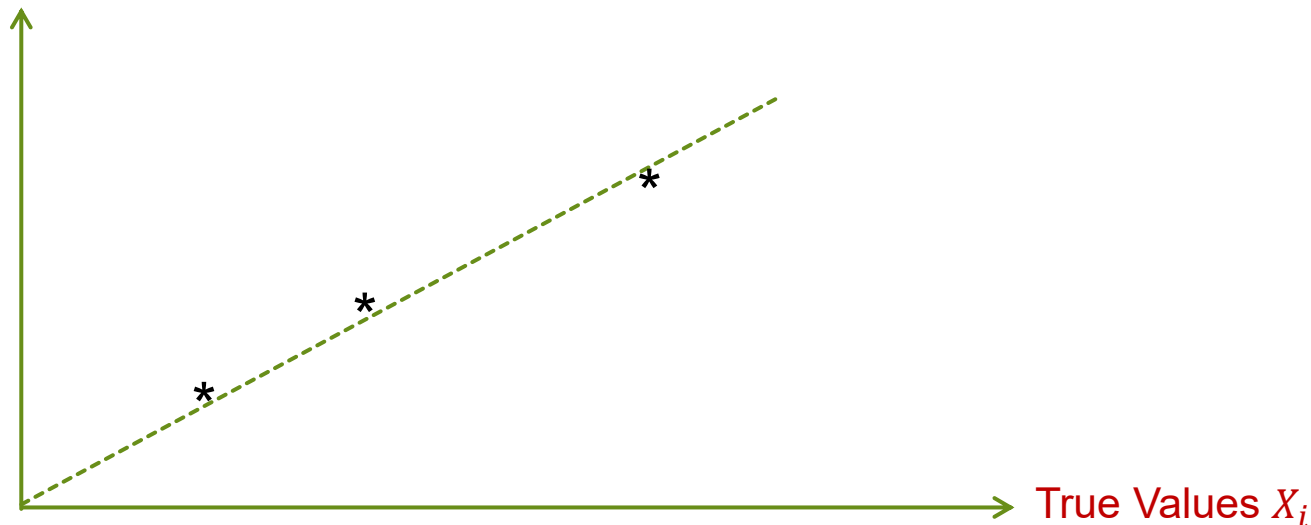

Remember to Do Error Analysis

- ▶ Systematic error = mean value - true value
- ▶ Repeatability error = value with maximum error - mean value
- ▶ Accuracy = value with minimum error - mean value
- ▶ Hysteresis error = |measured value in increasing - measured value in decreasing|

For each true value, we can do error analysis

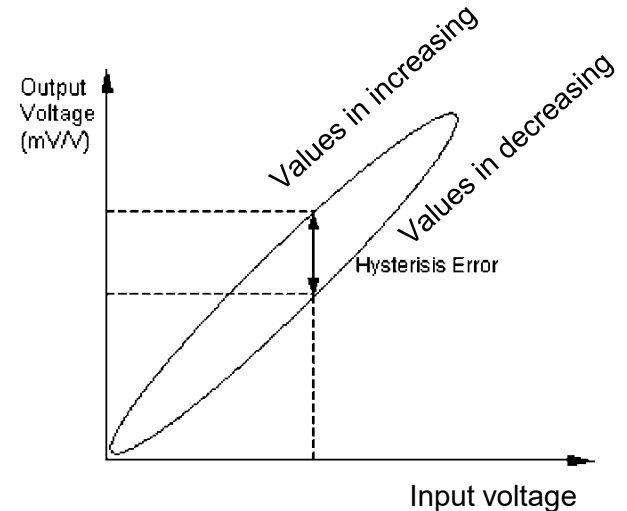
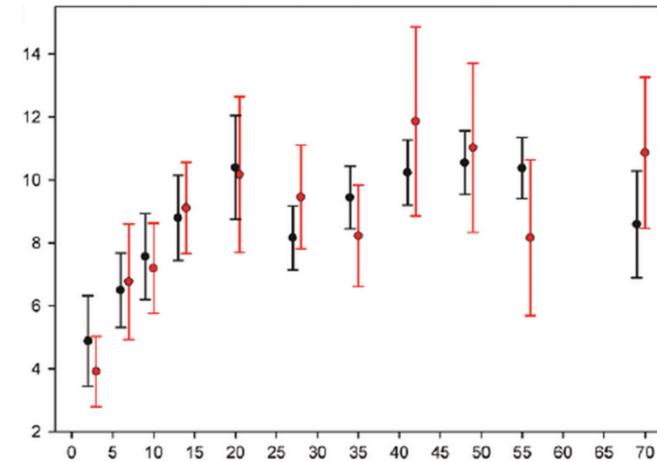

Summary

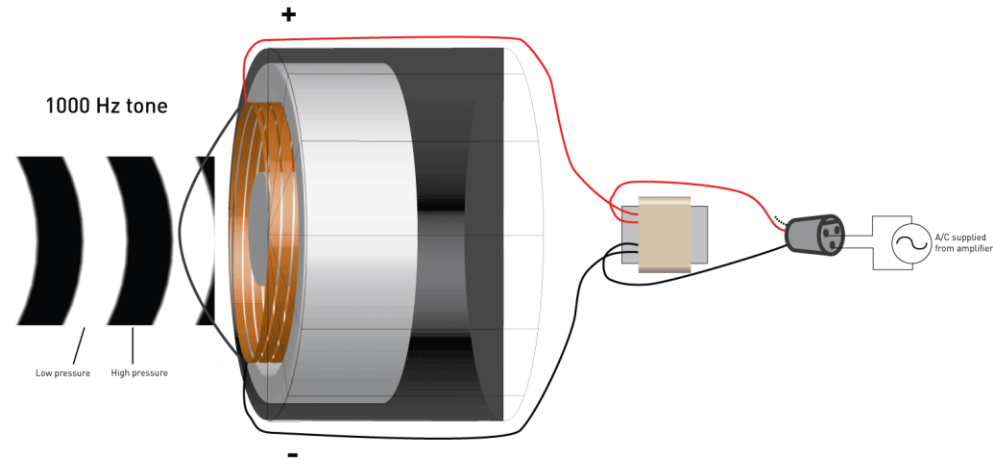

► Understanding of Inductance

► Computation of Inductance

► Measurement of Inductance

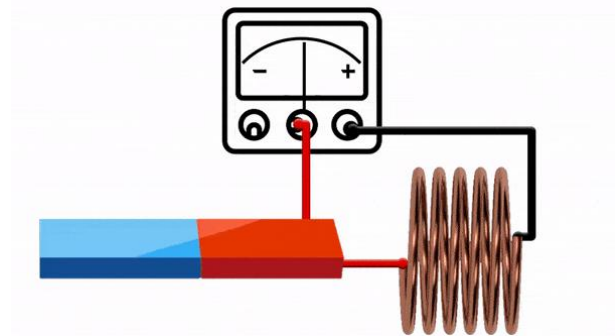

Summary of Module 2

- ▶ Lecture 1:
 - ▶ Measurement of Voltage
- ▶ Lecture 2:
 - ▶ Measurement of Current
- ▶ Lecture 3:
 - ▶ Measurement of Resistance
- ▶ Lecture 4:
 - ▶ Measurement of Capacitance
- ▶ Lecture 5:
 - ▶ Measurement of Inductance

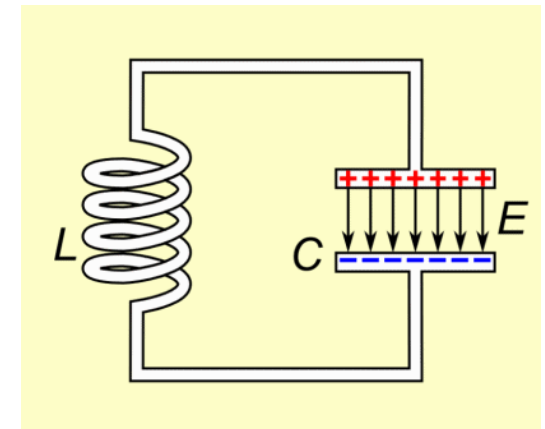
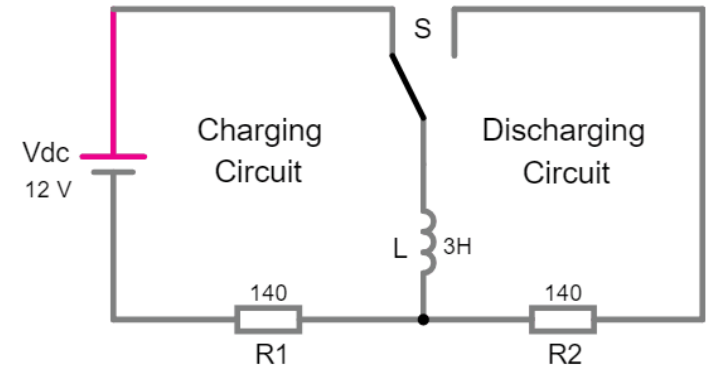
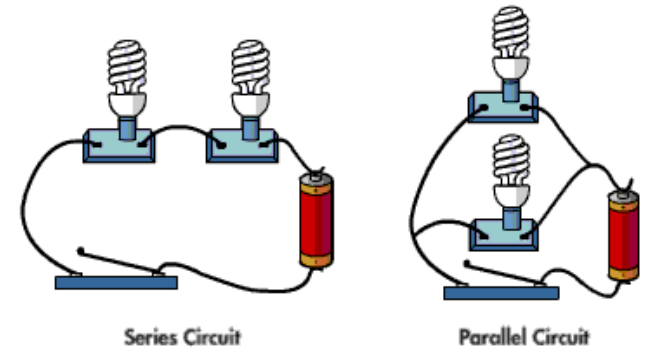



NANYANG
TECHNOLOGICAL
UNIVERSITY

School of Mechanical & Aerospace Engineering

Design, Machine, Control, Intelligence

“Ask not what your country can do for you – ask what you can do for your country,” - John F. Kennedy

“Do not think that you are needy – think that you are needed in the world”, - Manis Friedman

“Study will make you knowledgeable, resourceful, and hence more needed”, - Xie Ming

Thank You for Listening!